

# KARGO MASTER®

**WE PUT EVERYTHING WITHIN REACH.**

---

## Installation Guide Pro II Service Body Rack

---

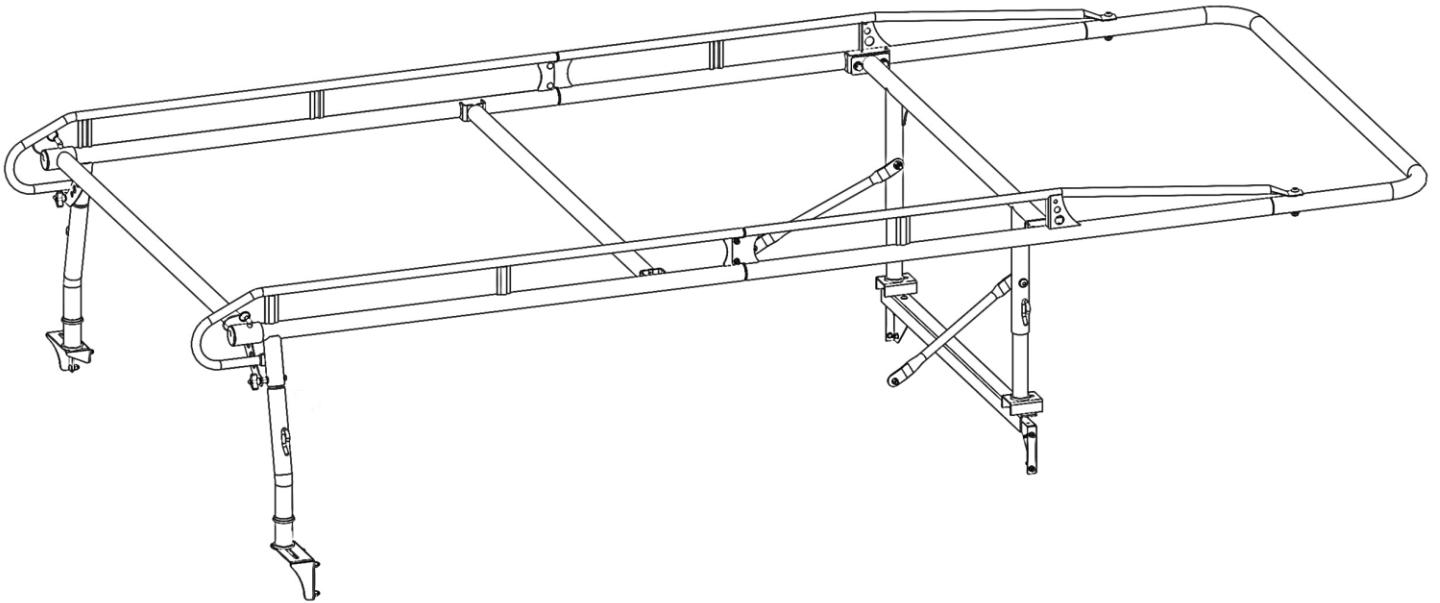

---

Kargo Master  
Rancho Cordova, CA 95742  
800-343-7486  
CustomerService@KargoMaster.com

---

**\* PLEASE READ ALL INSTRUCTIONS AND WARNINGS PRIOR TO ASSEMBLING, INSTALLING, AND USING THIS PRODUCT. \***

---

**WARNING**



Always check for wires, fuel tanks and lines, brake lines and other important vehicle functionality items prior to drilling and installing all products.



Too much weight will greatly reduce the stability of your vehicle. Kargo Master makes no representation or warranty as to the amount of weight your vehicle can safely carry. For guidance, we recommend that you consult the vehicle manufacturer. At no time should the weight of the vehicle, rack, driver, passengers and cargo loaded on a Kargo Master rack exceed either the Gross Vehicle Weight Ratio (GVWR) or the Gross Axle Weight Ratio (GAWR) as specified by the vehicle manufacturer.



Do not use your rack with the rear cross bar removed. Removal of rear crossbar will affect structural integrity of the rack.



Secure all payloads properly for safe transportation.



A large area is required to assemble rack. Be sure to keep area clear of trip and fall hazards.

---

**Before You Begin**

1. Read all instructions carefully, and follow each step in proper sequence, for ease and speed in assembling your Kargo Master rack.
2. Be sure the side channel kit is correct.
  - a. Side Channel kit 78000 fits an 8ft body mounted on a standard cab chassis.
  - b. Side Channel kit 78010 fits an 8ft body mounted on an extended cab chassis.
  - c. Side Channel kit 79000 fits a 9ft body mounted on a standard cab chassis.
  - d. Side Channel kit 79010 fits a 9ft body on an extended cab chassis and 11ft body mounted on a standard cab chassis.
3. The “bulkhead” is the panel at the front of the service body. Measure the distance from the top of the bulkhead to the top of the truck’s cab. This distance should be in the range of 15” to 22”.

4. Standard mounting is on the rear panel. Check to ensure the rear panel of the service body is free of taillights or other obstructions (Inside or out) in the area where the rear legs of the rack bolt to the body. Consult sketch below.
- There must be open unobstructed space at least 1-3/4" above taillight and below flip top box lid.
  - There must be open unobstructed space at least 1-1/4" to the left or right of taillight.
  - The distance between the crown of the roof plus 2-1/2" to the top of the mount bracket must be no greater than 24-1/2".
  - The service body foot must be mounted as close as possible to the vertical exterior corner of the rear body panel. If mounting to the vertical exterior corner of the rear body panel is not possible, the right and left service body rear feet can be switched and the feet can be mounted as close as possible to the vertical interior corner of the rear body panel.

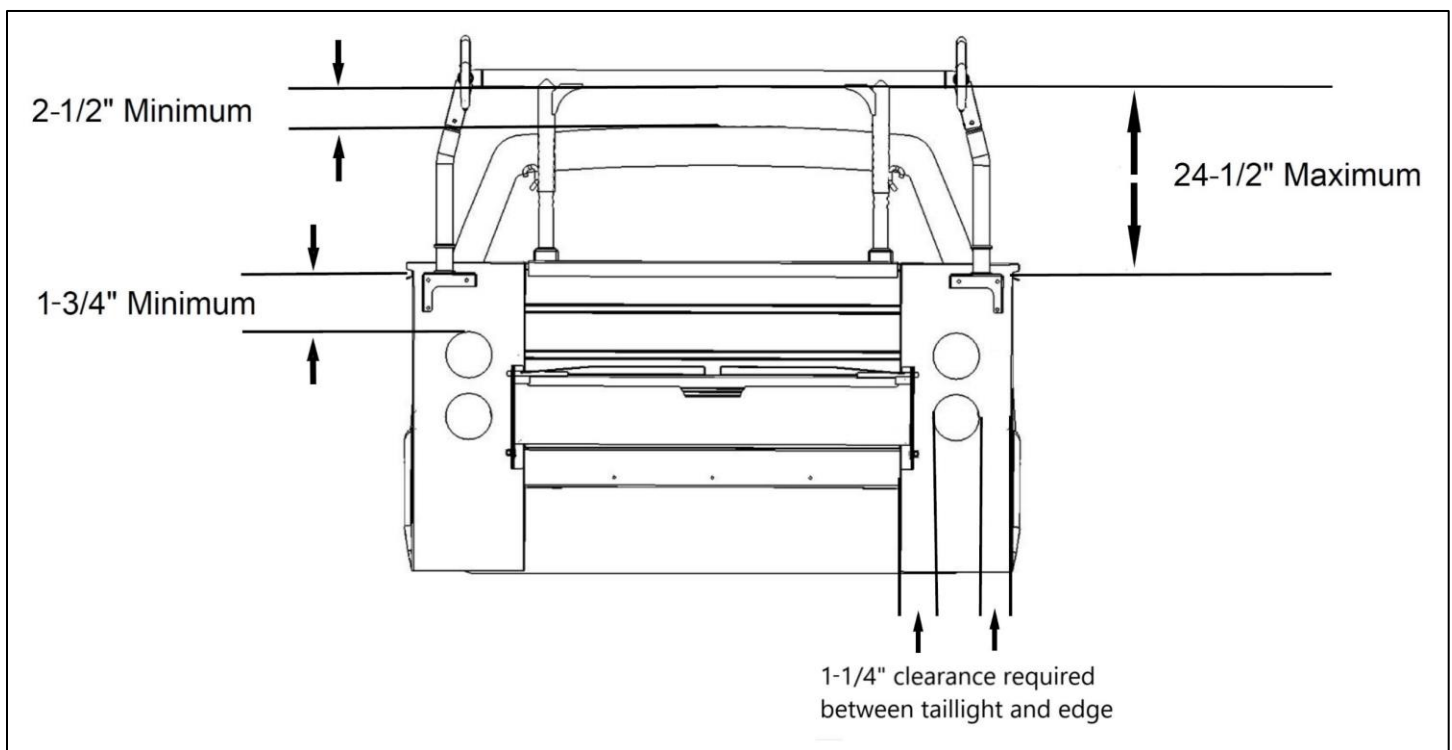

**Table of Contents**

Tools Needed..... 3

Parts List ..... 4

Assembly Hardware Kit ..... 6

Sealant Application..... 9

Step 1 – Join Side Channels ..... 9

Step 2 – Attach Front Tube..... 10

Step 3 – Attach Center Crossbar ..... 10

Step 4 – Attach Front Legs..... 10

Step 5 – Attach Rear Legs..... 11

Step 6 – Install Foot to Rack..... 12

Step 7 – Attach Rear Crossbar ..... 13

Step 8 – Front Leg Angle Mount Installation..... 13

Step 9 – Bulkhead Bracing Installation..... 14

Step 10 – Rear Foot to Service Body Installation ..... 15

Step 11 – Support Arm Installation ..... 16





Step 12 – Rack Installation ..... 17

**Tools Needed**



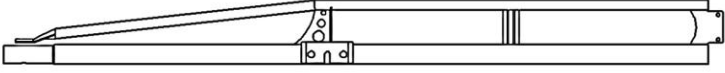
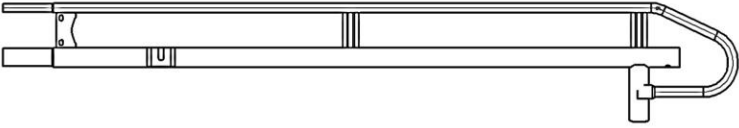
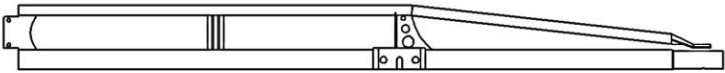
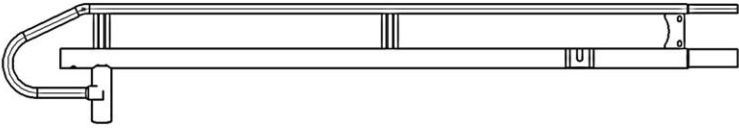

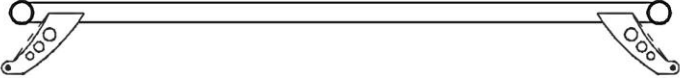
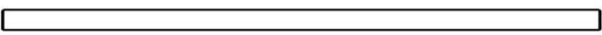
9/16", 3/4" Box Wrenches	1/2", 9/16", 3/4" Sockets and Wrench
7/32", 5/16"* Allen Wrenches	Drill
11/32, 13/32" Drill Bits	Mallet or Dead Blow Hammer
Center Punch	Torque Wrench

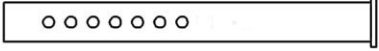
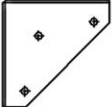
\* Included.

**Parts List**

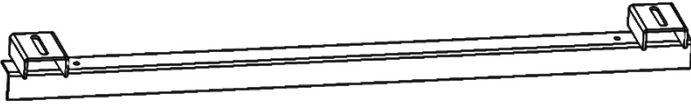
ITEM NO.	PART	PART NUMBER	DESCRIPTION	QTY.
1		78000 / 100636 78010 / 100635 79000 / 100687 79010 / 13-00822	SIDE CHANNEL, FRONT PS RH	1
2		78000 / 100638 78010 / 100630 79000 / 100630 79010 / 13-00819	SIDE CHANNEL, REAR PS RH	1
3		78000 / 100637 78010 / 100634 79000 / 100688 79010 / 13-00821	SIDE CHANNEL, FRONT DS LH	1
4		78000 / 100639 78010 / 100631 79000 / 100631 79010 / 13-00820	SIDE CHANNEL REAR DS LH	1
5		11-00004	FRONT TUBE FS	1
6		13-00826	REAR CROSS BAR FS	1
7		13-00028	CENTER CROSS BAR	1
8		13-00674	FRONT SERVICE BODY LEG ASSY	1
9		13-00659	SERVICE BODY TELESCOPING LEG	2
10		70020-10-010	CORNER SUPPORT	2

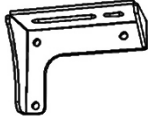
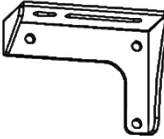
**Parts List (Continued)**





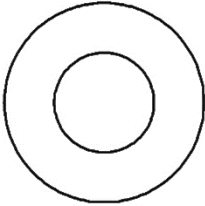
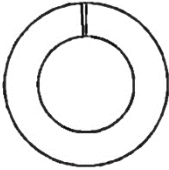
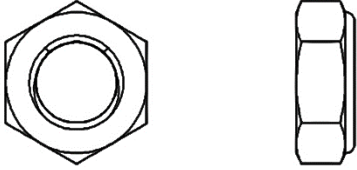
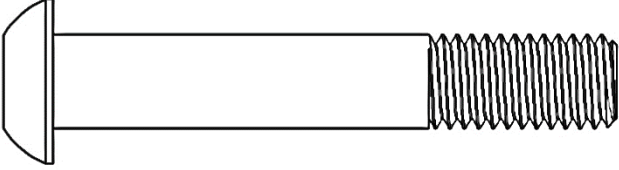
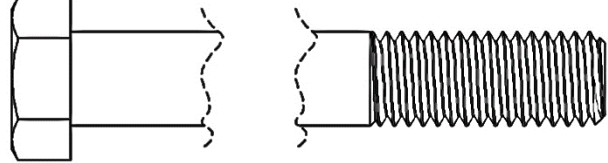
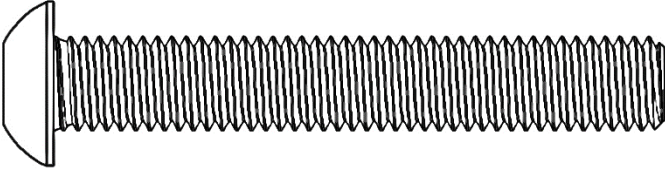
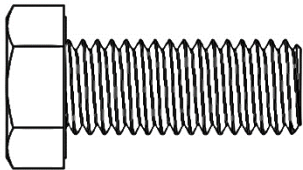
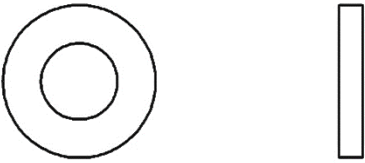
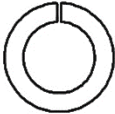

ITEM NO.	PART	PART NUMBER	DESCRIPTION	QTY.
11		13-00671	FRONT LEG ANGLE MOUNT	1
12		13-00839	REAR LEG	2
13		70020-10-003	SERVICE BODY FOOT, REAR LH	1
14		70020-10-004	SERVICE BODY FOOT, REAR RH	1
15		70020-16	3-1/2' LEG EXTENSION, 2" OD	2
16		11-00757	SERVICE BODY SUPPORT ARM	2
17		18-00260	SERVICE BODY BOLT KIT	1

**Assembly Hardware Kit**

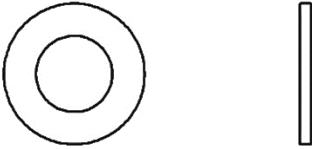
ITEM	HARDWARE TO SCALE	PART NUMBER	DESCRIPTION	QTY.
1		11541086	1/2" WASHER	22
2		1133626	1/2" SPLIT LOCK WASHER	12
3		37695	1/2"-13 THIN LOCKING JAM NUT	8
4		42KD91	1/2"-13 X 3" BUTTON HEAD CAP SCREW	4
5		11241240	1/2"-13 X 4-1/2" HEX HEAD BOLT	2
6			1/2"-13 x 3-1/4" BUTTON HEAD SCREW	2
7		11241379	1/2"-13 X 1-1/4" HEX HEAD BOLT	12
8		11101304	3/8" OVERSIZED FLAT WASHER	4
9		0123496	3/8" SPLIT LOCK WASHER	2

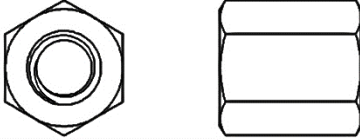
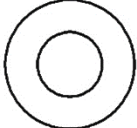

**Assembly Hardware Kit (Continued)**

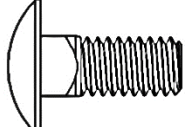
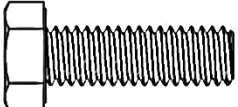
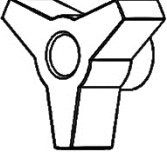
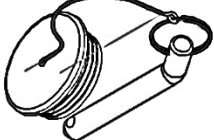
ITEM	HARDWARE TO SCALE	PART NUMBER	DESCRIPTION	QTY.
10		11541089	3/8" WASHER	21
11		0169791	3/8"-16 LOCK NUT	10
12		73815	3/8"-16 X 1" BUTTON HEAD CAP SCREW	10
13		13819	3/8"-16 X 3-1/2" HEX HEAD BOLT, FULL THREAD	2
14		37820	3/8"-16 X 3/4" COUPLING NUT	2
15		11541083	5/16" WASHER	27
16		0169777	5/16"-18 NYLOC	16
17		21810	5/16"-18 X 3/4" CARRIAGE BOLT	4
18		11138689	5/16-18 X 1" HEX HEAD BOLT	10
19		11101570	3/8"-16 3-ARM KNOB (1:2 SCALE)	2
20		13-00003	REAR PIN & CAP ASSY	2
21		-	SELF-LEVELING ADHESIVE SEALANT	1
22		26528	5/16" HEX WRENCH	1



**PRO II TRUCK RACK EXPLODED VIEW**

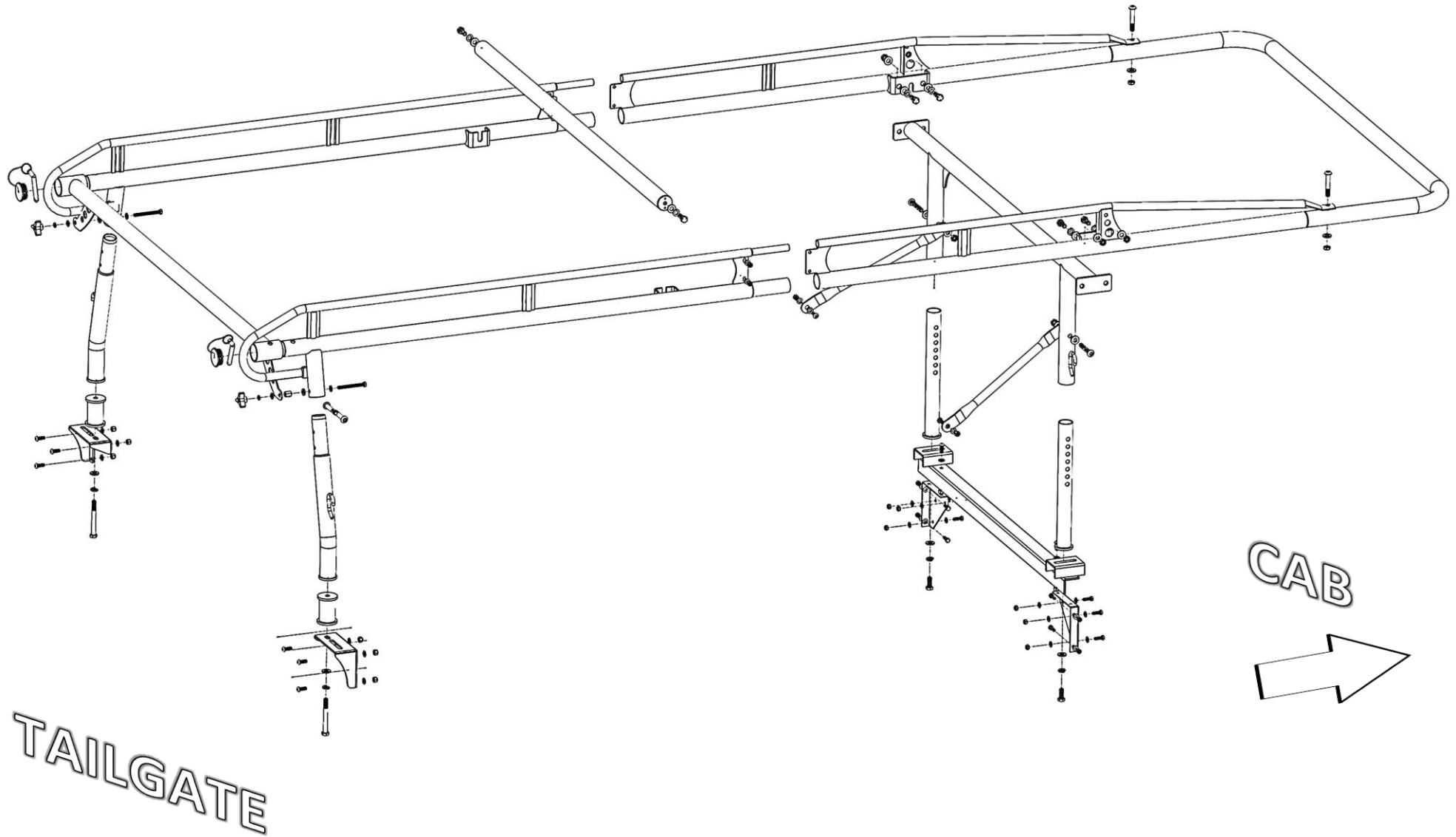

## Sealant Application

- Proper sealant application is critical to preventing water penetration inside the rack.
- Apply a healthy bead of sealant around every swaged joint as shown. Improper sealing can lead to water penetration and rust on inside surfaces.
- Wipe any excess sealant off immediately with a plastic scraper or paper towel. Any smeared sealant can be rubbed off as soon as sealant dries.
- Maintain this seal throughout the life of your rack.

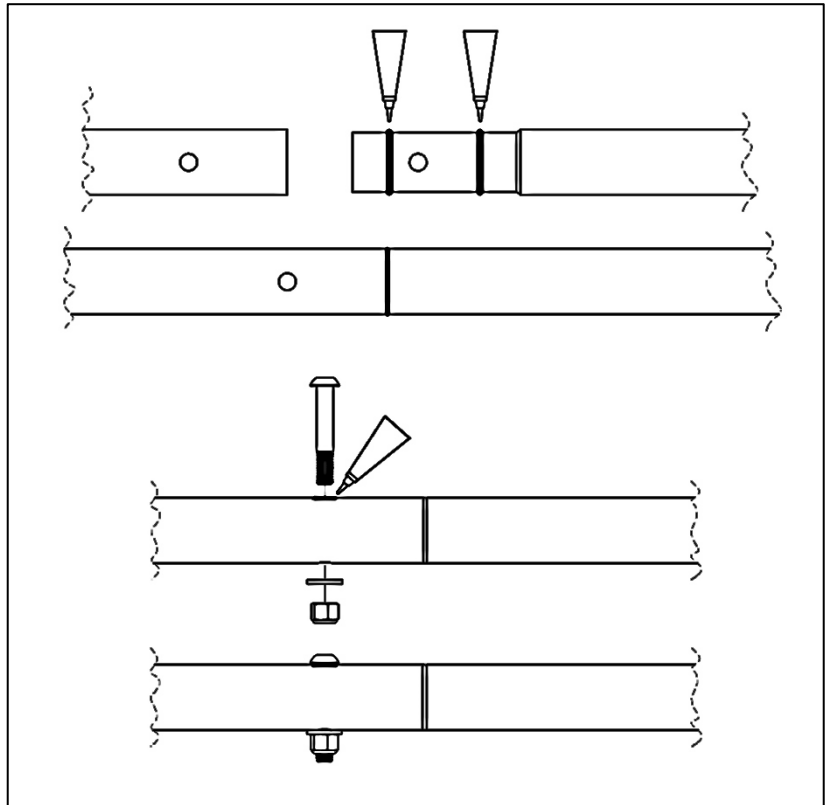

## Step 1 – Join Side Channels

- Be sure you have read the *Before You Begin* section above.
- Unpack side channels from box. Lay flattened box on ground and use for scratch protection while building rack.
- Open Assembly Hardware Kit.
- Be sure you have correct front and rear side channels paired.
- Apply sealant to both top and bottom swage joints per Sealant Application instructions above.
- Insert rear side-channel swaged joints into front side-channel tubes until bolt holes in splice plates align.
- Using 5/16" x 3/4" carriage bolts, 5/16" washers, and 5/16" lock nuts, securely fasten channels together.
- Remove excess sealant.
- Repeat process for opposite side.

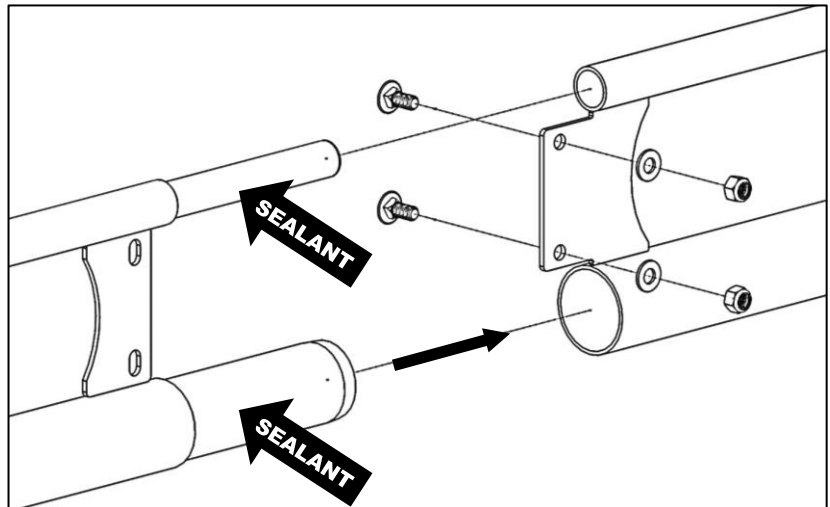

### **Step 2 – Attach Front Tube**

- Apply sealant to front side-channel swaged joint.
- Insert front side-channel swaged joint into front tube until bolt holes in tube and side-channel align.
- Loosely fasten front tube to side channel using 1/2" x 3" partially threaded button head screw, 1/2" washer, and 1/2" lock nut.
- Remove excess sealant.
- Repeat process on opposite side.

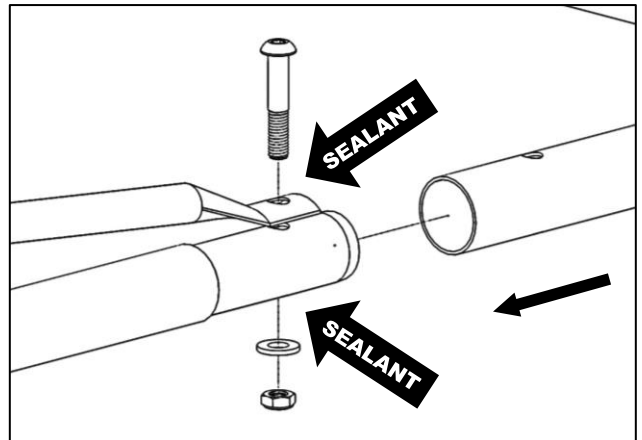

### **Step 3 – Attach Center Crossbar**

- Thread one 1/2" x 1-1/4" hex bolt, one 1/2" lock washer, and one 1/2" washer about 1/4" deep into each end of crossbar.
- Insert center crossbar into center crossbar bracket. Be sure 1/2" washers are NOT between crossbar and crossbar bracket.
- Just snugly tighten 1/2" bolts on both sides.

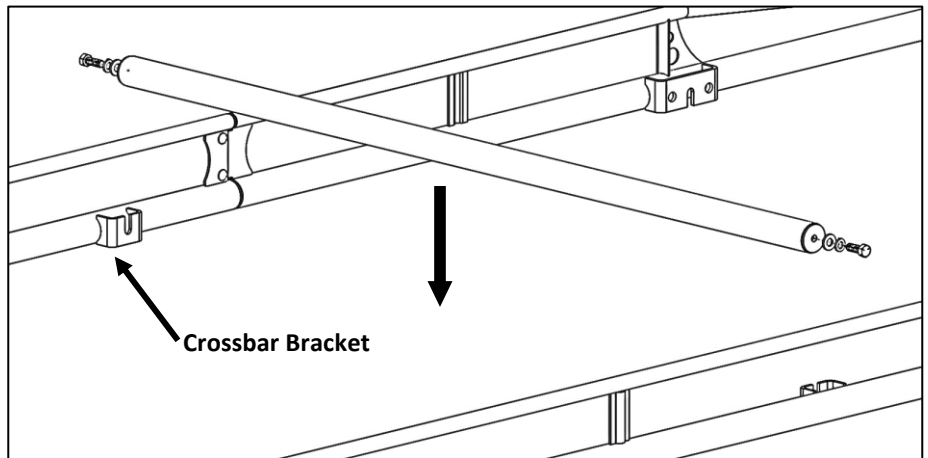

### **Step 4 – Attach Front Legs**

- Flip rack upside down.
- Fasten the front service body leg assembly to the saddle bracket on the front side channel using two 1/2" x 1-1/4" hex bolts, two 1/2" lock washers, four 1/2" flat washers, and two 1/2" lock nuts.
- Repeat on opposite side.

**NOTE: If using the 79000 or 79010 side channel kit, determine the appropriate saddle bracket to mount to, per service body length.**

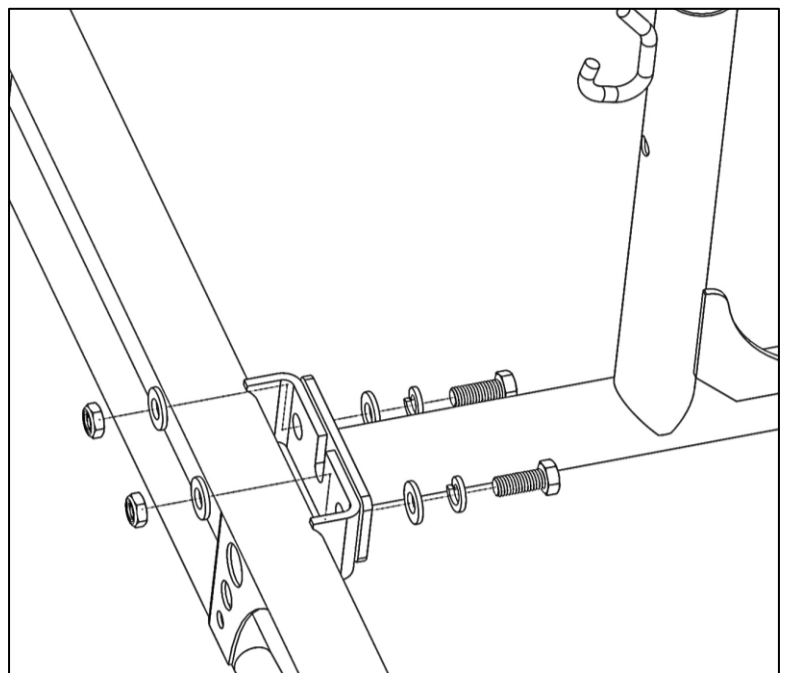

- Be sure to read the *Before You Begin* section before installing front legs.
- Based upon height of cab and clearance required, insert telescoping leg into leg assembly and then insert 1/2" x 3-1/4" bolt into holes through leg assembly.
- Place support arm over bolt and fasten 1/2" washer and 1/2" lock nut to bolt. Be sure bend in support arm is towards center of vehicle.
- Repeat on opposite side.

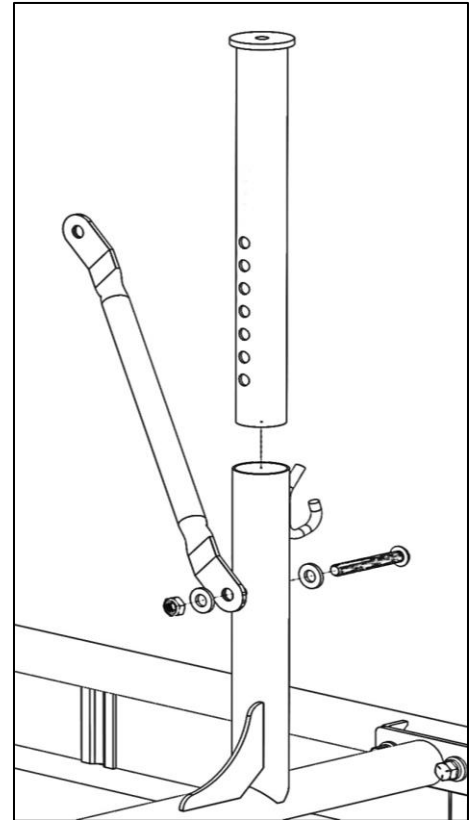

### **Step 5 – Attach Rear Legs**

- Apply sealant around swaged joint on one leg and around holes in leg cup.
- Orient leg correctly with side channel, with rope hook away from center of rack, and then insert leg into leg cup until holes through leg and leg cup align.
- Be sure to apply sealant around bolt between each washer and leg cup as you assemble.
- Fasten leg to leg cup using , one 3/8" x 3-1/2" fully-threaded hex head bolt, one 3/8" washers, one 3/8" oversize washer, and one 3/8" coupling nut. Make sure oversize washer and coupling nut are towards rear end of rack. Tighten 3/8" coupling nut to 3/8" x 3-1/2" fully threaded hex head bolt to 35 ft-lb.
- Remove excess sealant.
- Repeat process on opposite side.

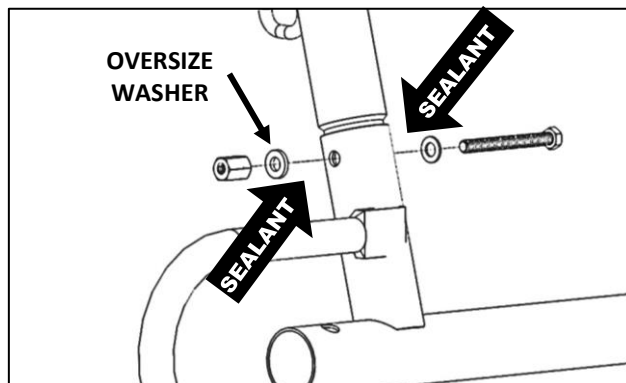
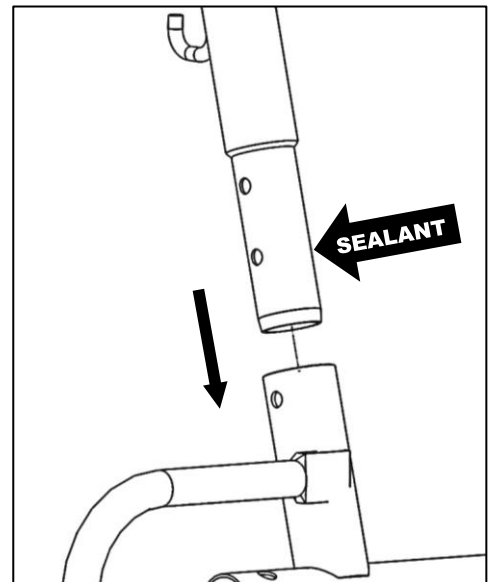

## Step 6 – Install Foot to Rack

Depending on the model of service body the rack is installed on, it may be necessary to install the rear feet pointed inwards instead of the typical rear foot installation pointed outwards.

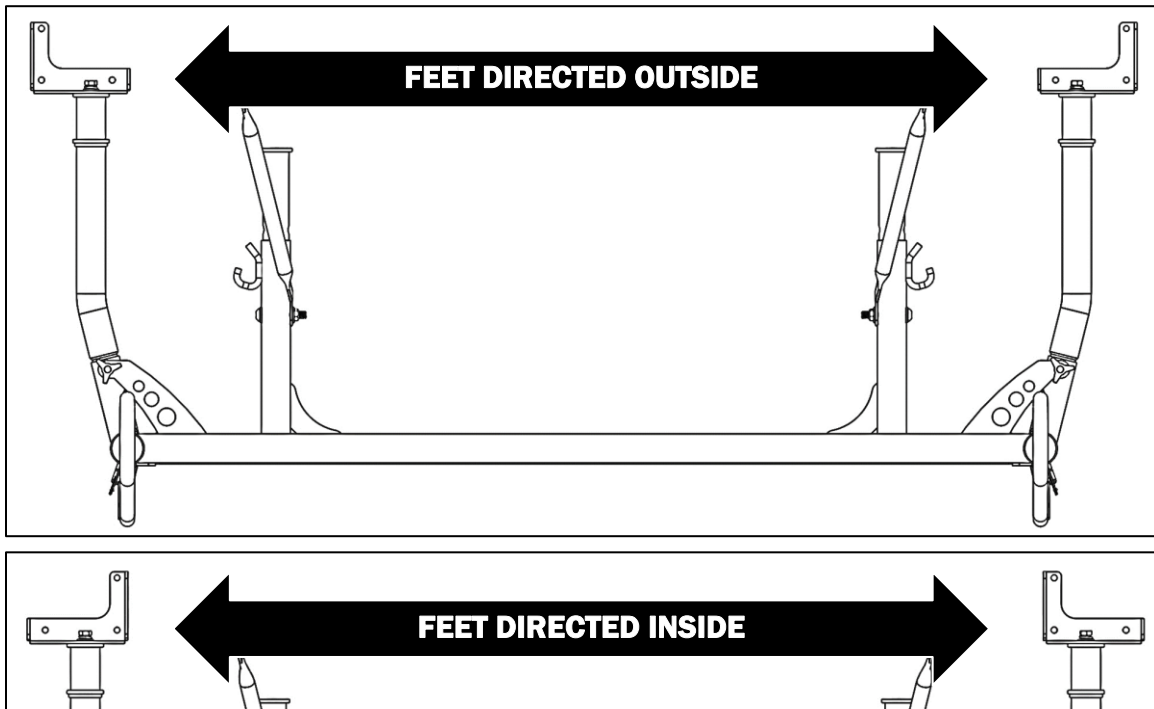

Also depending on the model of service body the rack is installed on, it may be necessary to install the 3" leg extension prior to installing the rear feet. If the service body has flip-open top lid door, then the extension is most likely necessary.

### If **NOT** installing the 3" extension:

- Using one 1/2" x 1-1/4" hex head bolt, one 1/2" lock washer, and one 1/2" washer, loosely install the rear foot to the rear leg.
- Snug tighten but allow for movement.
- Repeat on the opposite side.

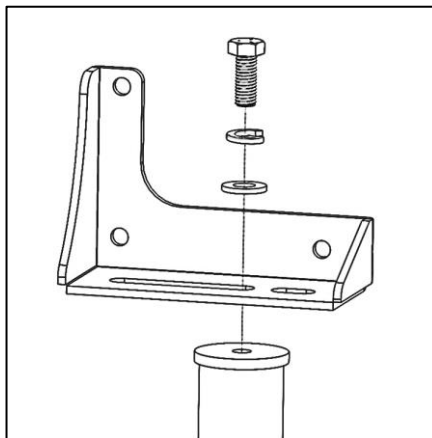

### If installing using the 3" extension:

- Using one 1/2" x 4-1/2" hex head bolt, one 1/2" lock washer, and one 1/2" washer, loosely install the rear foot and the 3" extension to the rear leg.
- Snug tighten but allow for movement.
- Repeat on the opposite side.

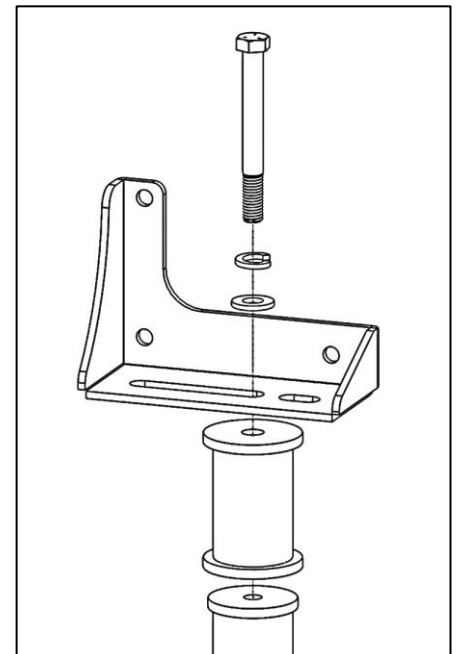

**Step 7 – Attach Rear Crossbar**

- Apply sealant around black cap fastening flanges.
- Using a mallet or dead blow hammer, tap black cap into rear crossbar tubing on the side opposite the gusset welded to the rear crossbar.
- Remove excess sealant.
- Repeat on opposite side.

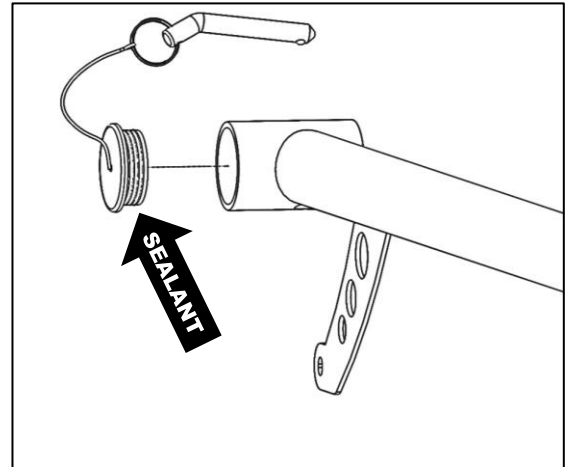

- Flip rack right side up.
- Slide rear crossbar ends onto rear side-channel tubes.
- Insert lock pin through holes in rear crossbar end and rear side-channel tube.
- Lightly fasten one side rear crossbar using one 3/8" knob, one 3/8" lock washer, and one 3/8" washer.
- Repeat on opposite side.

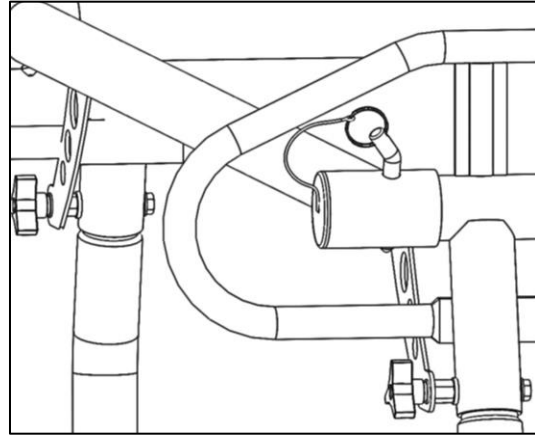
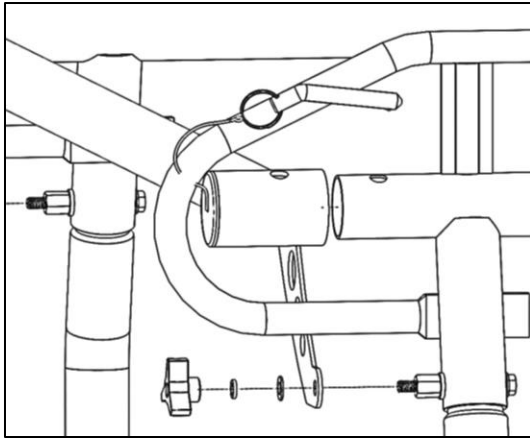

**Step 8 – Front Leg Angle Mount Installation**

- Set front leg angle mount on top of the bulkhead, with angle towards the rear of the bulkhead
- Center angle mount side-to-side.
- Mark holes in top of bulkhead.

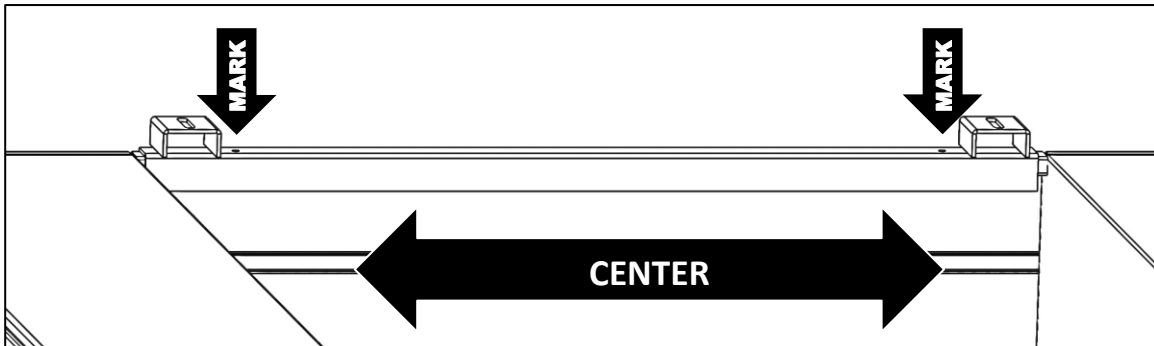

- Remove front leg angle mount.
- Using a 13/32" drill bit, drill a hole in the top of the bulkhead where marked.



**Be sure drilling location is clear of wires, fuel tanks and lines, brake lines and other important vehicle functionality items.**

- Using one 3/8" button head screw, two 3/8" washers, and one 3/8" lock nut, install angle mount to service body bulkhead.

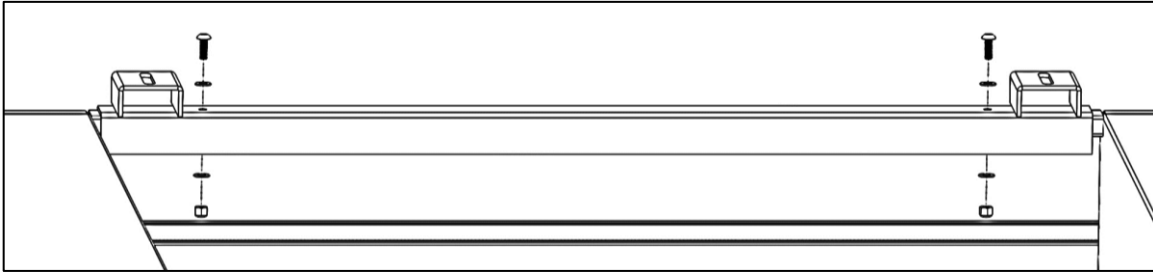

### Step 9 – Bulkhead Bracing Installation



**It is recommended that additional bracing be added to the service body bulkhead to support the truck rack. Some service bodies are not structurally designed to support loads upon the bulkhead without additional bracing.**

- Place the corner support against the inside of the bulkhead, against the top right side of the bulkhead flange or rail. The support should be touching three service body panels.
- Mark the location of the three holes against the bulkhead and the two holes to the service body interior sidewall.
- Repeat for the opposite side.
- Using an 11/32" drill bit, drill a hole in each location marked.

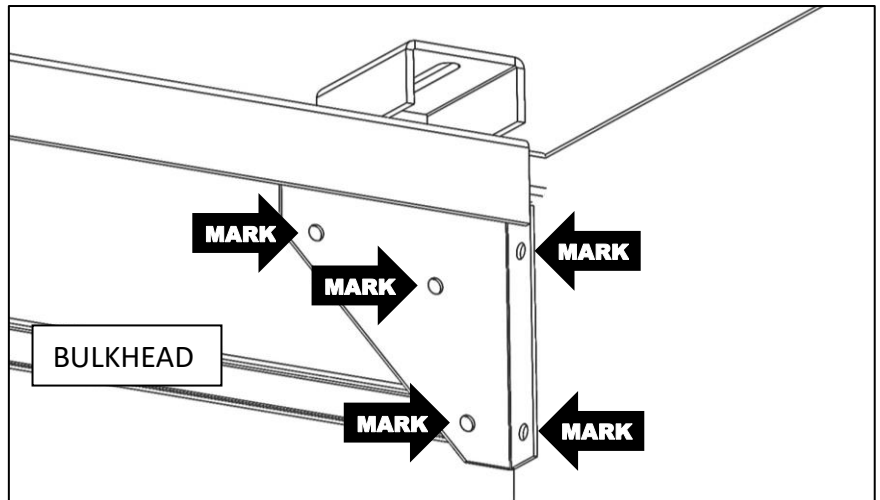

**Be sure drilling location is clear of wires, fuel tanks and lines, brake lines and other important vehicle functionality items.**



- Attach the corner support to the service body using one 5/16" bolt, two 5/16" washers, and one 5/16" lock nut for each hole drilled.
- Repeat on opposite side.

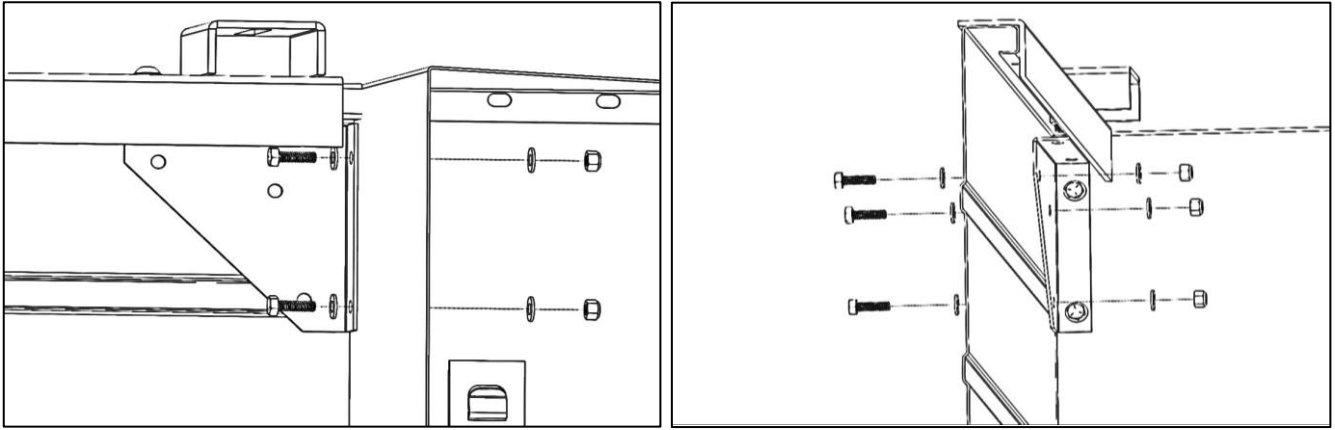

**Step 10 – Rear Foot to Service Body Installation**

- Lift rack and set legs onto front leg angle mount.
- Center the rack side-to-side over the bed.
- **Block, support, or hold rack in place, level to the service body.**
- Verify clearance above vehicle cab is as recommended on Page 2. If clearance needs adjustment, remove rack and adjust height of front legs as necessary.
- Loosely fasten front leg angle mount onto legs using two 1/2" x 1-1/4" hex bolts, two 1/2" lock washers, and two 1/2" washers.

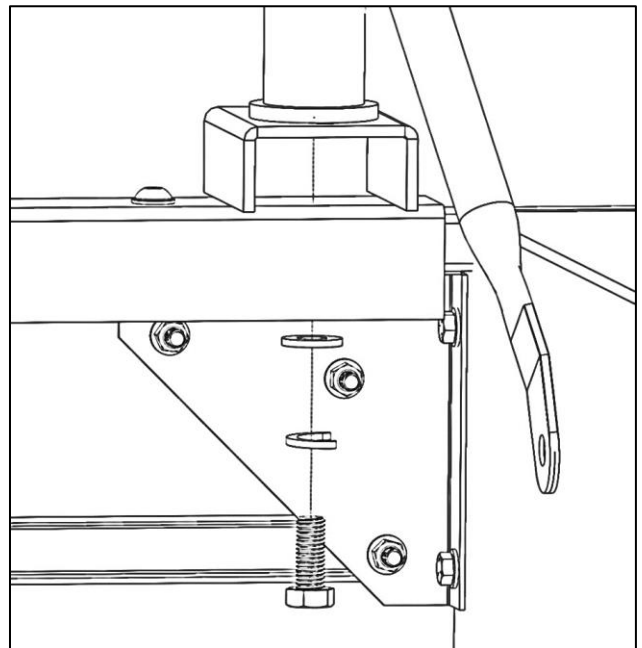

- Position rack with rear feet against rear of service body.
- Position rear feet as far from vehicle center and as close to vertical exterior corner of the rear body panel as possible. Be sure clearance is available inside rear panel of service for 3/8" washers and nuts.

**NOTE: If feet are reversed, position rear feet as far towards center and as close to vertical interior corner of the rear body panel as possible.**

- Mark location of holes in rear feet onto service body.
- Move feet out of the way.
- Using 13/32" drill bit, drill holes in rear of service body where marked.



**Be sure drilling location is clear of wires, fuel tanks and lines, brake lines and other important vehicle functionality items.**

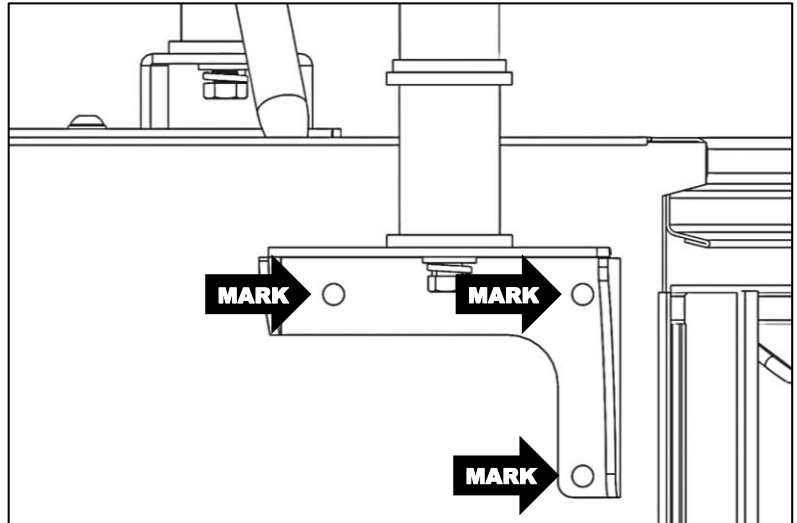

- Using three 3/8" x 1" button head screws, three 3/8" washers, and three 3/8" lock nuts for each side, securely fasten rear feet to rear of service body.

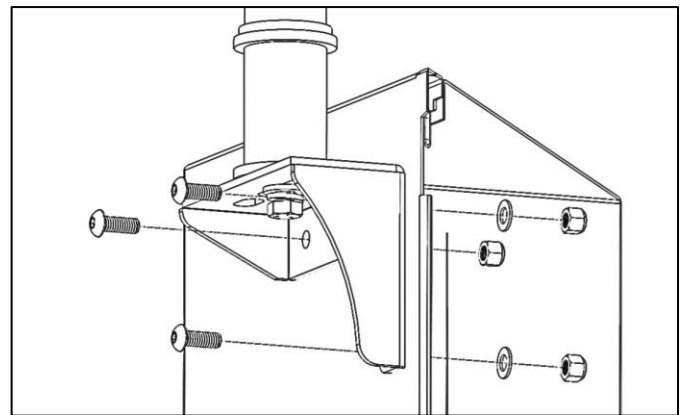

### **Step 11 – Support Arm Installation**

- Check that lower end of support arm is against inside of service body. If necessary, support arm may need to be moved to opposite side of front leg.
- Position support arm to as close to 45 degrees as possible while still allowing clearance for 3/8" washer and lock nut inside service body side panel. Be sure to allow clearance for flip top door if present.
- Mark location of hole in support arm onto service body side panel.
- Using 13/32" drill bit, drill holes through side panel of service body where marked.



**Be sure drilling location is clear of wires, fuel tanks and lines, brake lines and other important vehicle functionality items.**

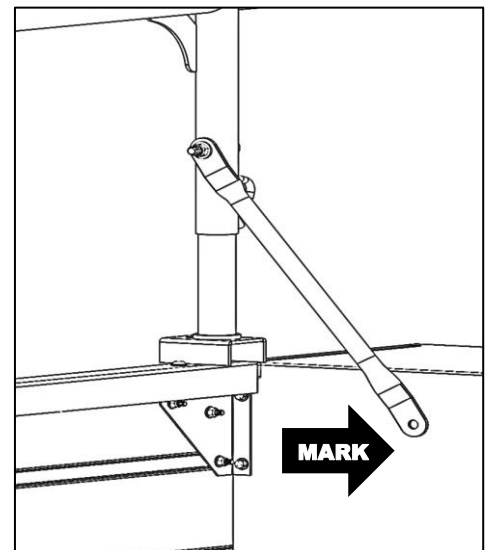

- Using one 3/8" button head screw, two 3/8" washers, and one 3/8" lock nut, loosely attach support arm to service body side panel.
- Snug tighten but allow for movement.
- Repeat for opposite side.

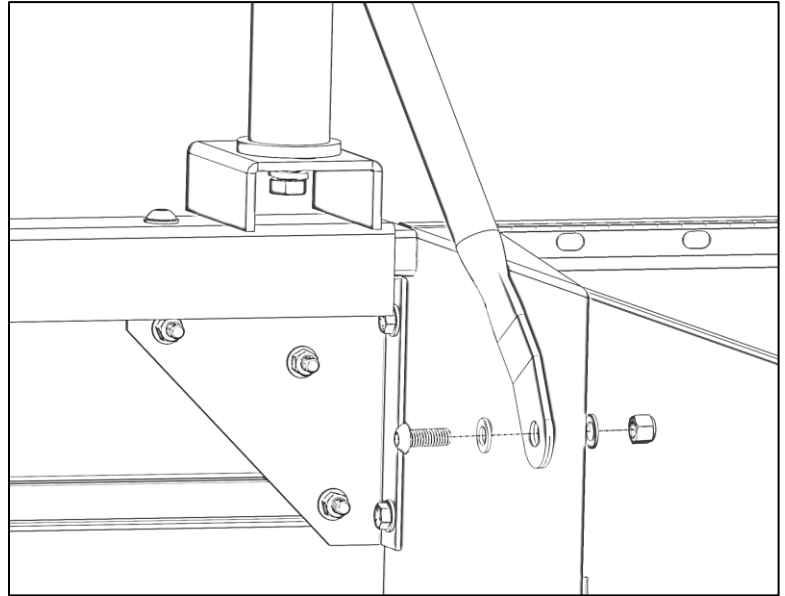

### **Step 12 – Rack Installation**

- With lock pins installed, tighten all side channel and upper front leg screws and bolts.
- Tighten center crossbar bolts.
- Securely fasten all foot screws and support arm screws.
- Ensure all hardware is tightened.
- Verify rear crossbar lock-pin pulls in and out easily. If necessary, loosen rear crossbar knobs and center crossbar, and then slide rear crossbar hard left then right about 10 times to get lock-pins to seat properly.

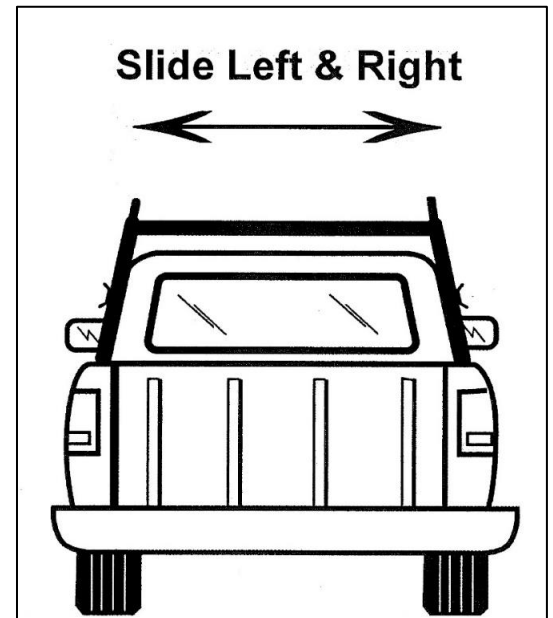

**DON'T OVERLOAD YOUR VEHICLE!**

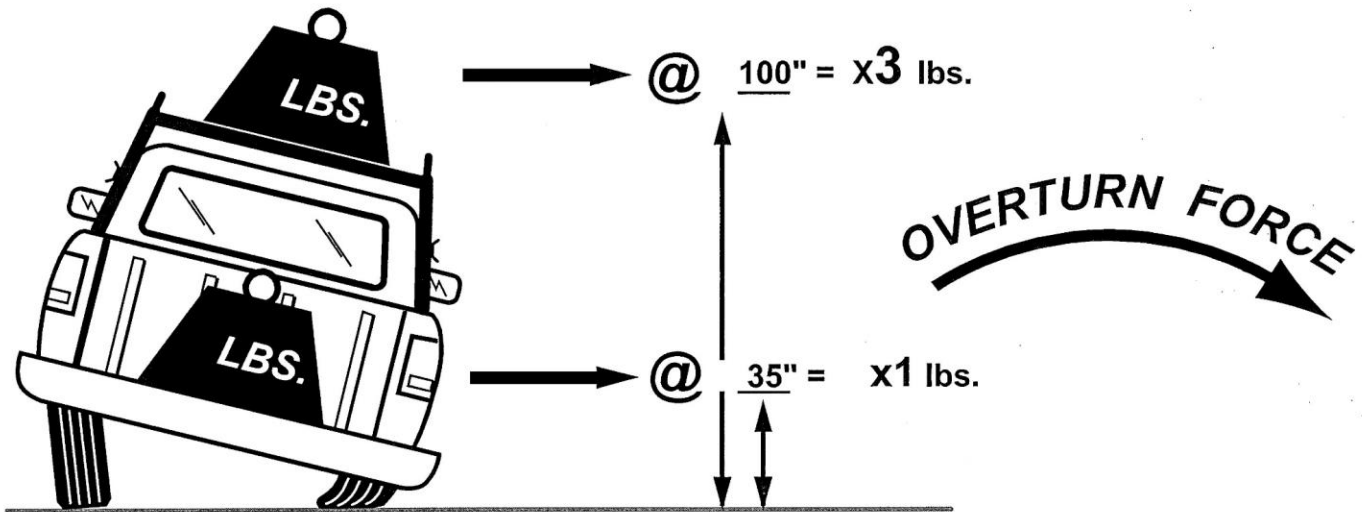

WEIGHT CARRIED ABOVE THE FLOOR OF THE TRUCK BED (E.G. ON AN OVERHEAD TRUCK RACK) WILL SIGNIFICANTLY INCREASE THE VEHICLE'S TENDENCY TO OVERTURN. ALWAYS KEEP HEAVY LOADS EVENLY DISTRIBUTED AND AS LOW AS POSSIBLE. IT IS IMPORTANT TO NOTE THAT THE KARGO MASTER RACK LOAD BEARING CAPACITY OF 1700 LBS. MAY BE GREATER THAN YOUR TRUCK'S GAWR OR GVWR CAPACITY, AND IS PROBABLY GREATER THAN THE WEIGHT THAT CAN BE SAFELY CARRIED OVERHEAD. RETIGHTEN ALL BOLTS AFTER FIRST USE, PERIODICALLY CHECK BOLTS FOR TIGHTNESS.

For *TECHNICAL SUPPORT* Call:

**1.800.343.7486**

[www.kargomaster.com](http://www.kargomaster.com)