

Holman

Instruction Guide 8010A

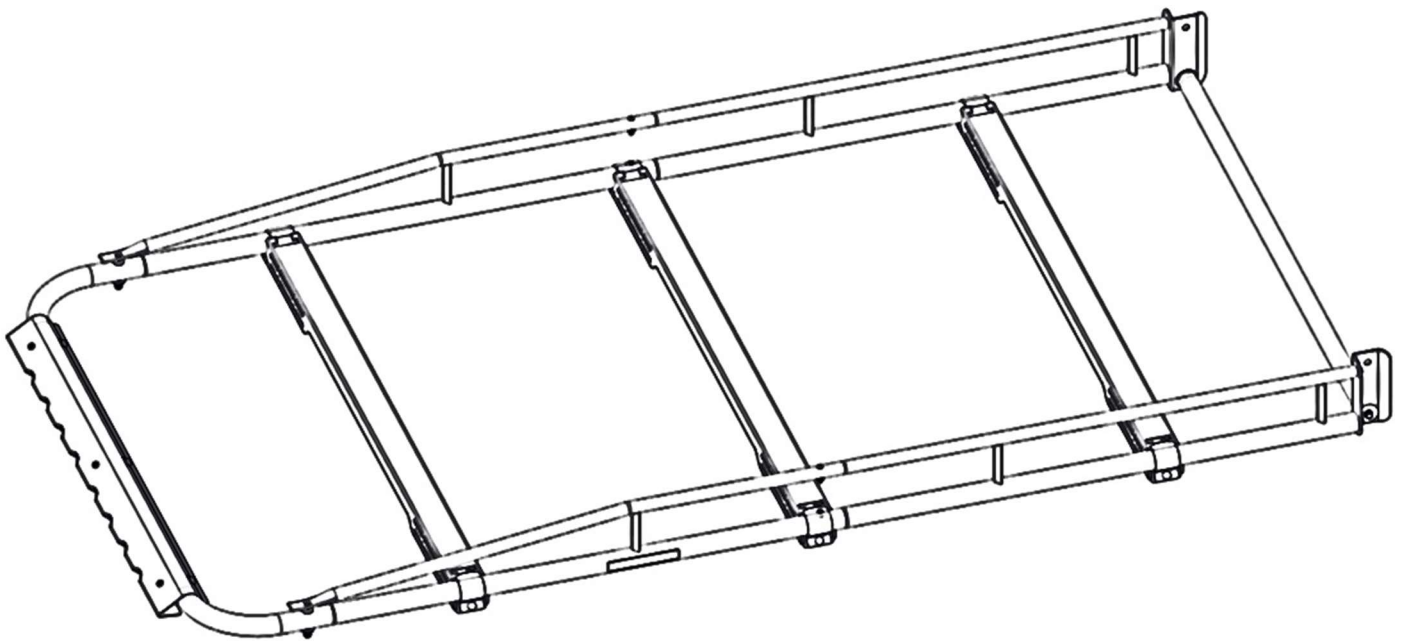

Holman
Rancho Cordova, CA 95742
800-343-7486

InstallationSupport@Holman.com

PLEASE READ ALL INSTRUCTIONS AND WARNINGS PRIOR TO ASSEMBLING, INSTALLING, AND USING THIS PRODUCT.

Warning



DO NOT EXCEED MANUFACTURERS WEIGHT CAPACITY FOR ROOF.



Secure all payloads properly for safe transportation.

Tools Needed

7/16", 1/2", 3/4" Sockets and Wrench	7/16", 1/2", 3/4" Box Wrenches
#2 Philips Screwdriver	3/16", 5/16" Allen Hex Wrenches

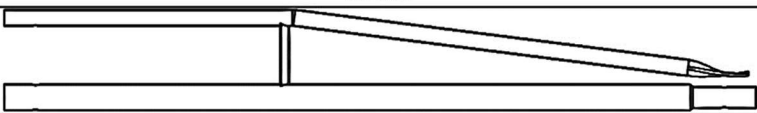
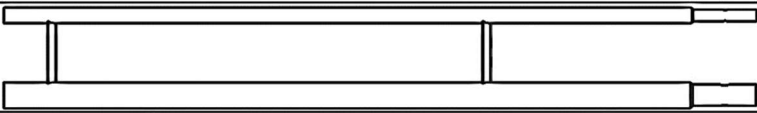

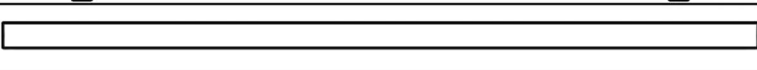
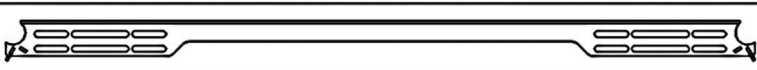
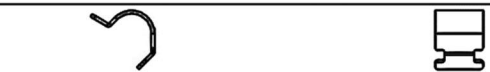

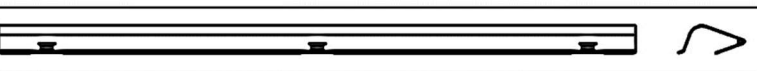

Table of Contents

Parts	2
Hardware (18-8010A)	2
Hardware (18-8000A-RB)	4
Hardware (18-31571)	4
Step 1 – Assemble Side Channels	5
Step 2 – Attach Roller Bar to Roller Bar Brackets	5
Step 3 – Attach Wind Deflector to Front Crossbar	6
Step 4 – Install Crossbars To Feet	6
Step 5 – Attach Side Channels to Crossbars.....	7
Step 6 – Attach Front Crossbar	8
Step 7 – Attach Roller Bar Assembly.....	8

Before You Begin

- Read all instructions prior to assembling or installing any Holman product.
- Always locate your installation locations prior to performing any work.
- **Be sure to put sealant around all threads entering cargo area and between the rubber spacer and roof of vehicle to prevent water from leaking into cargo area.**
- **HAVE THE MOUNTING KIT INSTALLED TO VEHICLE PRIOR TO INSTALLING THIS RACK.**
- **PROPER SEALANT APPLICATION IS CRITICAL TO PREVENTING WATER PENETRATION INSIDE THE RACK.** Apply a healthy bead of sealant entirely around every swaged joint and every bolt going through tubing. Improper sealing can lead to water penetration and rust on inside surfaces.







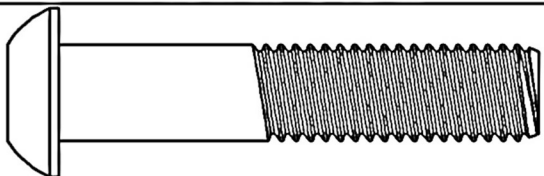
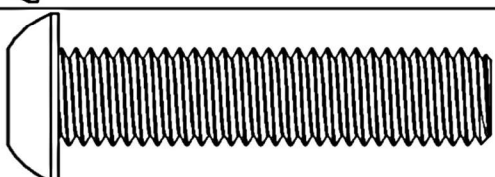

Parts

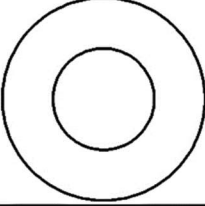
NO.	ITEM	PART NUMBER	DESCRIPTION	QTY.
1		8000A-01	FRONT SIDE CHANNEL	2
2		8000A-03	REAR SIDE CHANNEL	2
3		8000A-005	50" FRONT TUBE	1
4		8000A-05	50" ROLLER BAR	1
5		8000A-06	50" CROSSBAR WELDMENT	3
6		8000A-010	SIDE CHANNEL CLAMP	6
7		8000A-019	ROLLER BAR BRACKET, COMPACT VAN	2
8		101699	WIND DEFLECTOR	1
9		8000A-017	WIND DEFLECTOR CLAMP	3
10		18-8010A	HARDWARE KIT	1
11		18-8000A-RB	ROLLER BAR BOLT KIT	1
12		18-31571	HARDWARE KIT	1
13		LBL-004	6" X 1" HOLMAN DECAL, RECTANGULAR	2

Hardware (18-8010A)

ITEM	HARDWARE TO SCALE	PART NUMBER	DESCRIPTION	QTY.
1		92949A726	1/2"-13 x 2-1/2" Button Head Cap Screw	2
2		24114	1/2"-13 X 2-1/4" BUTTON HEAD	2
3		-	Self Leveling Adhesive Sealant	1

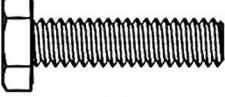
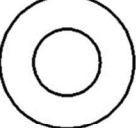
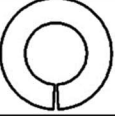
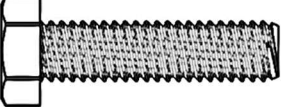
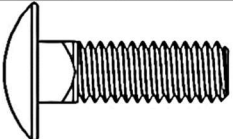

Hardware (18-8010A) (Continued)

ITEM	HARDWARE TO SCALE	PART NUMBER	DESCRIPTION	QTY.
4		11541086	1/2" WASHER	4
5		37695	1/2"-13 THIN LOCKING JAM NUT	4
6		92949A546	1/4-20 X 1 1/2 BUTTON HEAD	2
7		0167030	1/4"-20 FLANGED LOCK NUT	2
8		11545154	1/4" FLAT WASHER	2
9		1133618	1/4"-20 LOCK WASHER	2
10		11138676	1/4-20 X 1" HEX HEAD BOLT	2
11		92141A030	5/16" FLAT WASHER	2
12		1171067	5/16" LOCKING WASHER	2
13		11138690	5/16-18 X 1-1/4" HEX HEAD BOLT	2
14		74430	5/16-18 X 1" CARRIAGE BOLT	6
15		11104019	5/16-18 FLANGED NYLOCK NUT	6

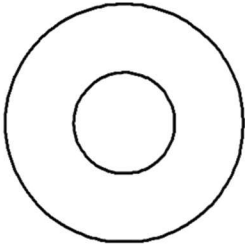
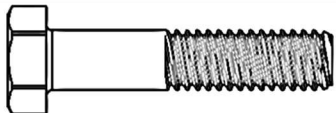
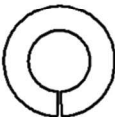
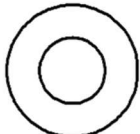
Hardware (18-8000A-RB)

ITEM	HARDWARE TO SCALE	PART NUMBER	DESCRIPTION	QTY.
1		6391K406	OIL-EMBEDDED BRONZE SLEEVE BEARING	2
2		95611A287	CHEMICAL-RESISTANT PVC PLASTIC WASHER FOR 1/2" SCREW SZ, 0.562" ID, 1.75" OD, 0.053"-0.071" THK	4
3		11241181	5/16"-18 X 1-1/2" HEX HEAD BOLT	2
4		1171067	5/16" LOCKING WASHER	2
5		11545144	5/16" FLAT WASHER	2

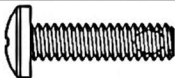
Hardware (18-31571)

ITEM	HARDWARE TO SCALE	PART NUMBER	DESCRIPTION	QTY.
1		0149489	10-32 X 3/4" PAN HEAD SCREW	3
2		33074	#10 FLAT WASHER	3

Sealant Application

- Proper sealant application is critical to preventing water penetration inside the rack.
- Apply a healthy bead of sealant around every swaged joint as shown. Improper sealing can lead to water penetration and rust on inside surfaces.
- Wipe any excess sealant off immediately with a plastic scraper or paper towel. Any smeared sealant can be rubbed off as soon as sealant dries.
- Maintain this seal throughout the life of your rack.

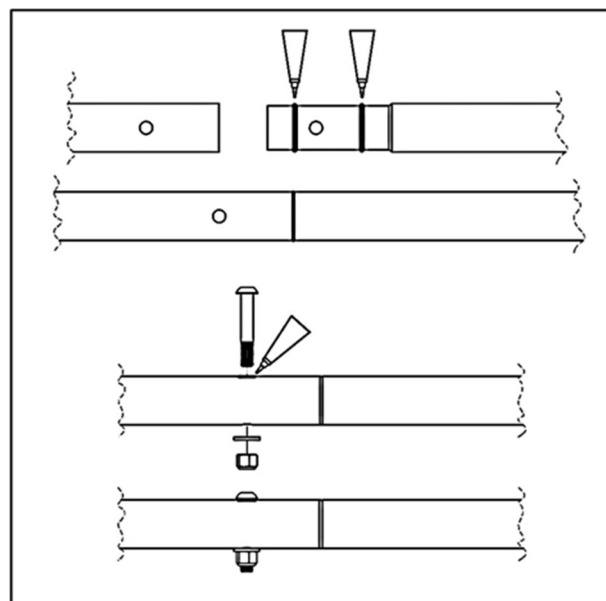

DO NOT EXCEED MANUFACTURERS WEIGHT CAPACITY FOR ROOF.

Step 1 – Assemble Side Channels

- Cover swage joints with sealant per Sealant Application guidelines. Push ends of front side channel onto swaged ends of center side channel.
- Using a 1/4" x 1-1/2" button head bolt and 1/4" flanged lock nut, bolt through UPPER side channel tubes.
- Using a 1/2" x 2-1/4" button head bolt, 1/2" flat washer, and 1/2" locking jam nut, bolt through LOWER side channel tubes.
- Remove excess sealant.
- Repeat for opposite side channel.
- Tighten the bolts going through top and bottom side-channel tubes.

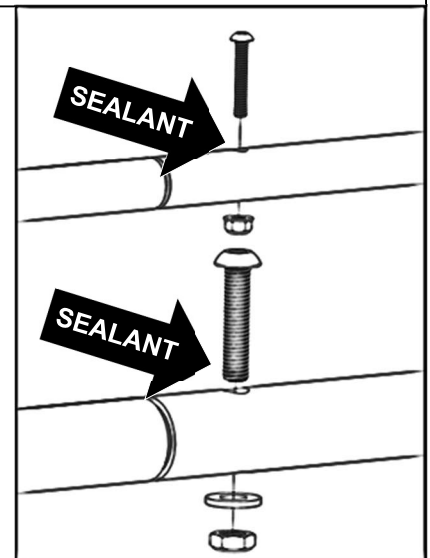
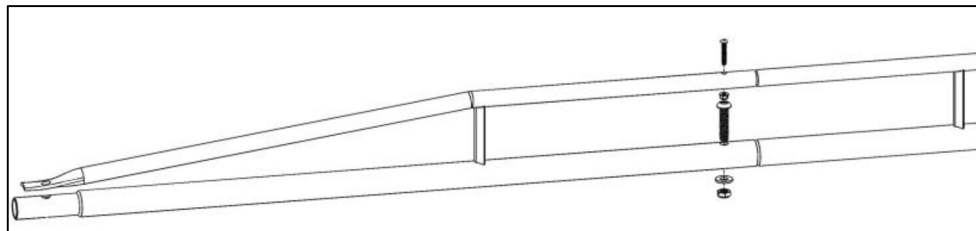
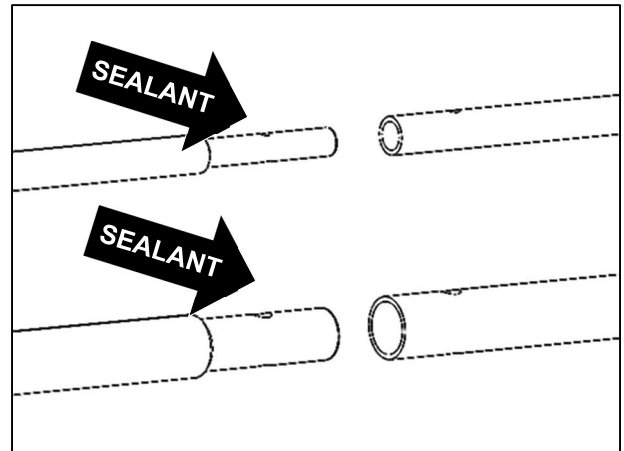

Step 2 – Attach Roller Bar to Roller Bar Brackets

Note: The lower roller bar mounting position is best for load bearing. Several positions are provided to accommodate different loading positions.

- Using a 5/16" x 1-1/2" hex head bolt, bolt through the following and into the end of the roller bar.
 - a 5/16" lock washer,
 - a 5/16" flat washer,
 - two plastic washers (one on each side of roller bar bracket),
 - a roller bar bracket, and
 - a roller bearing

Be sure flanges are facing away from each other and away from center of roller bar.

- Repeat for opposite side.

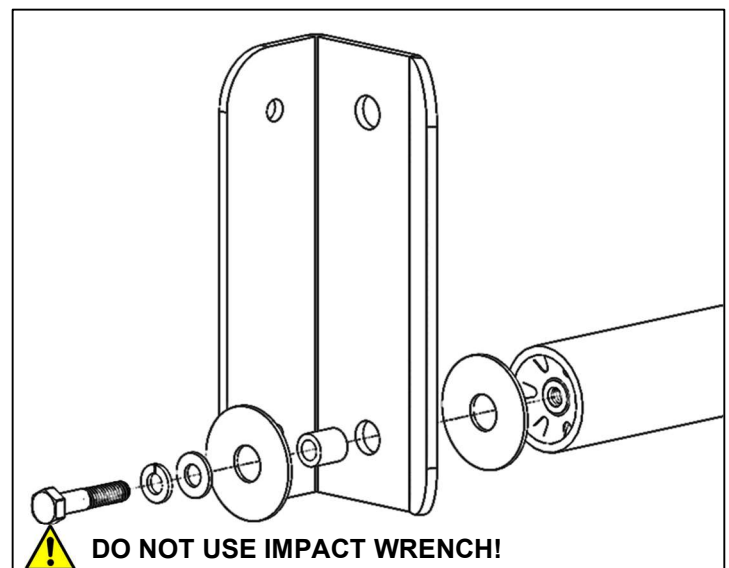

Step 3 – Attach Wind Deflector to Front Crossbar

- Insert wind deflector clamp-retainer into cutout in wind deflector.

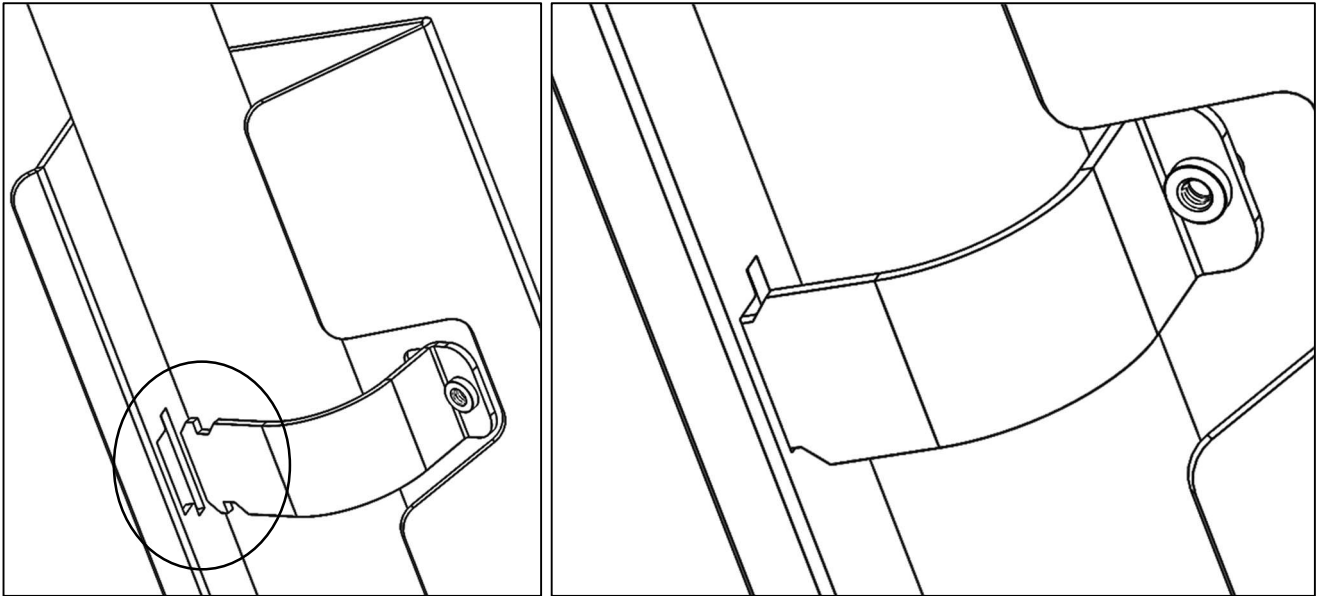

- Hold wind deflector in position with angled edge aimed towards front of vehicle.
- Use a #10 x 3/4" pan head screw and #10 washer to bolt through the wind deflector into the press nut in the clamp.
- Repeat for remaining two clamps.
- Tighten.

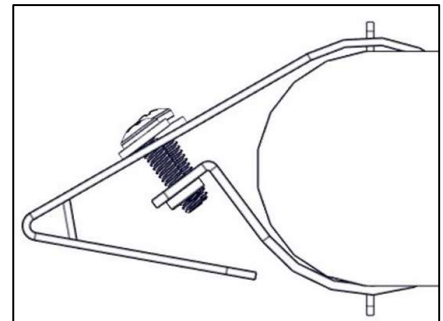

Step 4 – Install Crossbars To Feet

NOTE: Hardware to attach crossbars to feet is included in mounting kit.

- Set crossbar onto feet. Mounting feet may be installed into either upper or lower slots, based upon clearance required for vehicle.
- Center crossbar right-to-left with feet and vehicle.

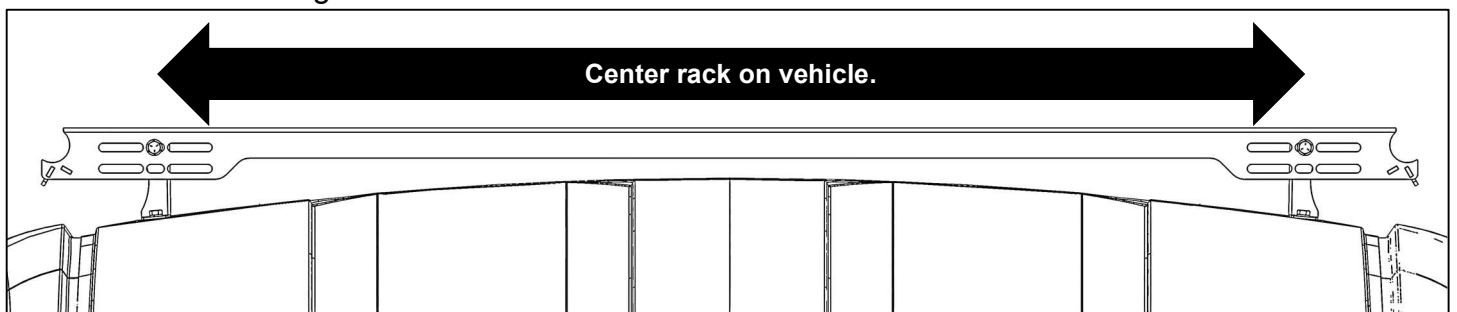

- Using 3/8" x 1" hex head bolts, 3/8" lock nuts, and 3/8" flat washers provided with mounting kit, bolt crossbar to feet.
- Tighten but allow movement.
- Repeat for all remaining crossbars.

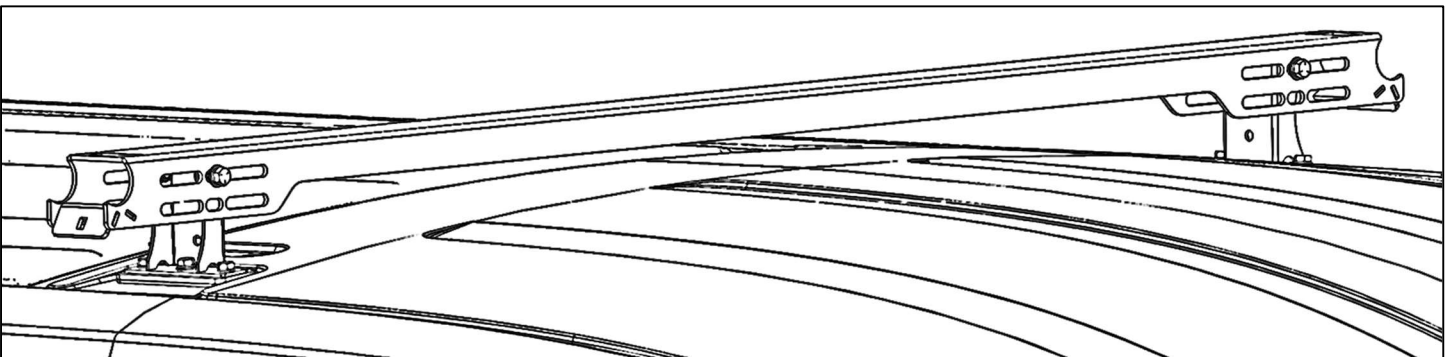
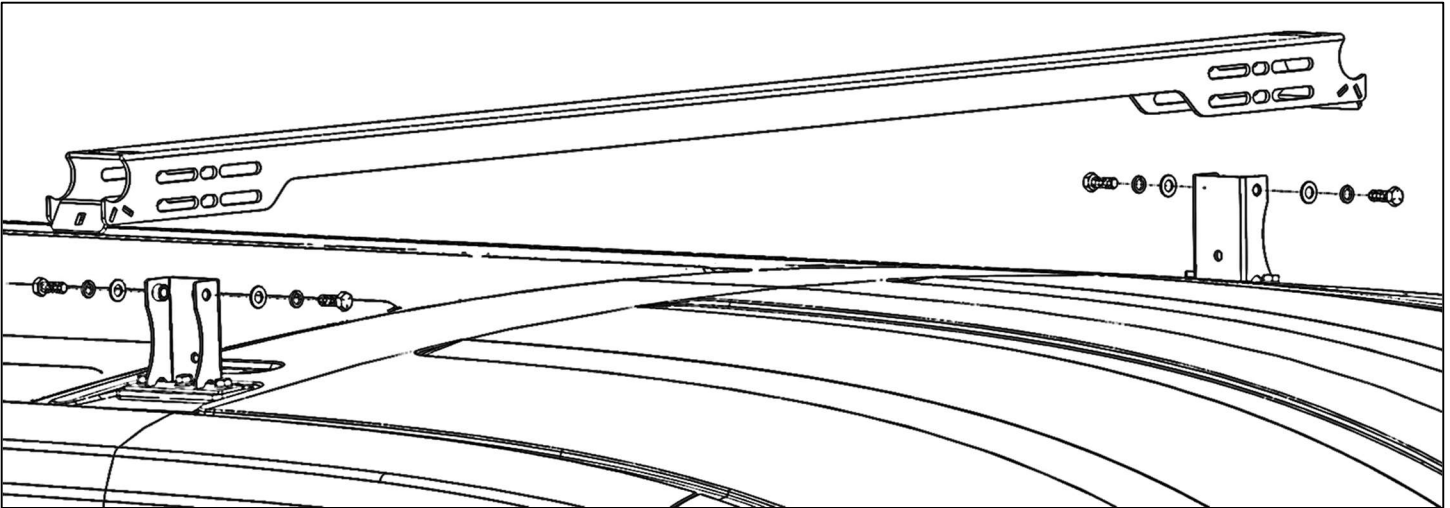

Step 5 – Attach Side Channels to Crossbars

- Set side channel into round cutout in crossbars in desired position.
- Although rack position may be adjusted later, it is recommended to determine the front-to-back position of the rack at this point.
- Insert a side channel clamp into cutout in each crossbar with interior diameter facing upward.

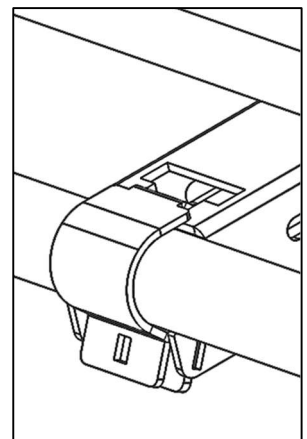
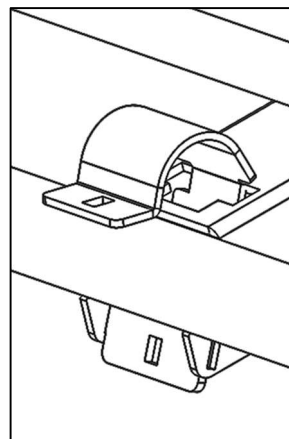
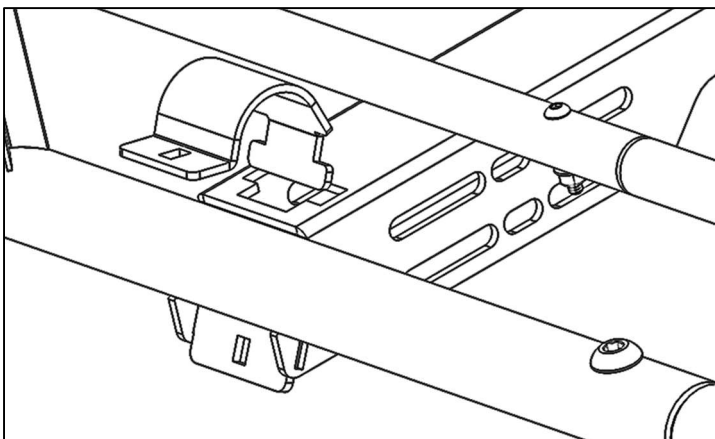

- For each side channel clamp, use a 5/16" x 1" carriage bolt and 5/16" flanged lock nut to bolt side channel clamp to crossbar.
- Snug tighten but allow for movement.

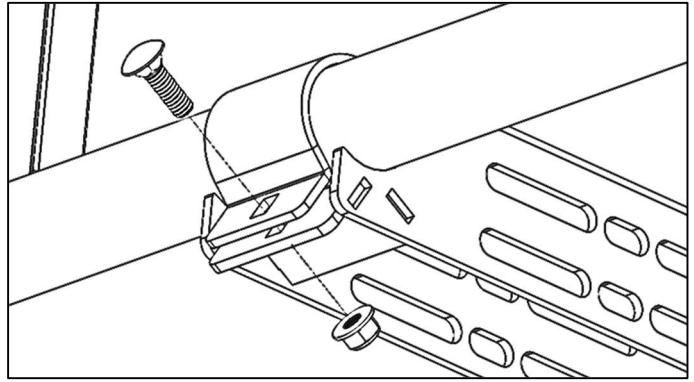

Step 6 – Attach Front Crossbar

- Cover swage joints with sealant per Sealant Application guidelines. Push front crossbar onto swaged end of front side channel. Be sure to align holes in both and be sure flat face of wind deflector is on top.
- Using a 1/2" x 2-1/2" button head cap screw, 1/2" flat washer, and 1/2" locking jam nut, bolt through front side channel and front crossbar.
- Remove excess sealant.
- Tighten.
- Repeat for opposite side.

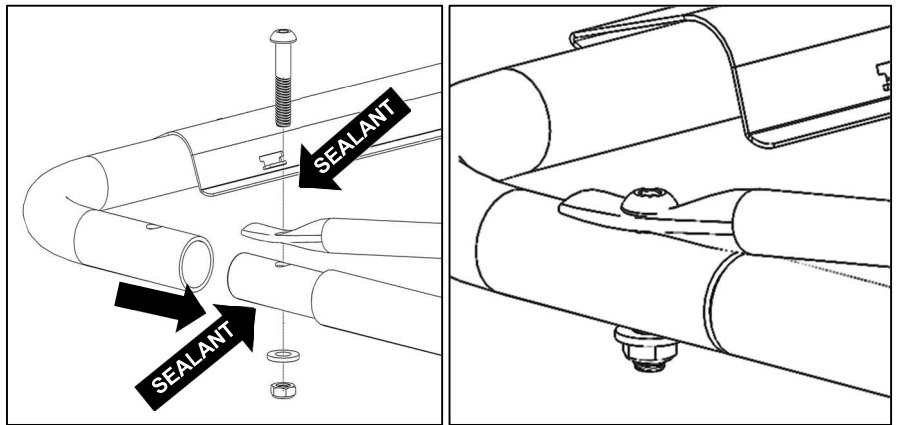

Step 7 – Attach Roller Bar Assembly

- Using a 1/4" x 1" hex head bolt, 1/4" lock washer, and 1/4" flat washer, bolt through the TOP hole in the roller bar bracket into end of the TOP rear side channel.
- Using a 5/16" x 1-1/4" hex head bolt, 5/16" lock washer, and 5/16" flat washer, bolt through the BOTTOM hole in the roller bar bracket into end of the BOTTOM rear side channel.
- TIGHTEN hardware.
- Repeat for opposite side.
- **Check that the rack is square to the vehicle and mounts.**

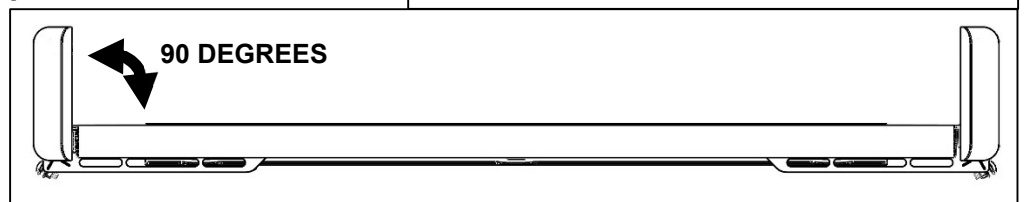
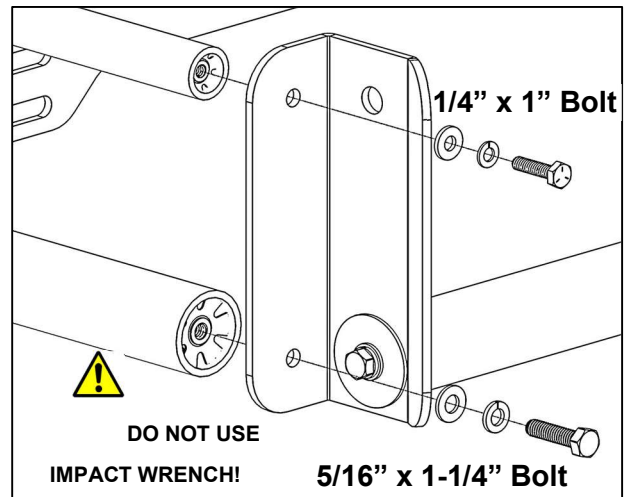

- Be sure the rear roller bar is hanging off the rear of the vehicle enough so that when placing a ladder on the rack, it does not come into contact with the rear of the vehicle.

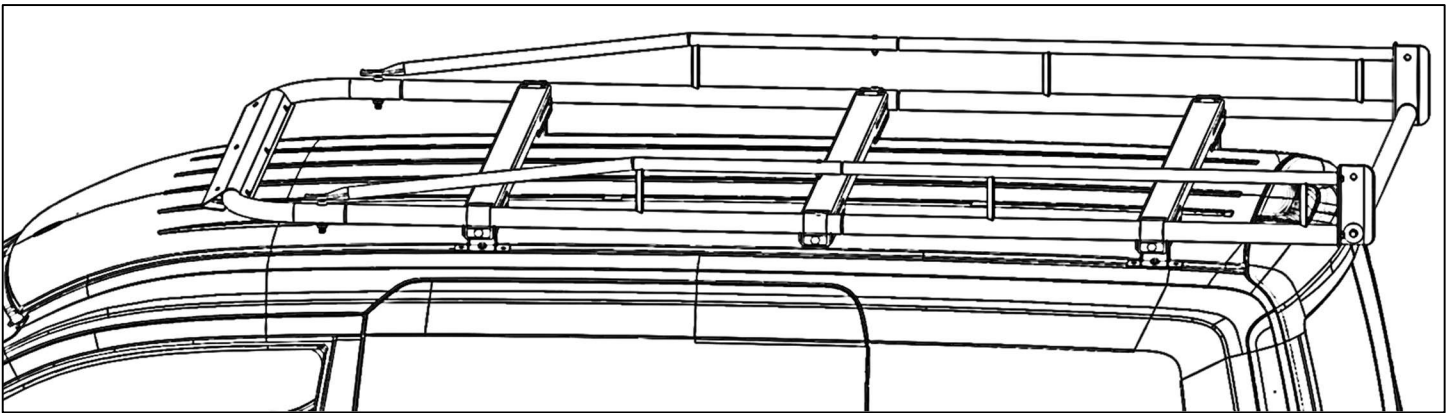
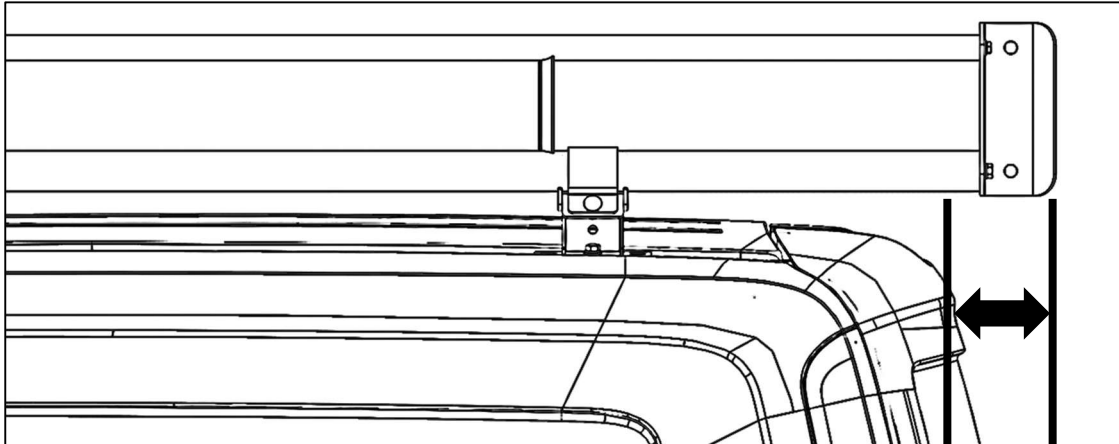

GO BACK AND TIGHTEN ALL HARDWARE.

INSTALLATION AND ASSEMBLY ARE COMPLETE.