

# Holman

---

## Instruction Guide 8008A

---

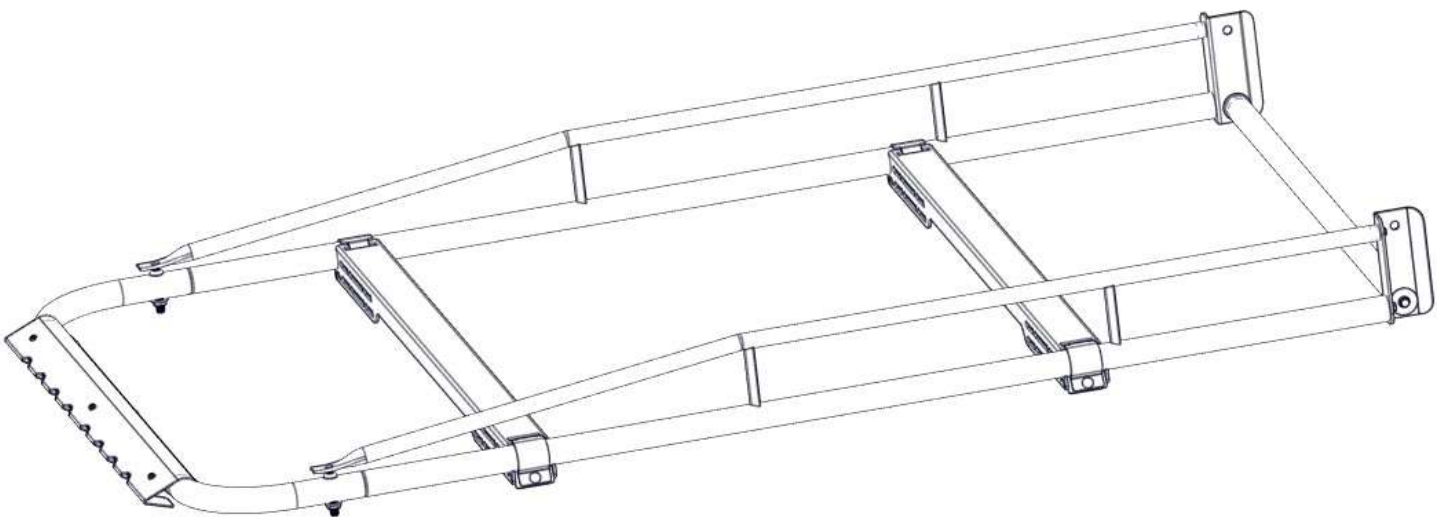

---

Holman  
Rancho Cordova, CA 95742  
800-343-7486

[InstallationSupport@Holman.com](mailto:InstallationSupport@Holman.com)

## PLEASE READ ALL INSTRUCTIONS AND WARNINGS PRIOR TO ASSEMBLING, INSTALLING, AND USING THIS PRODUCT.

### Warning



**DO NOT EXCEED MANUFACTURERS WEIGHT CAPACITY FOR ROOF.**



**Secure all payloads properly for safe transportation.**

### Tools Needed

7/16", 1/2", 3/4" Socket and Wrench	7/16", 1/2", 3/4" Box Wrenches
#2 Philips Screwdriver	3/8" Hex Key Allen Wrench







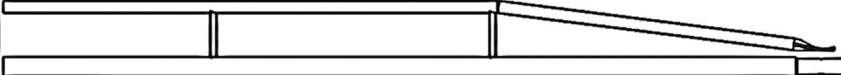

### Table of Contents

Parts .....	2
Hardware (18-8008A) .....	2
Hardware (18-8000A-RB) .....	4
Hardware (18-31571) .....	4
Sealant Application .....	4
Step 1 – Attach Roller Bar to Roller Bar Brackets .....	5
Step 2 – Attach Wind Deflector to Front Crossbar .....	5
Step 3 – Install Crossbars To Feet .....	6
Step 4 – Attach Side Channels to Crossbars.....	7
Step 5 – Attach Front Crossbar .....	7
Step 6 – Attach Roller Bar Assembly.....	8

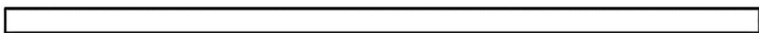
### Before You Begin

- Read all instructions prior to assembling or installing any Holman product.
- Always locate your installation locations prior to performing any work.
- **Be sure to put sealant around all threads entering cargo area and between the rubber spacer and roof of vehicle to prevent water from leaking into cargo area.**
- **HAVE THE MOUNTING KIT INSTALLED TO VEHICLE PRIOR TO INSTALLING THIS RACK.**
- **PROPER SEALANT APPLICATION IS CRITICAL TO PREVENTING WATER PENETRATION INSIDE THE RACK. Apply a healthy bead of sealant entirely around every swaged joint and every bolt going through tubing. Improper sealing can lead to water penetration and rust on inside surfaces.**

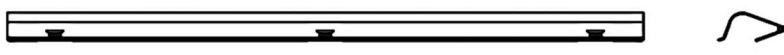

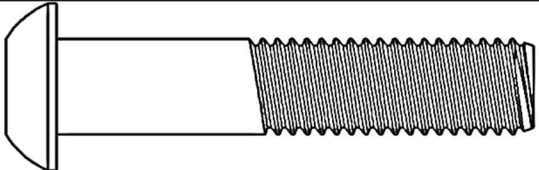
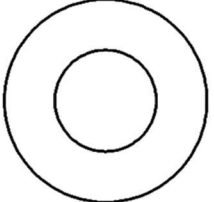

## Parts

NO	ITEM	PART NUMBER	DESCRIPTION	QTY
1		8008A-01	SIDE 80" RACK	2
2		8000A-005	50" FRONT TUBE	1
3		8000A-05	50" ROLLER BAR	1
4		8000A-06	50" CROSSBAR WELDMENT	2
5		8000A-010	SIDE CHANNEL CLAMP	4
6		8000A-019	ROLLER BAR BRACKET, COMPACT VAN	2
7		101699	WIND DEFLECTOR	1
8		8000A-017	WIND DEFLECTOR CLAMP	3
9		18-8008A	ASSEMBLY BOLT KIT	1
10		18-8000A-RB	ROLLER BAR BOLT KIT	1
11		18-31571	HARDWARE KIT	1

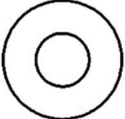

## Hardware (18-8008A)

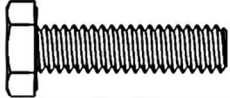
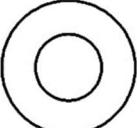
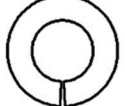
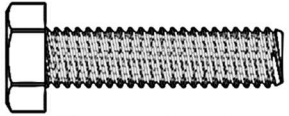
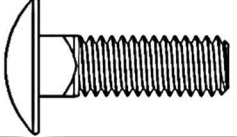
ITEM	HARDWARE TO SCALE	PART NUMBER	DESCRIPTION	QTY.
1			.50 X 2.5" BUTTON HEAD	2
2		11541086	1/2" WASHER	2

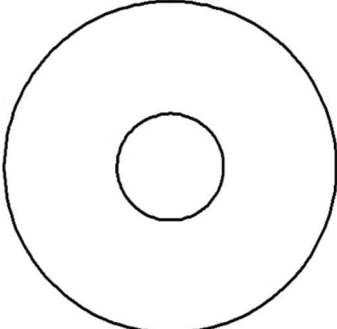
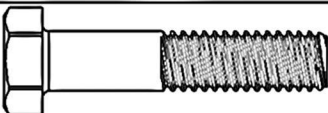

## Hardware (18-8008A) (Continued)

ITEM	HARDWARE TO SCALE	PART NUMBER	DESCRIPTION	QTY.
3		37695	1/2"-13 THIN LOCKING JAM NUT	2
4		33078	1/4" FLAT WASHER	2
5		1133618	1/4"-20 LOCK WASHER	2
6		13005	1/4-20 X 1" HEX HEAD BOLT	2
7		92141A030	5/16" FLAT WASHER	2
8		1171067	5/16" LOCKING WASHER	2
9		11138690	5/16-18 X 1-1/4" HEX HEAD BOLT	2
10		21811	5/16-18 X 1" CARRIAGE BOLT	4
11		11104019	5/16-18 FLANGED NYLOCK NUT	4
12		E6000	SELF LEVELING ADHESIVE SEALANT	1

## Hardware (18-8000A-RB)

ITEM	HARDWARE TO SCALE	PART NUMBER	DESCRIPTION	QTY.
1		6391K406	OIL-EMBEDDED BRONZE SLEEVE BEARING	2
2		95611A287	CHEMICAL-RESISTANT PVC PLASTIC WASHER FOR 1/2" SCREW SZ, 0.562" ID, 1.75" OD, 0.053"-0.071" THK	4
3		11241181	5/16"-18 X 1-1/2" HEX HEAD BOLT	2
4		1171067	5/16" LOCKING WASHER	2
5		11545144	5/16" FLAT WASHER	2

## Hardware (18-31571)

ITEM	HARDWARE TO SCALE	PART NUMBER	DESCRIPTION	QTY.
1		0149489	10-32 X 3/4" PAN HEAD SCREW	3
2		33074	#10 FLAT WASHER	3

## Sealant Application

Proper sealant application is critical to preventing water penetration inside the rack.

Apply a healthy bead of sealant around every swaged joint as shown. Improper sealing can lead to water penetration and rust on inside surfaces.

Wipe any excess sealant off immediately with a plastic scraper or paper towel. Any smeared sealant can be rubbed off as soon as sealant dries.

Maintain this seal throughout the life of your rack.

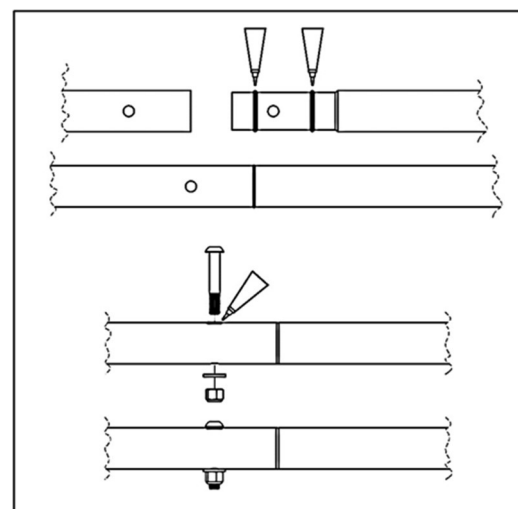

## DO NOT EXCEED MANUFACTURERS WEIGHT CAPACITY FOR ROOF.

### Step 1 – Attach Roller Bar to Roller Bar Brackets

**Note:** The center roller bar mounting position is best for load bearing. Several positions are provided to accommodate different loading positions.

- Using a 5/16" x 1-1/2" hex head bolt, bolt through the following and into the end of the roller bar.
  - a 5/16" lock washer,
  - a 5/16" flat washer,
  - two plastic washers (one on each side of roller bar bracket),
  - a roller bar bracket, and
  - a roller bearing,

**Be sure flanges are facing away from each other and away from center of roller bar.**

- Repeat for opposite side.

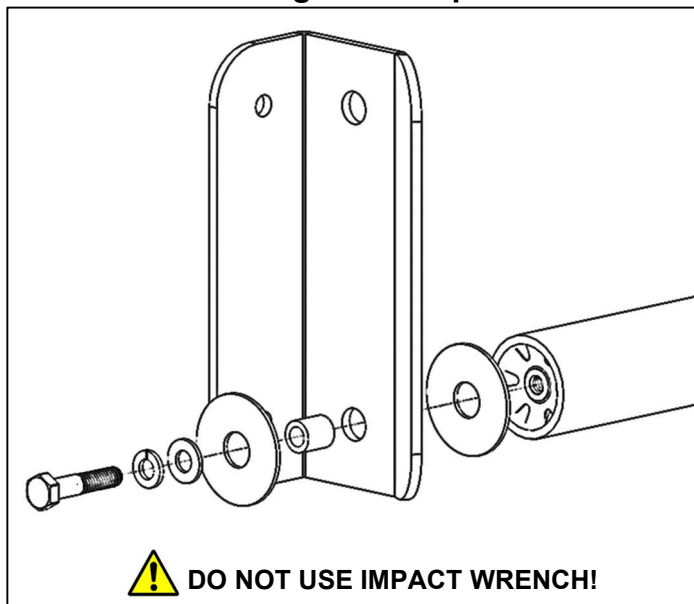

### Step 2 – Attach Wind Deflector to Front Crossbar

- Insert wind deflector clamp-retainer into cutout in wind deflector.

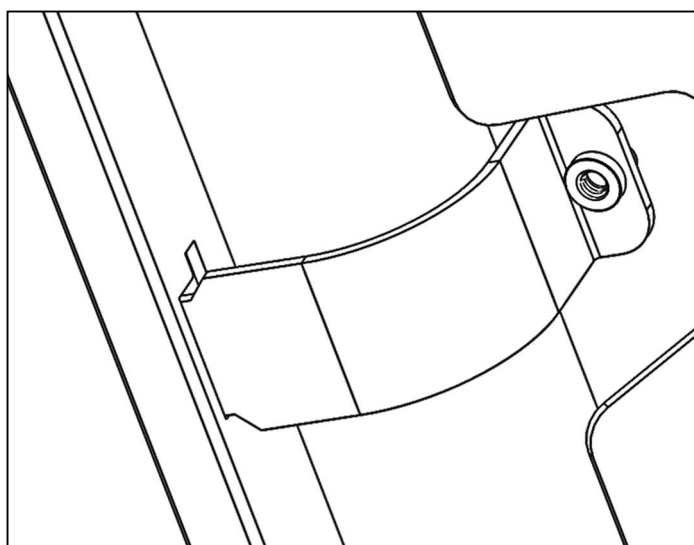
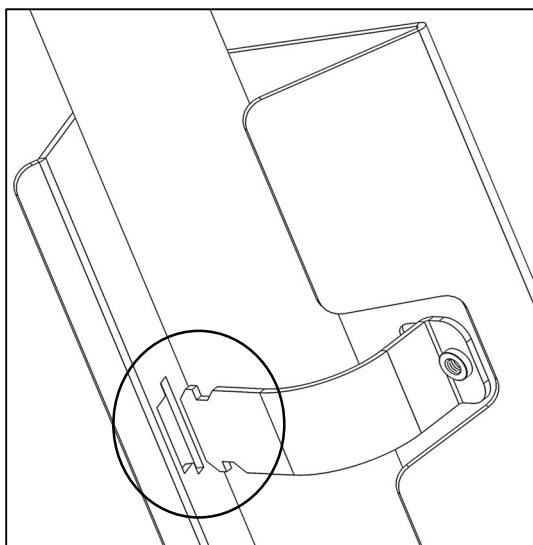

- Hold wind deflector in position with angled edge aimed towards front of vehicle.
- Use a #10 x 3/4" pan head screw and #10 washer to bolt through the wind deflector into the press nut in the clamp.
- Repeat for remaining two clamps.
- Tighten.

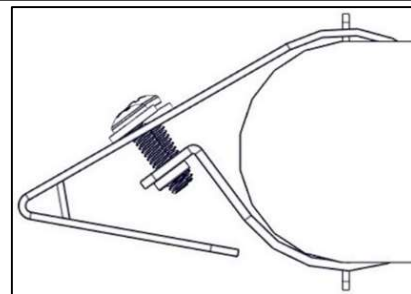

## Step 3 – Install Crossbars To Feet

**NOTE: HARDWARE TO ATTACH CROSSBARS TO FEET IS INCLUDED IN MOUNTING KIT.**

- Set crossbar onto feet. **Mounting feet may be installed into either upper or lower slots, based upon clearance required for vehicle.**
- Center crossbar right-to-left with feet and vehicle.

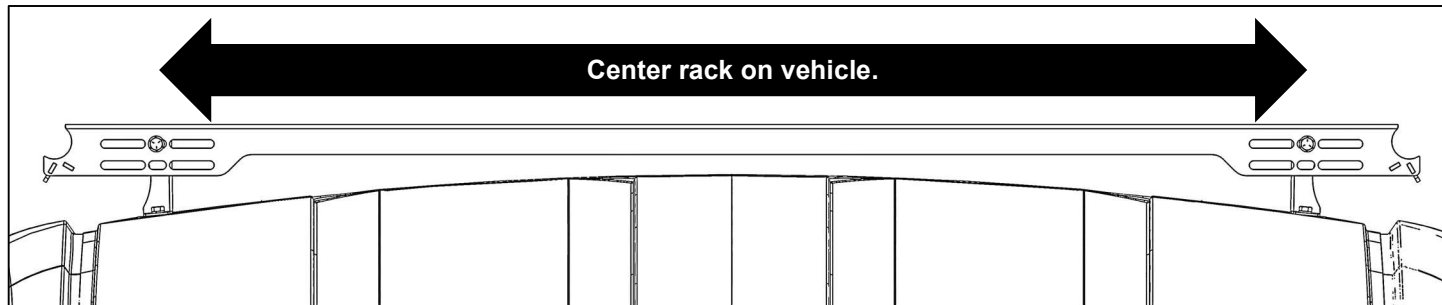

- Using 3/8" x 1" hex head bolts, 3/8" lock nuts, and 3/8" flat washers provided with mounting kit, bolt crossbar to feet.
- Tighten but allow movement.

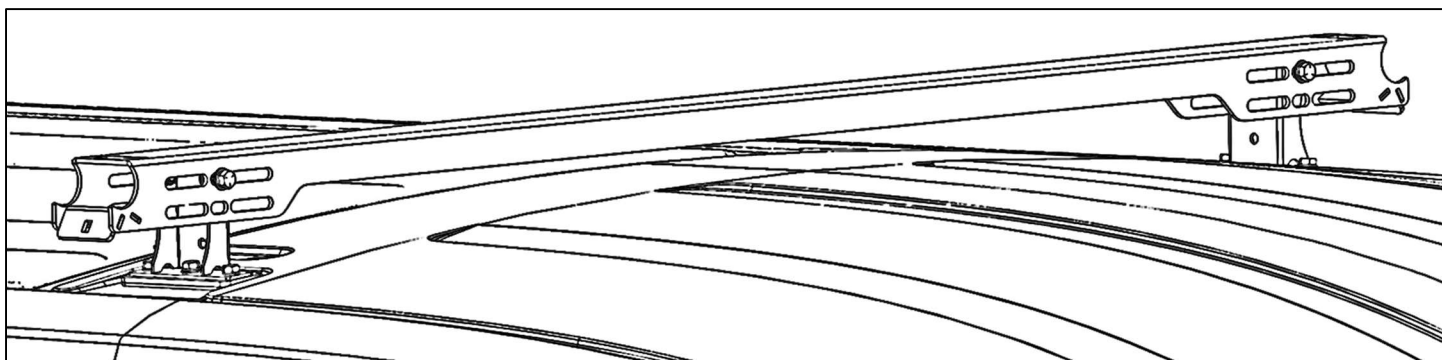
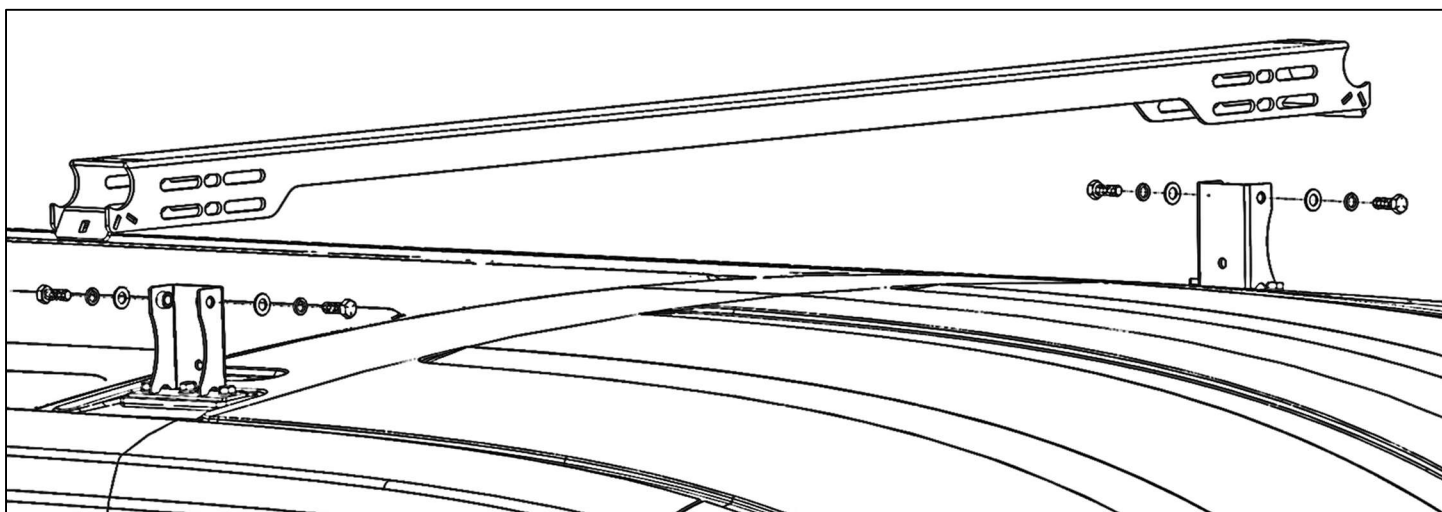

- Repeat for all remaining crossbars.

## Step 4 – Attach Side Channels to Crossbars

- Set side channel into round cutout in crossbars in desired position.
- Although rack position may be adjusted later, it is recommended to determine the front-to-back position of the rack at this point.
- Insert a side channel clamp into cutout in each crossbar with interior diameter facing upward.

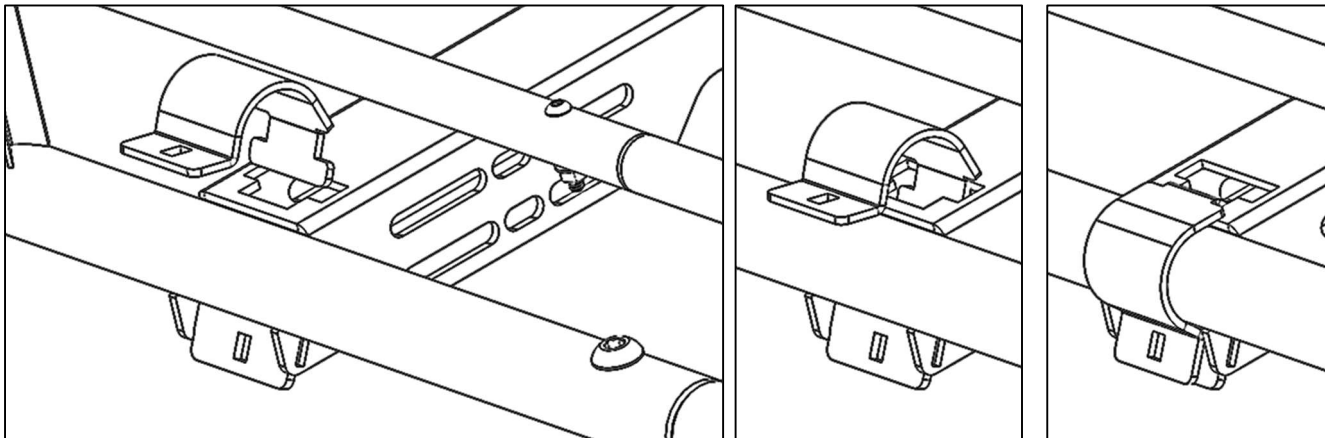

- For each side channel clamp, use a 5/16" x 1" carriage bolt and 5/16" flanged lock nut to bolt side channel clamp to crossbar.
- Snug Tight but allow for movement.

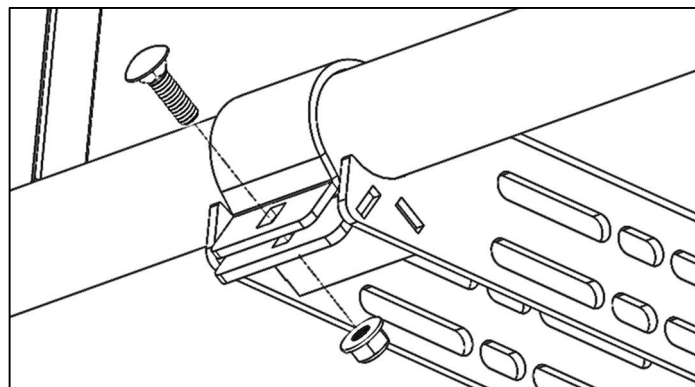

## Step 5 – Attach Front Crossbar

- Cover swage joints with sealant per Sealant Application guidelines. Push front crossbar onto swaged end of side channel. **Be sure to align holes in both and be sure flat face of wind deflector is on top.**
- Using a 1/2" x 2-1/2" button head cap screw, 1/2" flat washer, and 1/2" locking jam nut, bolt through front of side channel and front crossbar.
- Tighten.
- Repeat for opposite side.

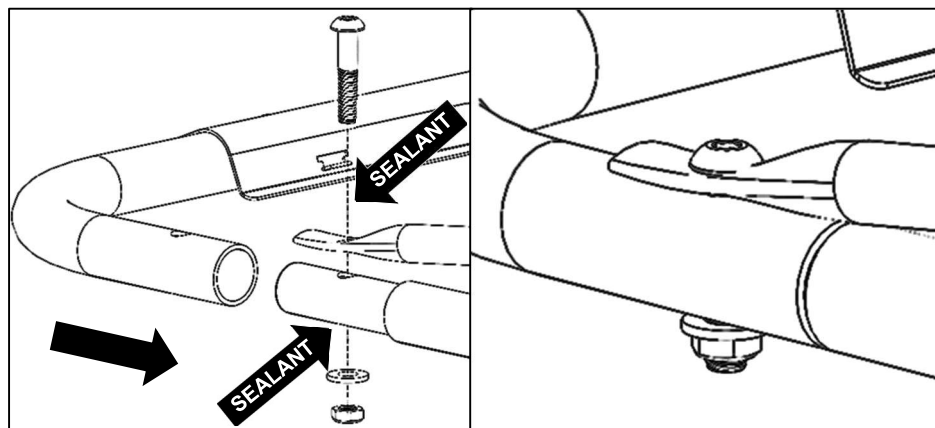



## **Step 6 – Attach Roller Bar Assembly**

- Using a 1/4" x 1" hex head bolt, 1/4" lock washer, and 1/4" flat washer, bolt through the TOP hole in the roller bar bracket into end of TOP of side channel.
- Using a 5/16" x 1-1/4" hex head bolt, 5/16" lock washer, and 5/16" flat washer, bolt through the BOTTOM holes in the roller bar bracket into end of BOTTOM of side channel.
- LOOSELY tighten hardware.
- Repeat for opposite side.
- **Check that the rack is square to the vehicle and mounts.**

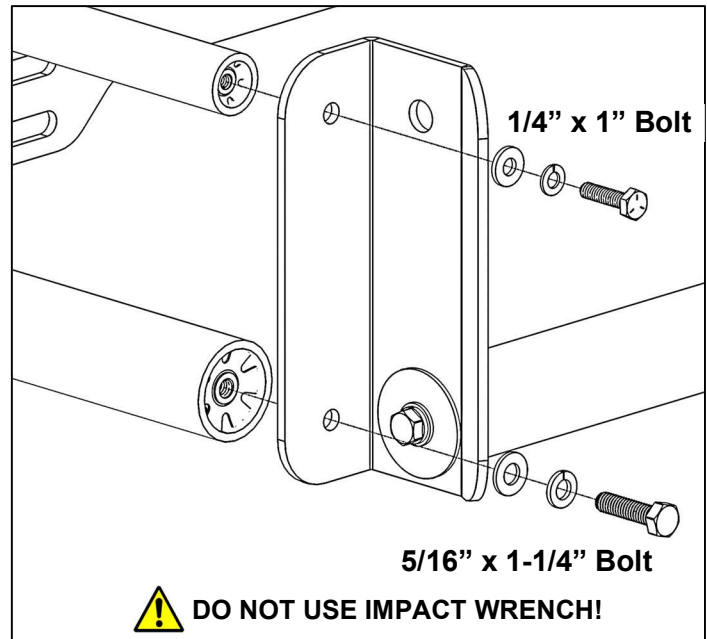

- **Be sure the rear roller bar is hanging off the rear of the vehicle enough so that when placing a ladder on the rack, it does not come into contact with the rear of the vehicle.**

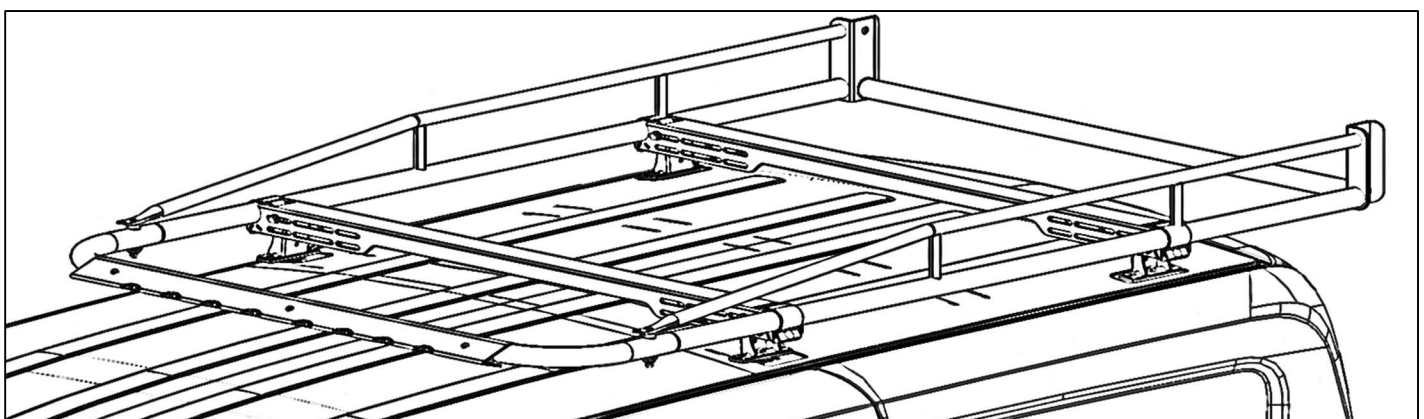
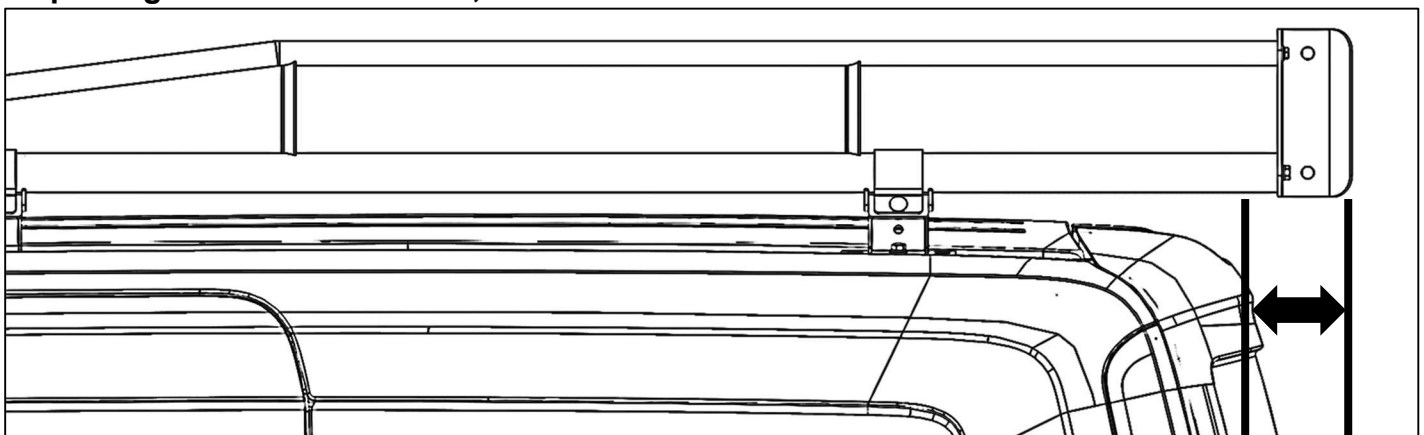

**GO BACK AND TIGHTEN ALL HARDWARE.**

**INSTALLATION AND ASSEMBLY ARE COMPLETE.**