

Holman

Instruction Guide 48301NC

* Shelf not included.

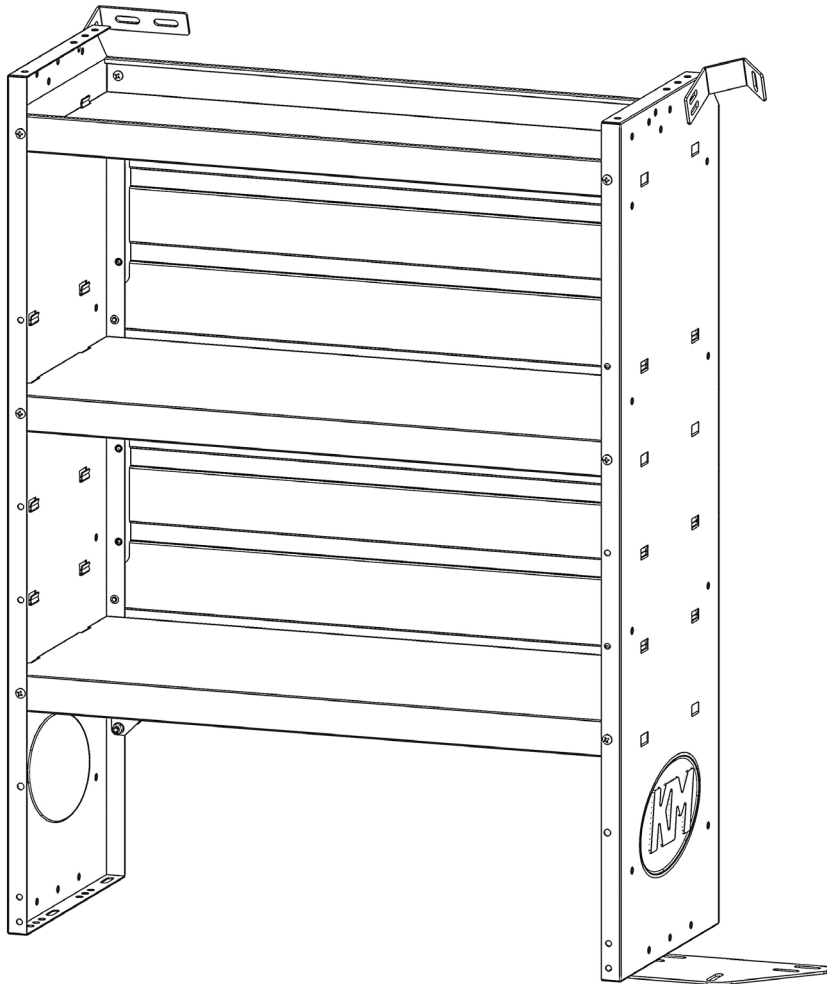

Holman
Rancho Cordova, CA 95742
800-343-7486
InstallationSupport@holman.com

PLEASE READ ALL INSTRUCTIONS AND WARNINGS PRIOR TO ASSEMBLING, INSTALLING, AND USING THIS PRODUCT.

Warning



Always check for wires, fuel tanks and lines, brake lines and other important vehicle functionality items prior to drilling and installing all products.

Tools Needed

7/16", 1/2", 9/16" Sockets and Wrench	10mm Socket and Wrench
7/16" Box Wrench	

Table of Contents

Before You Begin.....	1
Parts List.....	2
Hardware	2
Step 1 – Install Bracket to Shelf	4
Step 2 – Install Shelf to Floor	4
Step 3 – Install Rear Door Mount Bracket	5
Step 4 – Install L-Mounting Bracket.....	6



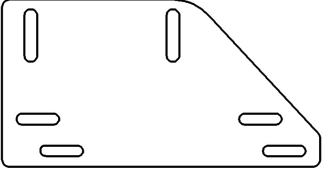
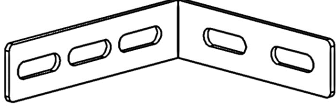
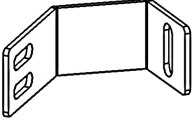

Before You Begin

- Read all instructions prior to installing any Kargo Master product.
- Ensure it is safe to drill before drilling anywhere on vehicle.
- Instructions shown using a 43”H x 32”W shelf. Instructions are the same for the 26”W shelf.
- Be sure to have assembled shelf prior to beginning these instructions.
- **When installing, LIFT shelf into position, DO NOT DRAG shelf to position.**

Parts List

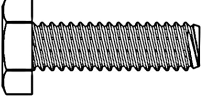
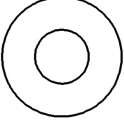
ITEM NO.	ITEM	PART NUMBER	DESCRIPTION	QTY
1		4016L-43-001	BASE PLATE BRACKET	1
2		4016T-10-005	L MOUNTING BRACKET	1
3		4016L-43-006	UPPER REAR BRACKET	1
4		18-48301NV	48301NC HARDWARE KIT	1

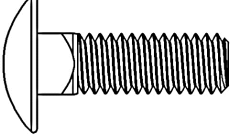
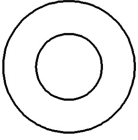
Hardware

ITEM	HARDWARE TO SCALE	PART NUMBER	DESCRIPTION	QTY.
1		13004	1/4"-20 X 7/8" HEX HEAD BOLT	2
2		33078	1/4" FLAT WASHER	4
3		37018	1/4"-20 NYLON INSERT LOCK NUT	2
4		21811	5/16-18 X 1" CARRIAGE BOLT	1
5		11545144	5/16" FLAT WASHER	1
6		0169777	5/16"-18 NYLOC	1

Hardware (Continued)

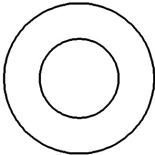
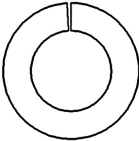
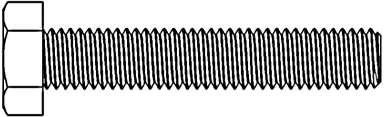
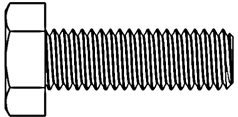
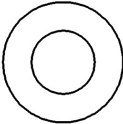
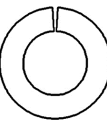
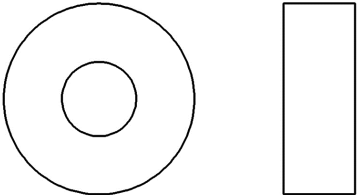
ITEM	HARDWARE TO SCALE	PART NUMBER	DESCRIPTION	QTY.
7		11552366	M10 FLAT WASHER	1
8		ML6400000ZY0000	M10 SPLIT LOCK WASHER	1
9			M8 X 1.25 X 45MM HEX HEAD, FULLY THREADED	1
10		0162378	M8-1.25 X 25MM HEXHEAD BOLT	2
11		40357	M8 FLAT WASHER	3
12		ML6380000ZY0000	M8 LOCKING WASHER	3
13		11517442	3/8" ID 1" OD NYLON SPACER	4

Step 1 – Install Bracket to Shelf

- Using one 5/16" x 3/4" carriage bolt, one 5/16" flat washer, and one 5/16" lock nut, install the base plate brackets to the bottom of the shelf per the following diagrams.
- Snug tighten but allow movement.

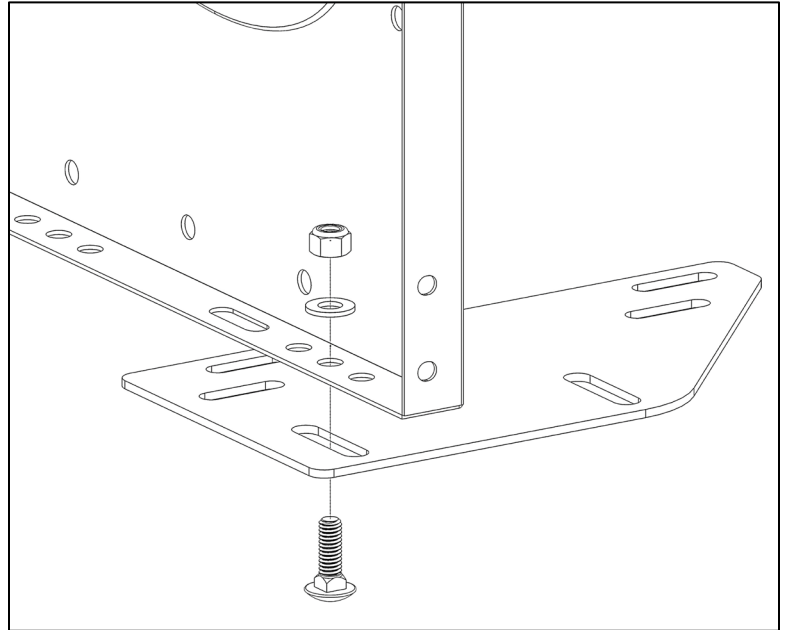

Step 2 – Install Shelf to Floor

- Remove D-rings from threaded bosses installed on the floor to the front of and rear of the wheel well.
- DO NOT DRAG shelf into position. Lift shelf and set into position with hole in bottom of shelf aligned with threaded boss.
- Using the factory bolt removed from the D-ring, one M10 lock washer, one M10 flat washer, and if necessary, one 3/8" nylon floor spacer, bolt the left side of shelf to the threaded bosses in the floor. Be sure to bolt through the 3/8" nylon floor spacer between shelf and floor, if a gap exists between shelf and floor.
- Snug tighten but allow movement.

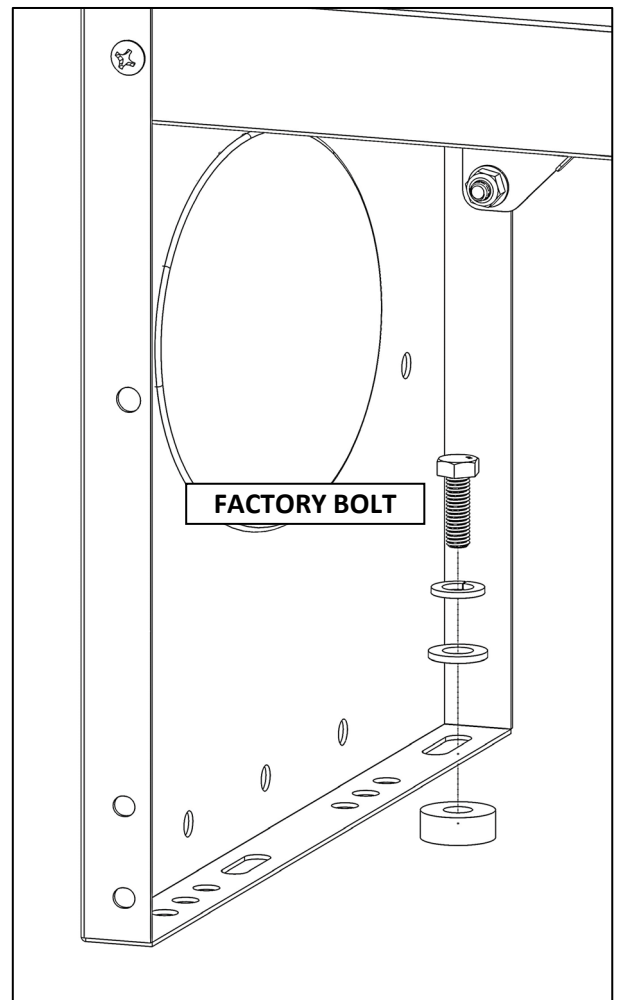

- Using one M8 x 45mm bolt, one M8 lock washer, one M8 flat washer, and three 3/8" nylon floor spacers, bolt the shelf to the threaded bosses in the floor. Be sure to bolt through the 3/8" nylon floor spacers between shelf and floor. This stabilizes the rear of the shelf.
- Snug tighten, but allow movement.

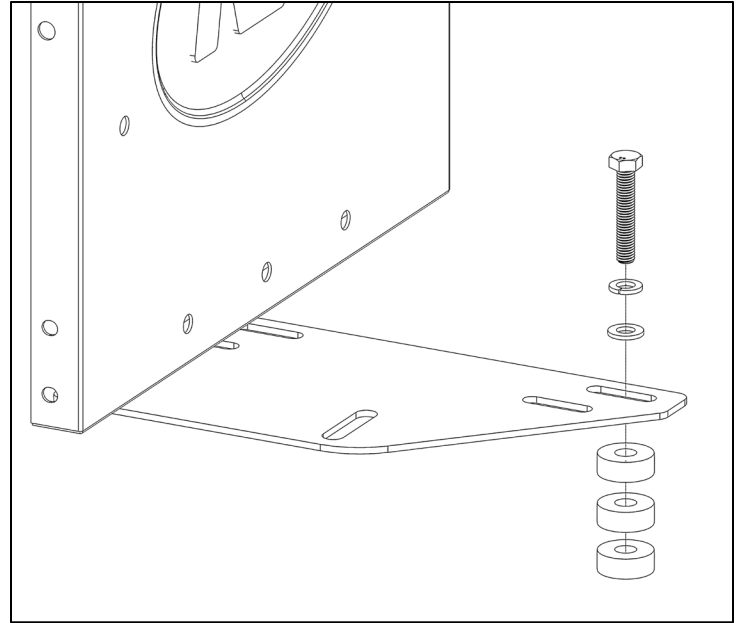

Step 3 – Install Rear Door Mount Bracket

- Place the door mount bracket against the rear van pillar.
- Align one of the holes in the door mount bracket to the factory weld nut in the rear van pillar. If installing a 46" shelf as shown, install to upper weld nut in rear door pillar. If installing a 43" shelf, use the next weld nut down.
- Using one M8 x 25mm hex bolt, one M8 lock washer, and one M8 flat washer, LOOSELY bolt the door mount bracket to the weld nut.
- Snug tighten but allow movement.

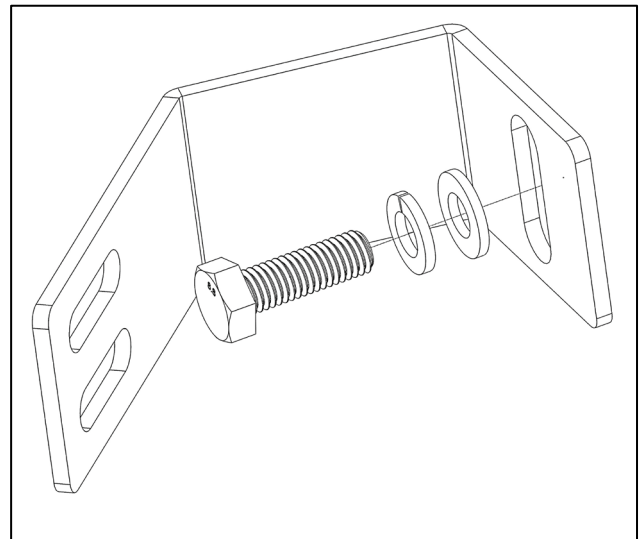

- Using one 1/4" x 7/8" bolt, two 1/4" flat washers, and one 1/4" lock nut, bolt the door mount bracket to a hole in the shelf side.
- Snug tighten but allow movement.

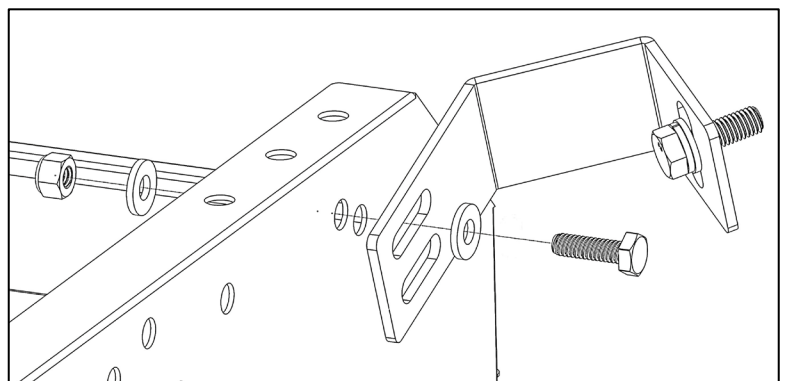

Step 4 – Install L-Mounting Bracket

- Place and hold the L-mounting bracket in a position at the rear of the shelf so one of the slots in the L-mounting bracket aligns with a hole in the shelf and hole in the flange aligns with factory weld nut the van side door pillar.
 - Using one 1/4" x 7/8" bolt, two 1/4" flat washers, and one 1/4" lock nut, LOOSELY bolt the L-mounting bracket to the shelf unit.
-
- Using one M8 x 25mm hex bolt, one M8 lock washer, and one M8 flat washer, bolt the L-mounting bracket to the factory weld nut in side door pillar. The picture shows a 46" high shelf installation.
 - Level and align shelf.
 - Tighten all hardware.

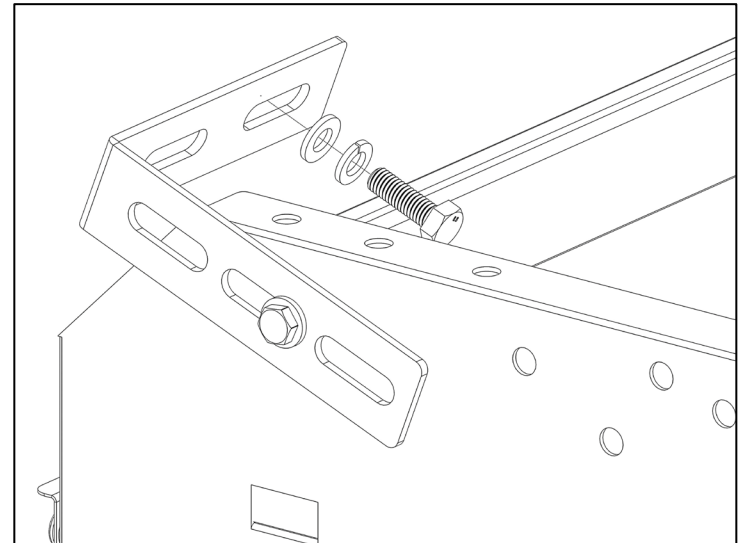
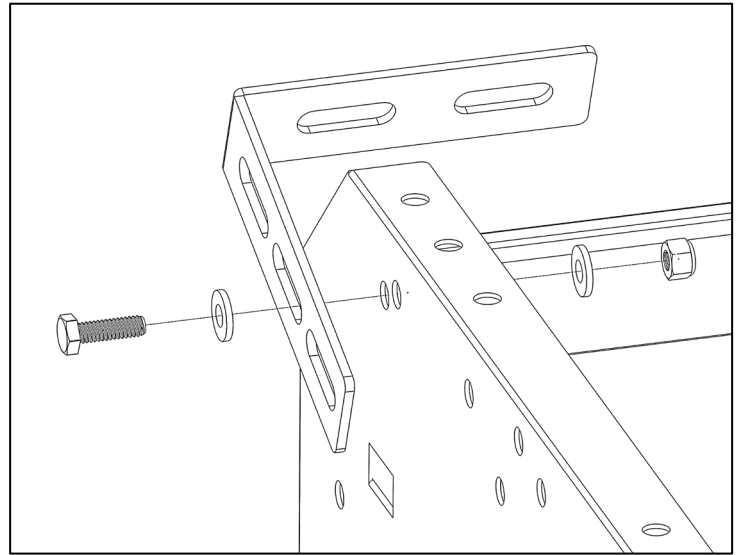

GO BACK AND ENSURE ALL HARDWARE IS TIGHTENED.

INSTALLATION IS COMPLETE.