

Holman

Instruction Guide 48009



Holman
Rancho Cordova, CA 95742
800-343-7486
InstallationSupport@Holman.com

PLEASE READ ALL INSTRUCTIONS AND WARNINGS PRIOR TO ASSEMBLING, INSTALLING, AND USING THIS PRODUCT.

Warning



Always check for wires, fuel tanks and lines, brake lines and other important vehicle functionality items prior to drilling and installing all products.

Table of Contents

Tools Needed 1

Before You Begin 1

Parts List..... 2

Hardware 2

Step 1 – Measure and Mark Mount Locations 3

Step 2 – Install Plus Nuts..... 3

Step 3 – Install First Strut Channel 4

Step 4 – Install Backing Plates 4

Step 5 – Install Second Strut Channel 5

Step 6 – Install Second Strut Channel 5

Step 7 – Install Folding Shelves to Strut Channel..... 5

Tools Needed

7/16" Socket and Wrench	1/2" Socket and Wrench
25/64" Drill Bit	Drill
Plus Nut Installation Tool (P9902)*	

** Sold Separately.*

Before You Begin

- Read all instructions prior to assembling or installing any Holman product.
- **Always locate your installation locations prior to performing any work.**
- **ENSURE SAFETY WHILE INSTALLING OR DRILLING INTO VEHICLE.**
- **Plus Nut Installation Tool Kit (P9902) is not included and must be purchased separately.**
- **This kit can be used in various wall mounting applications, this document will focus on the folding shelves.**
- **Please make sure you have your folding shelf built prior to the installation of 48009.**

Parts List

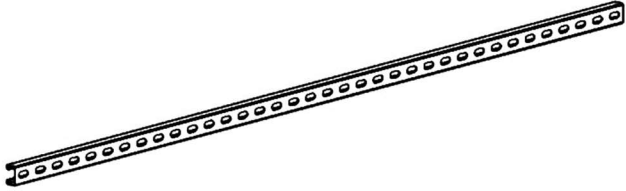
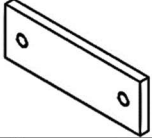
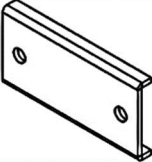
NO.	ITEM	PART NUMBER	DESCRIPTION	QTY.
1		3310T242	STRUT CHANNEL	2
2		48008-001	BACKING PLATE	6
3		48008-002	SPLICE PLATE	2
4		18-48009	48009 HARDWARE KIT	1

Hardware

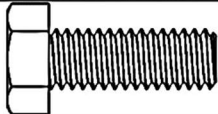
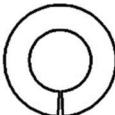
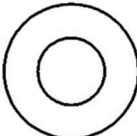
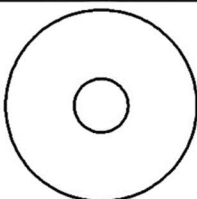
ITEM	HARDWARE TO SCALE	PART NUMBER	DESCRIPTION	QTY.
1		13054	5/16"-18 X 7/8" HEX HEAD BOLT	12
2		1171067	5/16" LOCKING WASHER	12
3		92141A030	5/16" FLAT WASHER	12
4		33207	1/4" OVERSIZED FLAT WASHER	8

Step 1 – Measure and Mark Mount Locations

- Measure your desired mounting length to determine how many Strut Channels needed for your installation.
- Measure the height off the floor needed for mounting the strut channel for your application. **Be sure to keep strut channel horizontal and square to the floor.**
- Determine the length needed for the first strut channel, trim if needed to get as many mounting locations as possible per strut channel.
- We recommend a minimum of four plus nuts per strut channel.
- **Be sure to align strut holes with a structural member of vehicle.**
- Mark locations for plus nuts.
- **Measure twice, drill and cut once.**

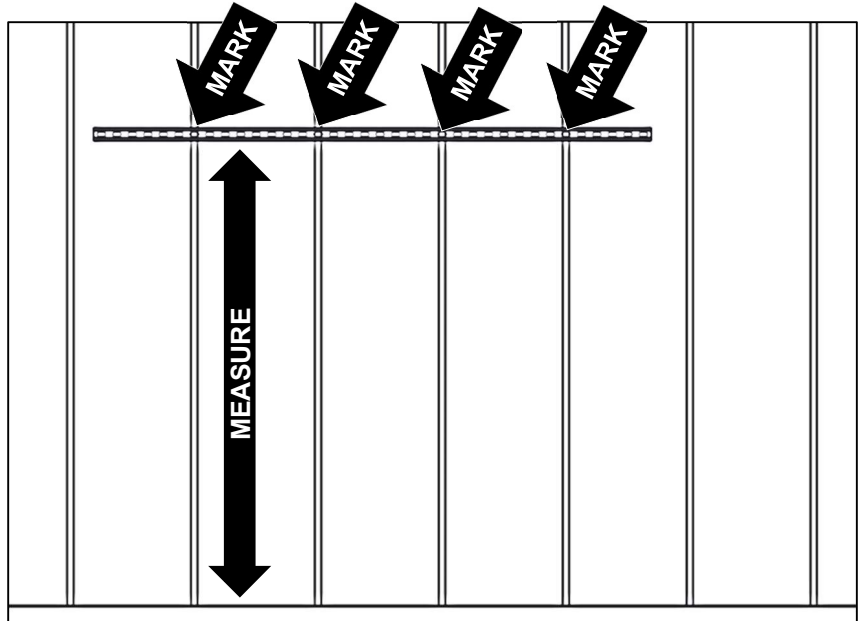

Step 2 – Install Plus Nuts



DO NOT drill beyond depth of floor or upper installation surface. Always check for wires, fuel tanks and lines, brake lines and other important vehicle functionality items prior to drilling and installing all products.

- Plus nuts are not included in the 48009 hardware kit. Use the plus nuts included with the folding shelves.
- At each marked location, drill hole using 25/64" drill bit and appropriate sized drill-bit stop collar. If 25/64" drill bit is not available, a 3/8" drill bit can be used, although it may be necessary to tap in the plus nuts.
- Insert 1/4" x 2-1/4" hex head bolt through 1/4" flat washer and plus nut installation tool, and then screw bolt into plus nut. Knurled end of plus nut tool must be directed away from bolt head and contacting plus nut.
- Insert plus nut into hole with plus nut tool attached.
- Using the 9/16" box wrench, hold the plus nut tool stationary and then tighten hex head bolt until plus nut is tightly gripping and does not spin when hex bolt is loosened.
- DO NOT overtighten plus nut.
- Using the 9/16" box wrench, hold the plus nut tool stationary to remove the 1/4" hex head bolt.

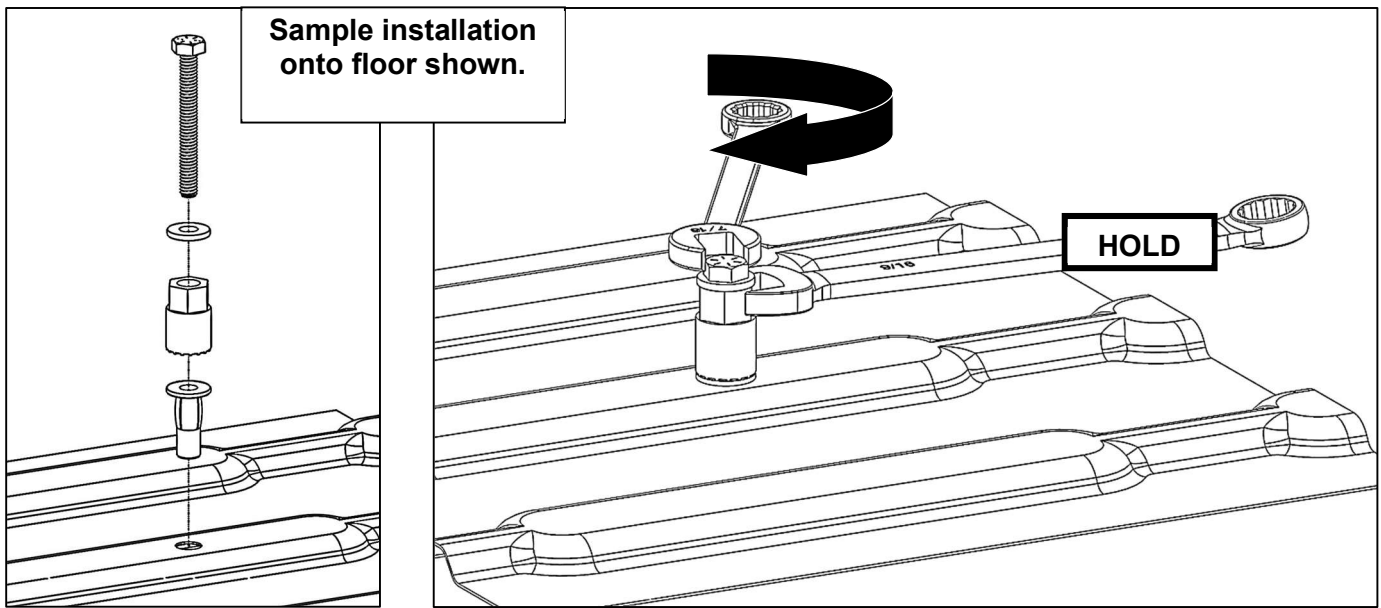

Step 3 – Install First Strut Channel

- Using 1/4"-20 X 1-1/4" hex head bolts (included with folding shelves), 1/4" lock washers (included with folding shelves), 1/4" oversized washers, bolt the first strut channel to the previously installed plus nuts in the orientation shown.

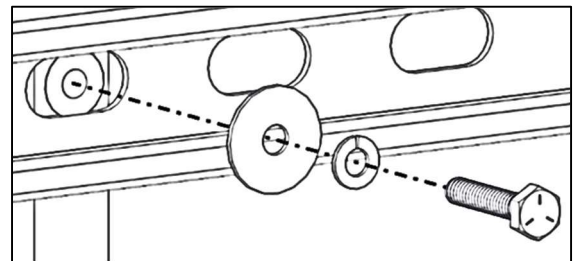

Step 4 – Install Backing Plates

- Determine the number of backing plates required for the number of mounting locations you need for your application, as well as one for the splice plate.
- Using desired number of backing plates, slide the plates into the exposed side of the strut channel.
- Be sure to slide backing plates into the strut channel before installing the splice plate.**
- Using two 5/16" X 7/8" hex head bolts, two 5/16 lock washers, and two 5/16" flat washers; attach splice plate to the last backing plate if attaching more strut channels together.
- Snug tighten but allow movement.

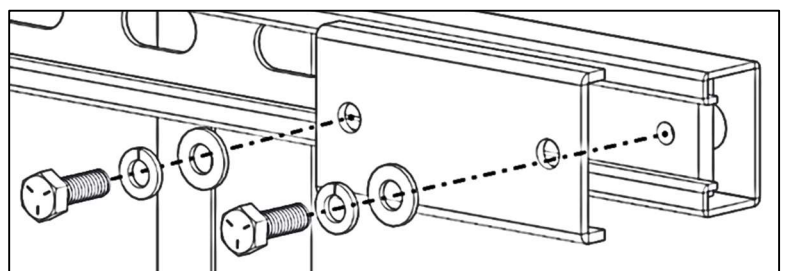
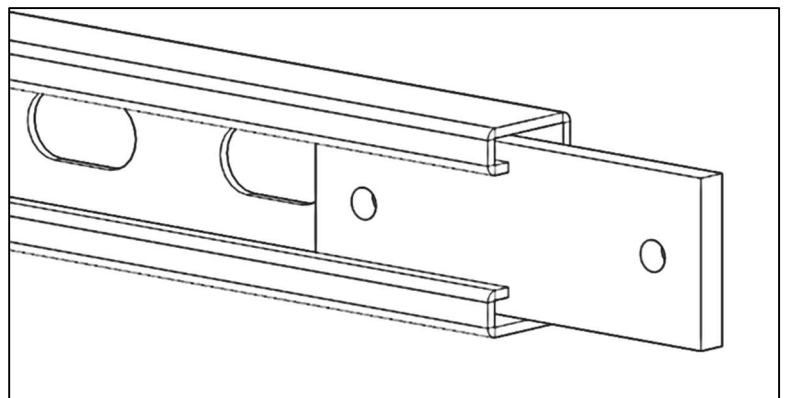

Step 5 – Install Second Strut Channel

- Align the next strut channel with the first, determine best mounting locations and required length. Trim if needed.
- Mark a minimum of four plus nuts per strut channel.
- **Be sure the second strut channel is horizontal and square to the floor and the installed strut channel.**
- **Be sure to align strut holes with a structural member of vehicle.**
- **Measure twice, drill once.**
- Install plus nuts following the process in step 2.
- Using 1/4"-20 X 1-1/4" hex head bolts (included with folding shelves), 1/4" lock washers (included with folding shelves), 1/4" oversized washers, bolt the first strut channel to the previously installed plus nuts in the orientation shown.

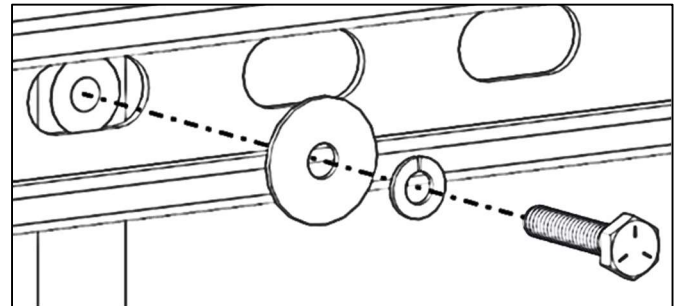
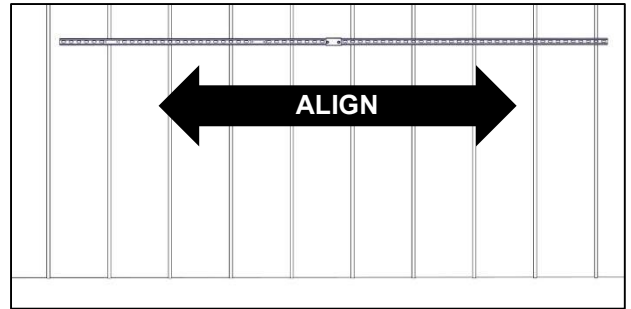

Step 6 – Install Second Strut Channel

- Attach First and second strut channels together using the pre-installed splice plate
- If installing an additional strut kit, follow the steps above.

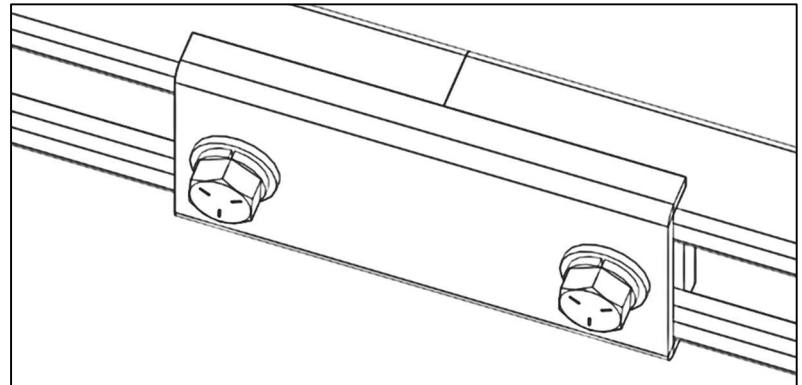

Step 7 – Install Folding Shelves to Strut Channel

- Slide backing plate to desired mounting location for your application.
- Using a backing plate, two 5/16" X 7/8" hex head bolts, two 5/16" locking washers and two 5/16" flat washers mounting foot to the backing plate.
- Repeat for opposite side.
- Mid mounts are not required for this installation, a second set of 48009 could be installed if desired.
- Complete install following equipment installation instructions for foot mounting.

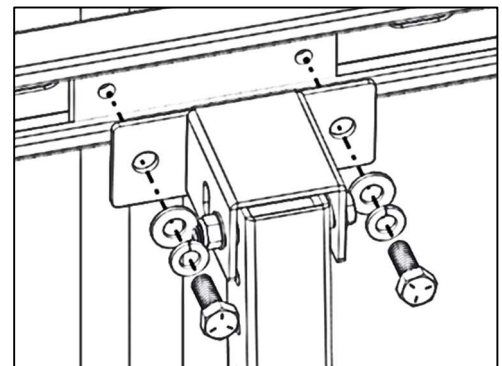

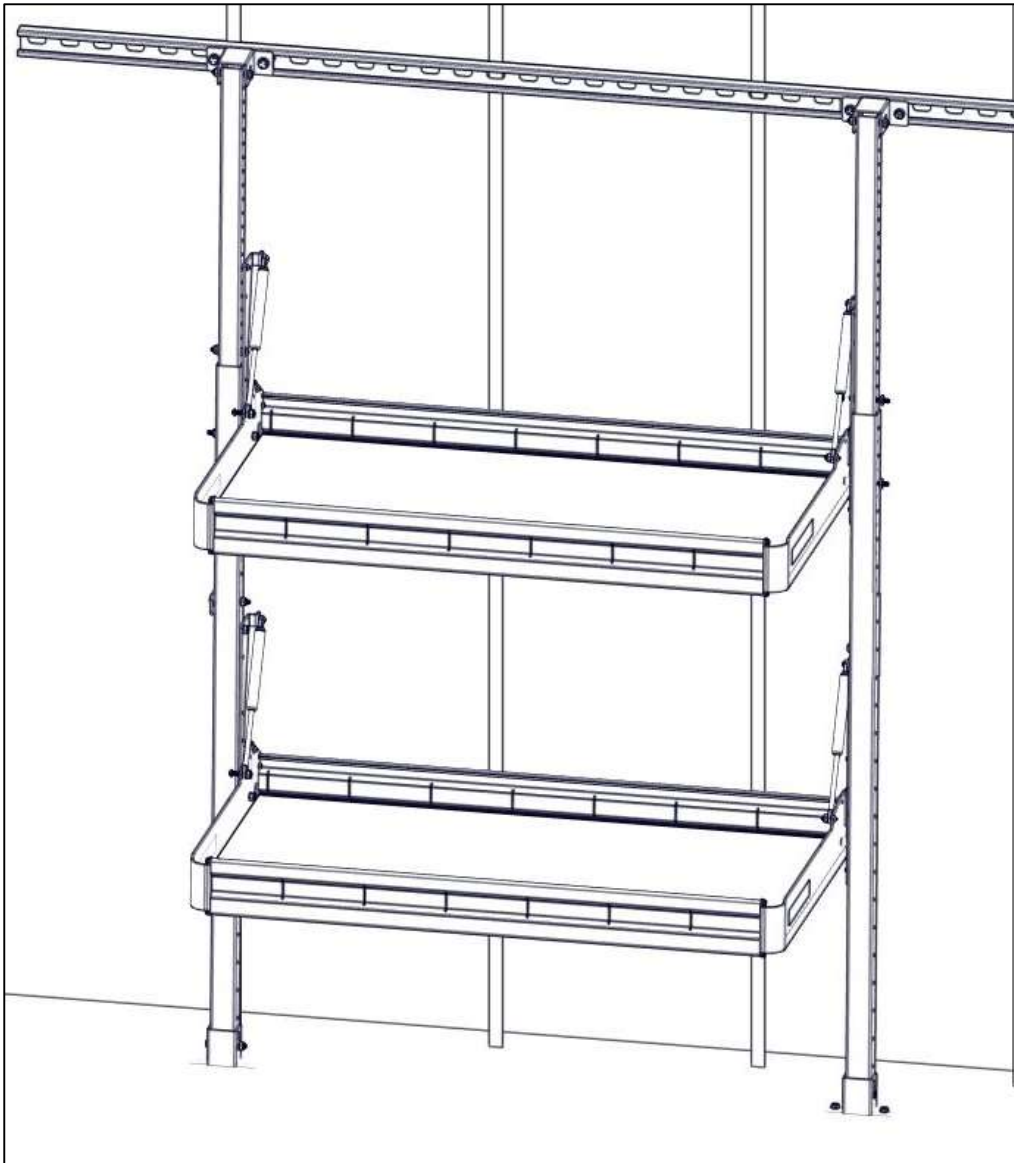

GO BACK AND TIGHTEN ALL HARDWARE.

INSTALLATION AND ASSEMBLY ARE COMPLETE.