

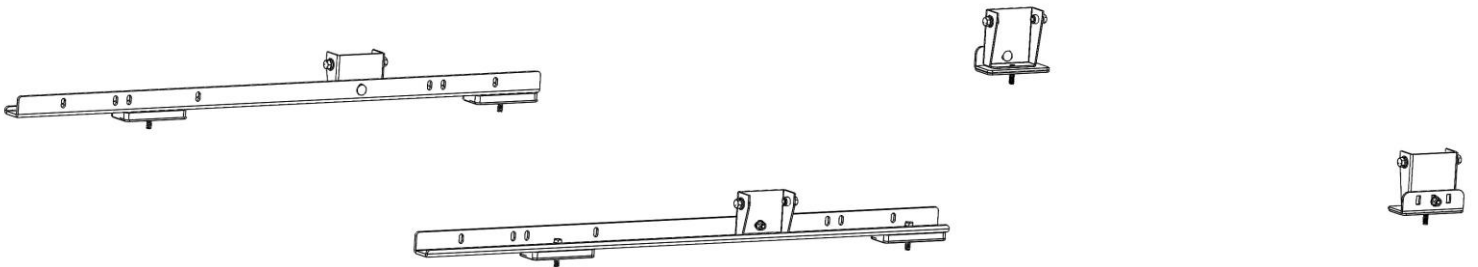

WE PUT EVERYTHING WITHIN REACH.

Installation Guide

408TC



Kargo Master
Rancho Cordova, CA 95742
800-343-7486
CustomerService@KargoMaster.com

PLEASE READ ALL INSTRUCTIONS AND WARNINGS PRIOR TO ASSEMBLING, INSTALLING, AND USING THIS PRODUCT

Warning



Always check for wires, fuel tanks and lines, brake lines and other important vehicle functionality items prior to drilling and installing all products.

Tools Needed

13mm Wrench and Socket	1/2" Wrench and Socket
5mm Allen Hex	9/16" Wrench and Socket

Table of Contents

Parts List 2

Hardware List 3

Ford Transit Installation

Step 1 – Rear Foot Mounting (exclude EXT) 4

130" Wheelbase

Step 2A – 130" WB Front Mount 5

148" Wheelbase

Step 2B – 148" WB Front Mount 7

EXT Installation

Step 3A – EXT Rear Foot Mounting 9

Step 3B – EXT Front Mount 10

Installation on Van



Step 4 – Installing Feet to Rack 11

Step 5 – Installing Rack to Van 12



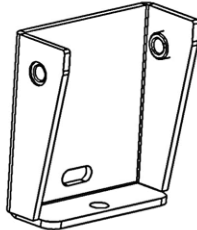
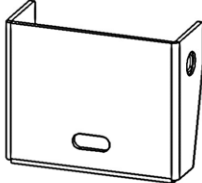

Before You Begin

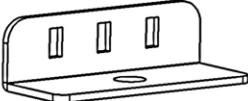
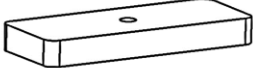
- Read ALL instructions prior to installing any Kargo Master product.
- Feet mount locations will vary based on size of van and rack type.
- **When installing on Ford Transit, be sure to put sealant around exposed threads in roof.**
- **Seal between the roof and the rubber pad.**
- **Put some on the threads of the bolt going into roof.**

Parts

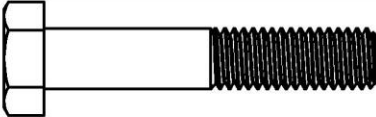
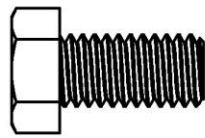
ITEM NO.	ITEM	PART NUMBER	DESCRIPTION	QTY.
1		40800-17	TALL FOOT	2
2		408TC-10	SHORT FOOT	2
3		4A901-10-001	FRONT RAIL	2
4		4A9ST-00-001	RR BRACKET	2
5		T249-01	T-249 PLATE	4
6		18-408TC	HARDWARE KIT	1

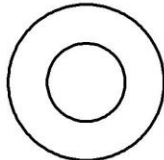
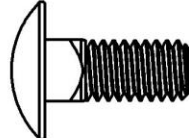
Hardware

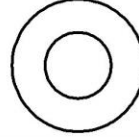
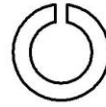
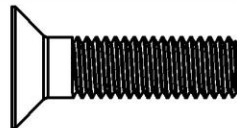
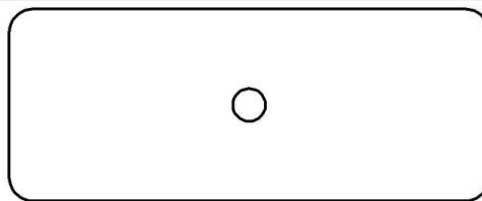
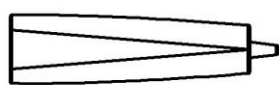
ITEM NO.	TO SCALE	PART NUMBER	DESCRIPTION	QTY.
1		95327A569	M8 x 45mm Hex Head	4
2		92865A622	3/8" x 3/4" Hex Head	8
3		91102A760	3/8" Split Lock Washer	8
4		90126A031	3/8" Flat Washer	8
5		90185A581	5/16"-18 x 3/4" Carriage Bolt	4
6		95615A160	5/16" Nyloc	4
7		90850A150	5/16" Flat Washer	8
8		91104A030	5/16" Split Lock Washer	4
9		91263A845	M8 x 30mm Flat Head	2
10		T249-02	EPDM Rubber 3MM Scale 1:2	6
11		BH-821	SEALANT	1

Ford Transit (EXCLUDING High Roof EXT)

Step 1 - Rear Foot Mounting

- Locate threaded emboss at rear of van. Plugs will need to be removed.

130" Wheel Base

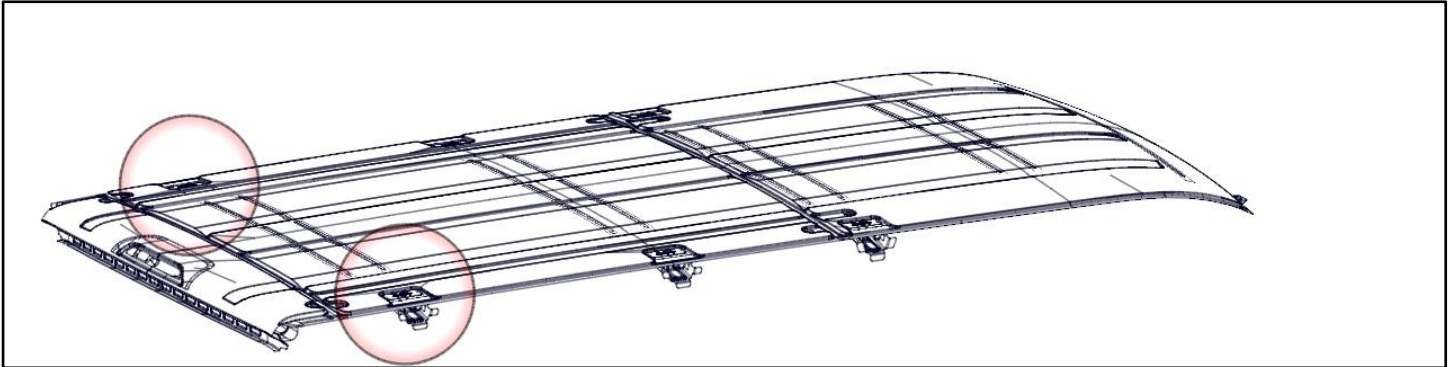

148" Wheel Base

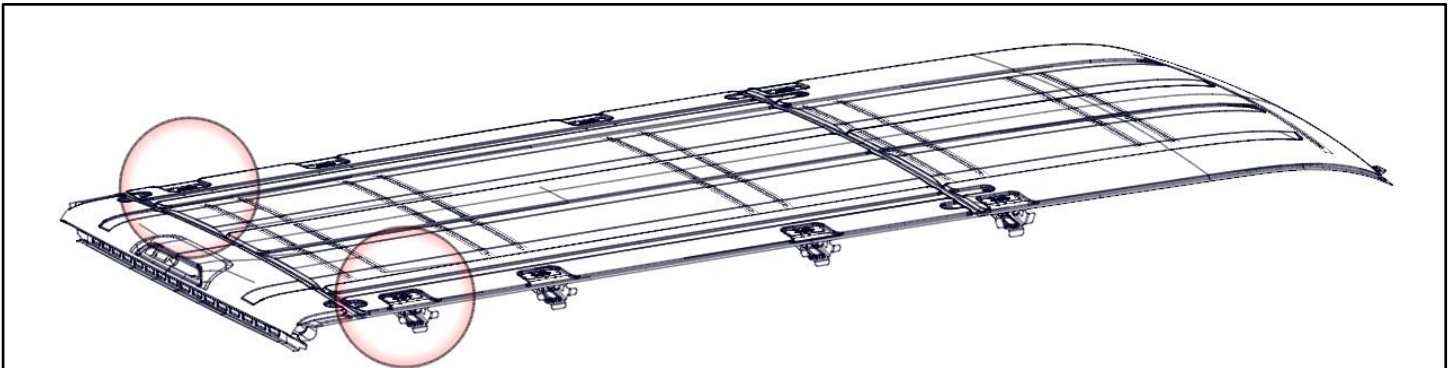

- Mount the rear mount bracket with M8 x 30mm Flat Head bolts. Place rubber pad between the bracket and the roof of the van. Place the bracket parallel with the length of the van.
- Have the flange on the bracket towards the outside of the van as shown.
- Passenger side shown, repeat on driver side.
- **Be sure to place sealant around the threads and under the rubber pad to ensure no water can leak into the cabin of the van.**
- Tighten.

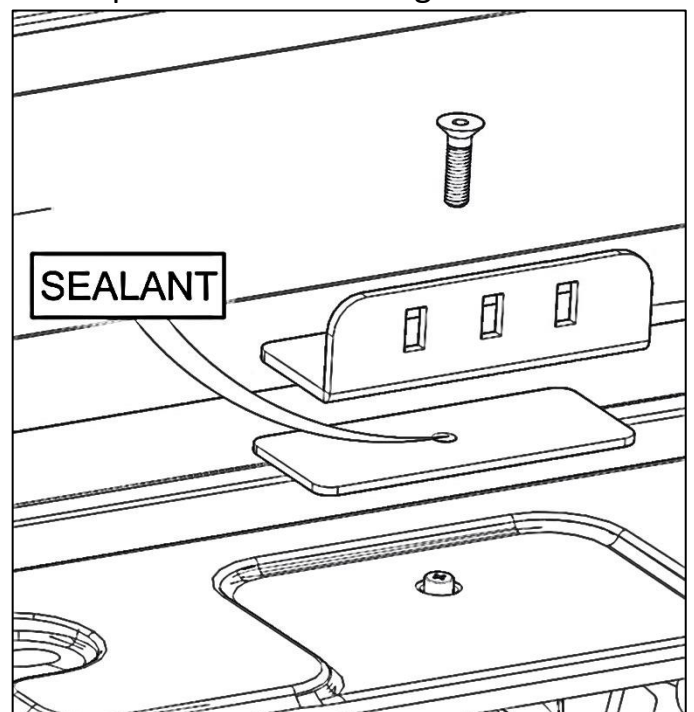
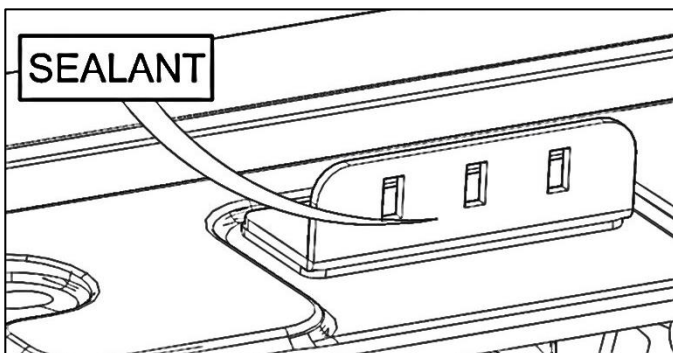

Step 2A – Front Mount on 130” WB (Low/Mid Roof)

- Locate the other threaded emboss at the front of van. Plugs will need to be removed.

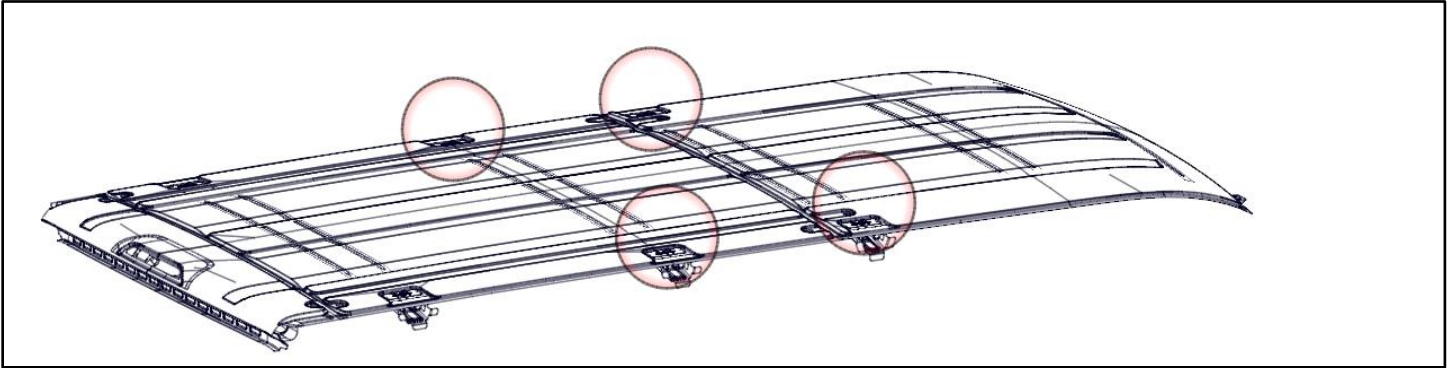

- Place the long mount rail with the tall flange to the center of the van.
- Bolt through the farthest rear slot and the corresponding front slot in the rail using M8 x 45mm bolts with lock washers and flat washers.
- The rail should be offset to the front of the van.
- The picture shown here is the rear most mount on the rail.
- **Be sure to place sealant around the threads and under the rubber pad to ensure no water can leak into the cabin of the van.**

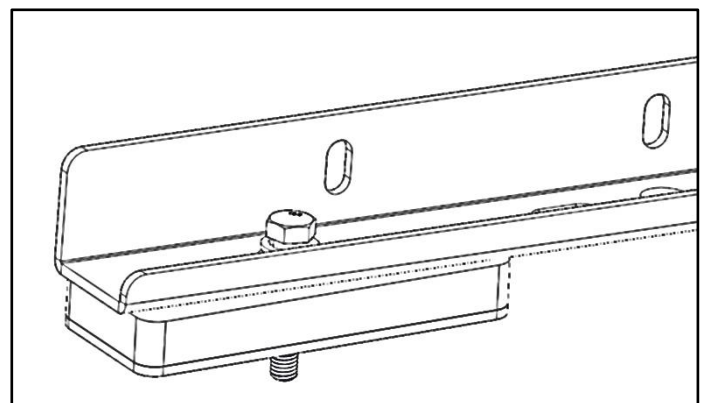
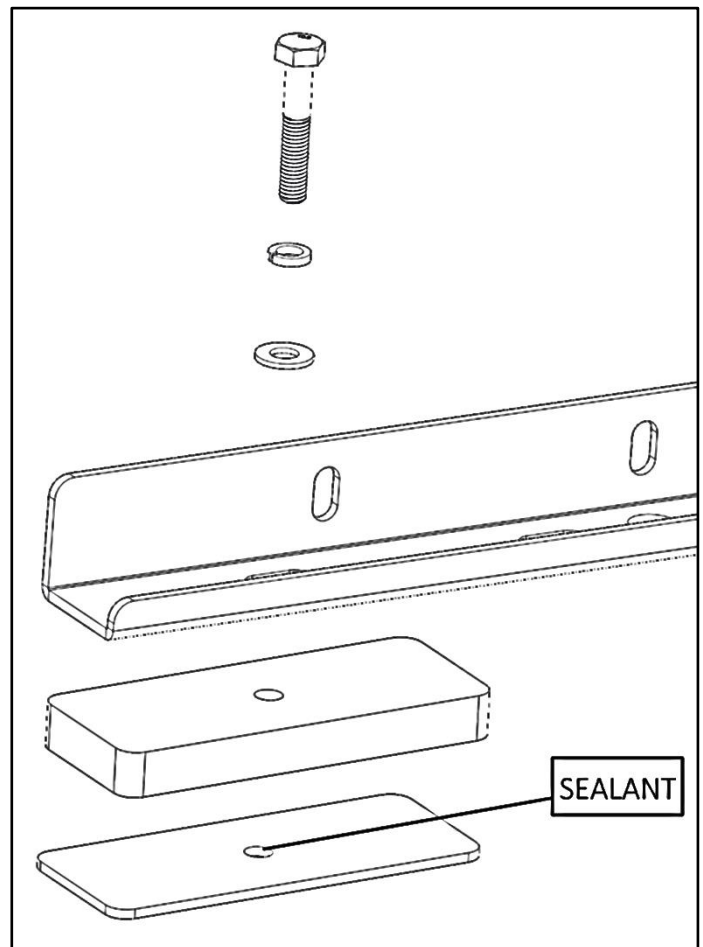

- Passenger side shown, repeat on driver side.
- Snug tighten.

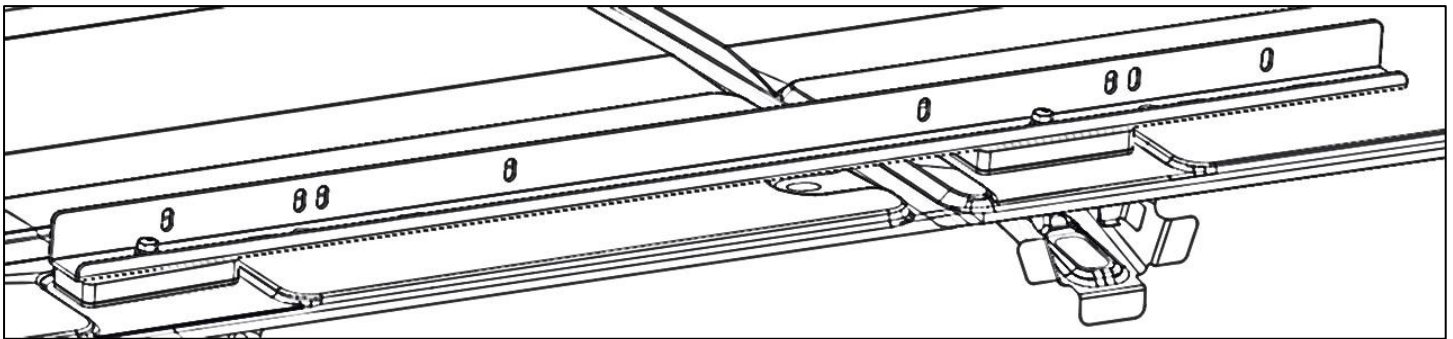
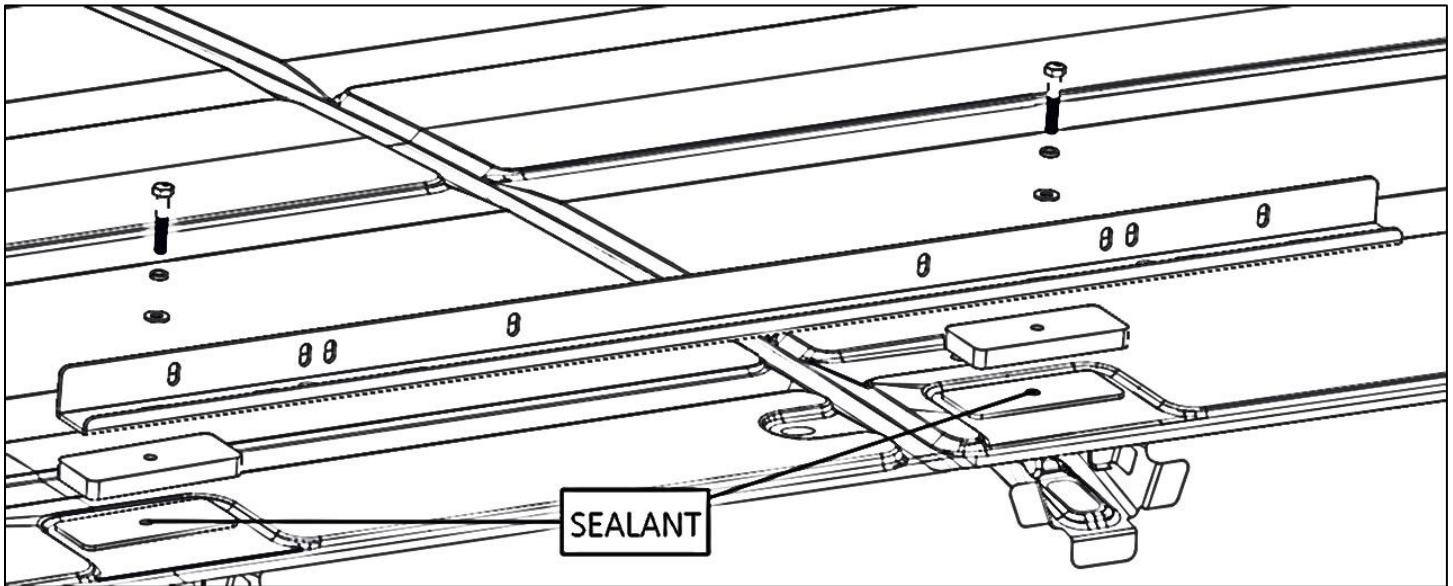

Step 2B – Front Mount on 148” WB (Low/Mid/High Roof exclude EXT)

- Locate the other threaded emboss at front of van. Plugs will need to be removed.

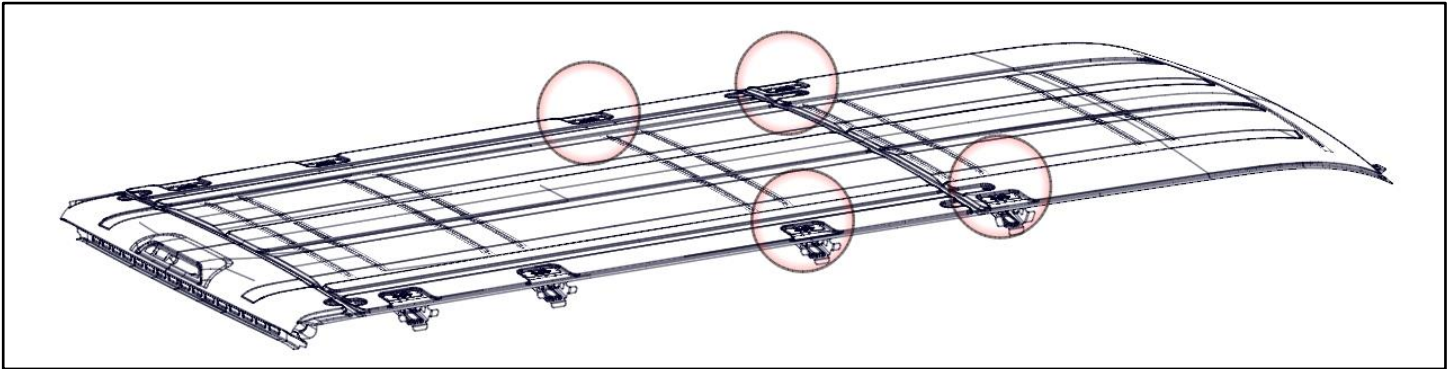

- Place the long mount rail with the tall flange to the center of the van.
- Bolt through the farthest rear slot and the corresponding front slot in the rail using M8 x 45mm bolts with lock washers and flat washers.
- The rail should be offset to the front of the van.
- The picture shown here is the rear most mount on the rail.
- **Be sure to place sealant around the threads and under the rubber pad to ensure no water can leak into the cabin of the van.**

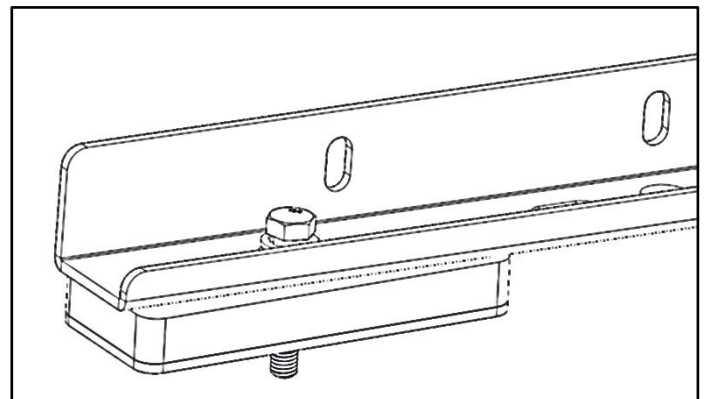
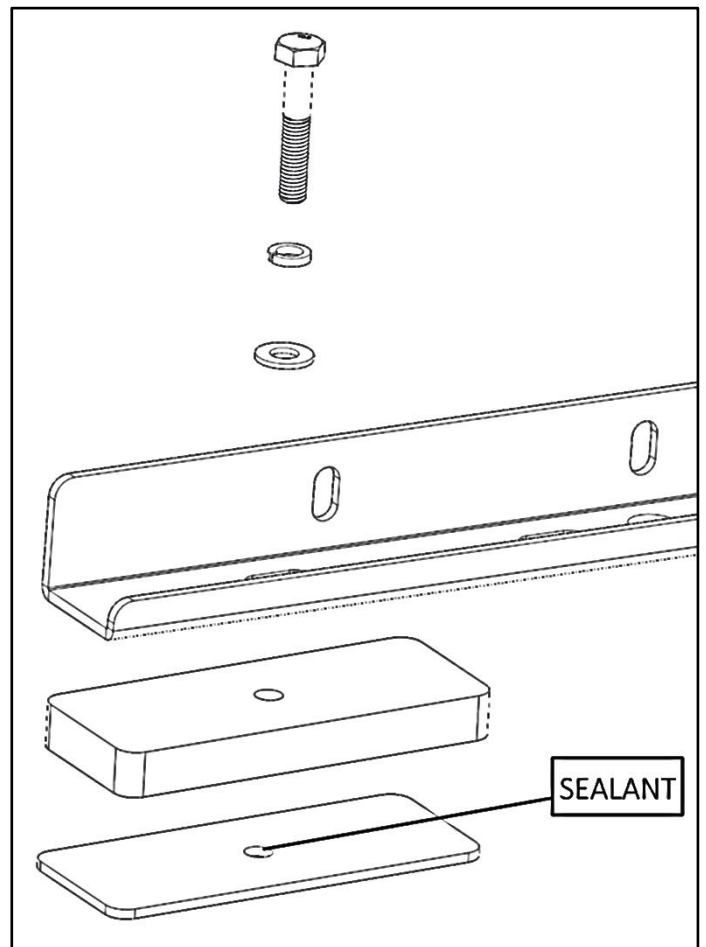

- Passenger side shown, repeat on driver side.
- Snug tighten.

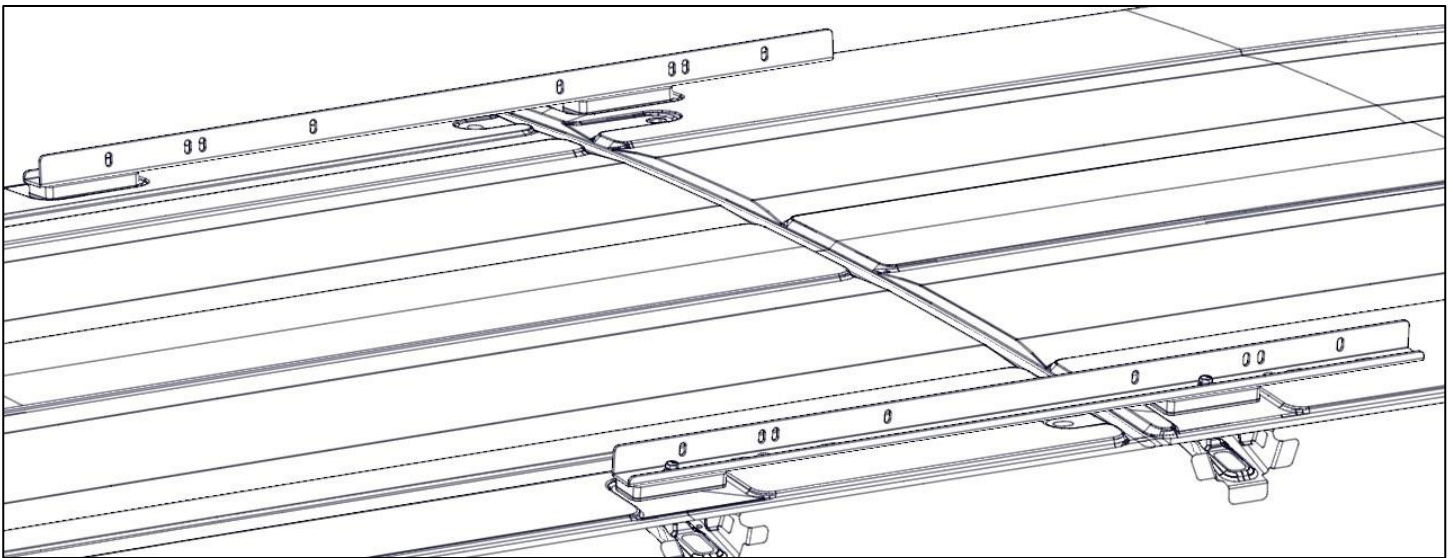
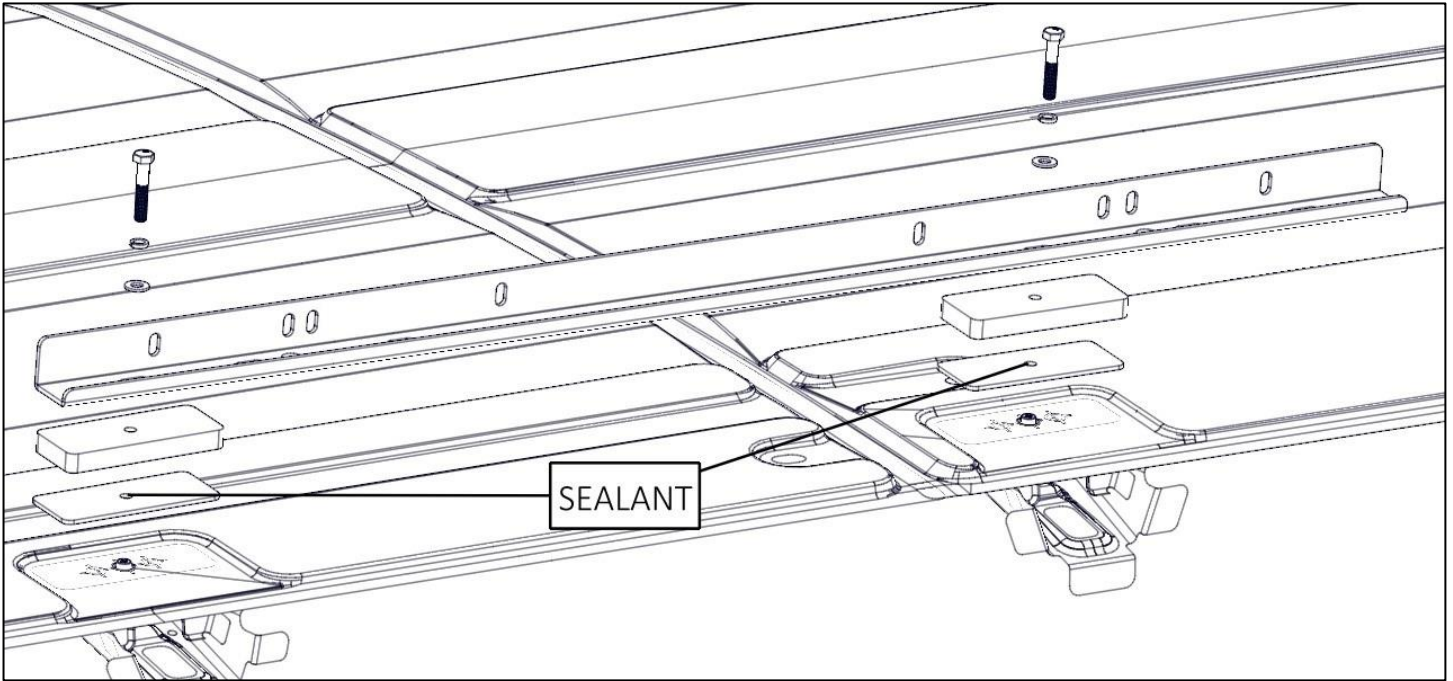

Transit 148" Wheelbase, High Roof, EXT

Step 3A – EXT Rear Foot Mounting

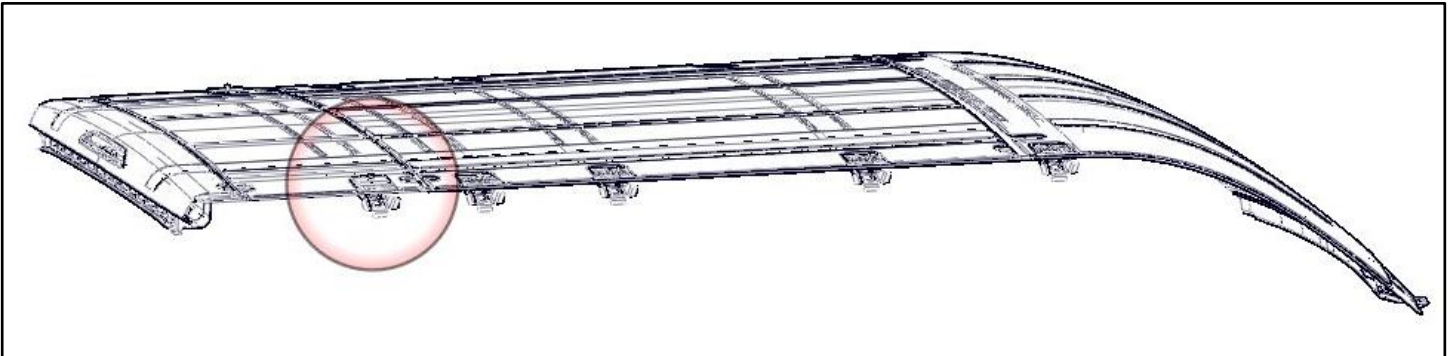

- Mount the rear mount bracket with M8 x 30mm flat head bolts. Place rubber pad between the bracket and the roof of the van. Place the bracket parallel with the length of the van.
- Have the flange on the bracket towards the outside of the van as shown.
- Passenger side shown, repeat on driver side.
- **Be sure to place sealant around the threads and under the rubber pad to ensure no water can leak into the cabin of the van.**
- Tighten.

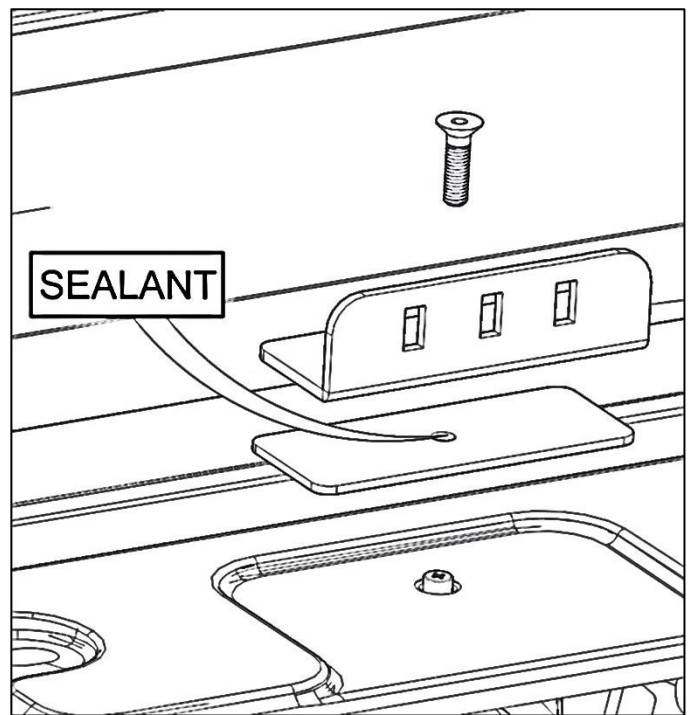
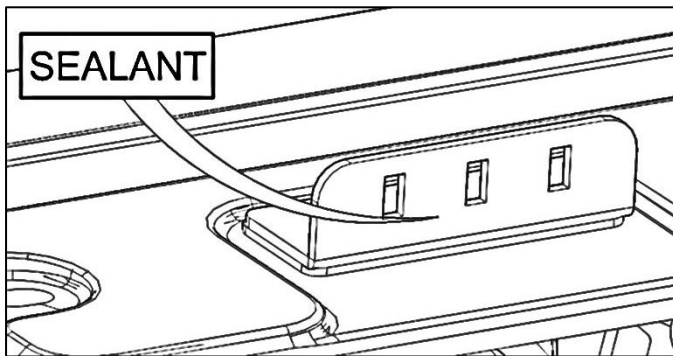

Step 3B – EXT Front Mount

- Locate other two threaded emboss at front of van. A plug will need to be removed.

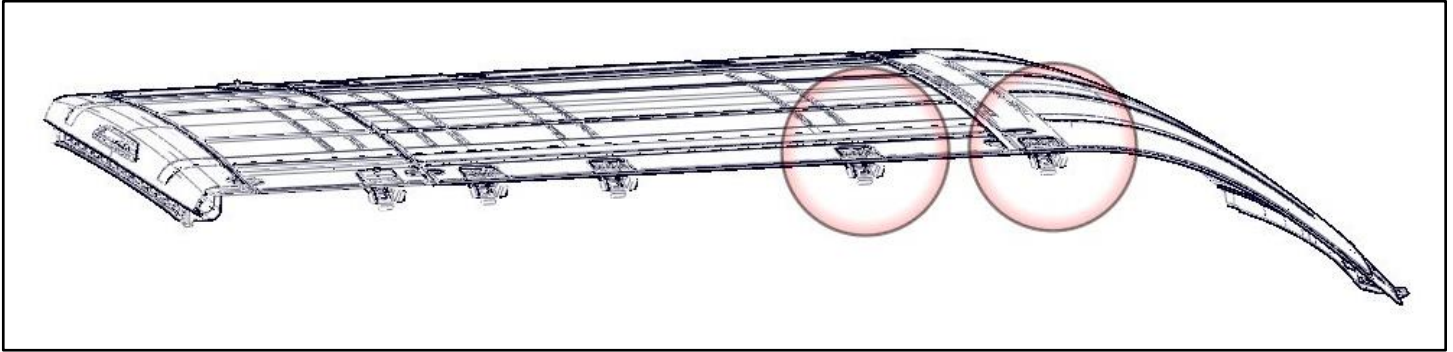

- Place the long mount rail with the tall flange to the center of the van.
- Bolt through the farthest rear countersunk hole and the 2nd slot from the front using M8 x 45mm bolts with lock washers and flat washers.

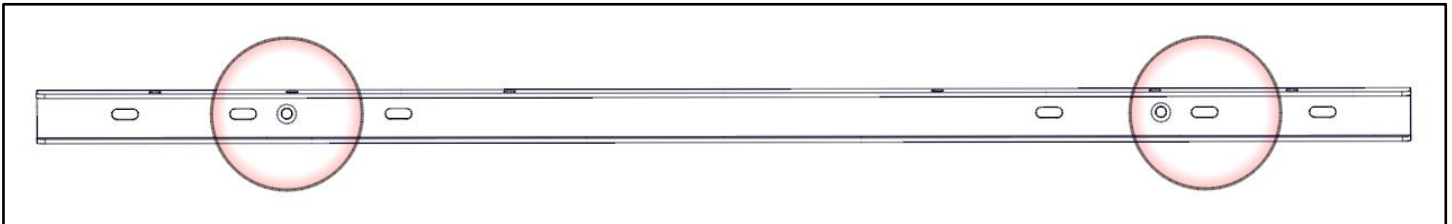

- The picture shown here is the rear most mount on the rail (through the countersunk hole).
- Passenger side shown, repeat on driver side.
- **Be sure to place sealant around the threads and under the rubber pad to ensure no water can leak into the cabin of the van.**
- Snug tighten.

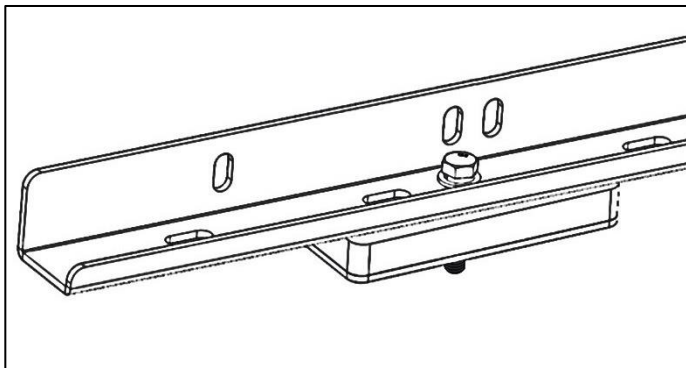
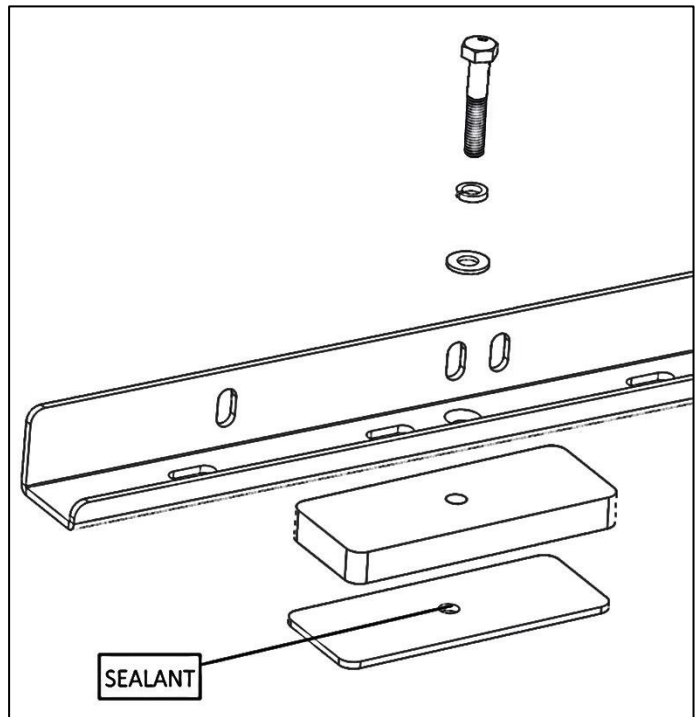

Step 4 – Installing Feet

- Have rack assembled.
- Measure width between the mounts on the van.
- On the cross bows, use the slots that correspond to the measured distance between rails.
- Bolt feet to bows as shown, DO NOT TIGHTEN at this point.
- Feet can be installed as shown or reverse depending on how you mounted the rail.
- Use a 3/8" x 3/4" hex head bolt, 3/8" lock washers and a 3/8" flat washer to bolt feet to crossmembers. Snug tighten, but allow movement.
- Design of feet may vary, but all mounting is the same.

The tall feet will be installed on the rear bow

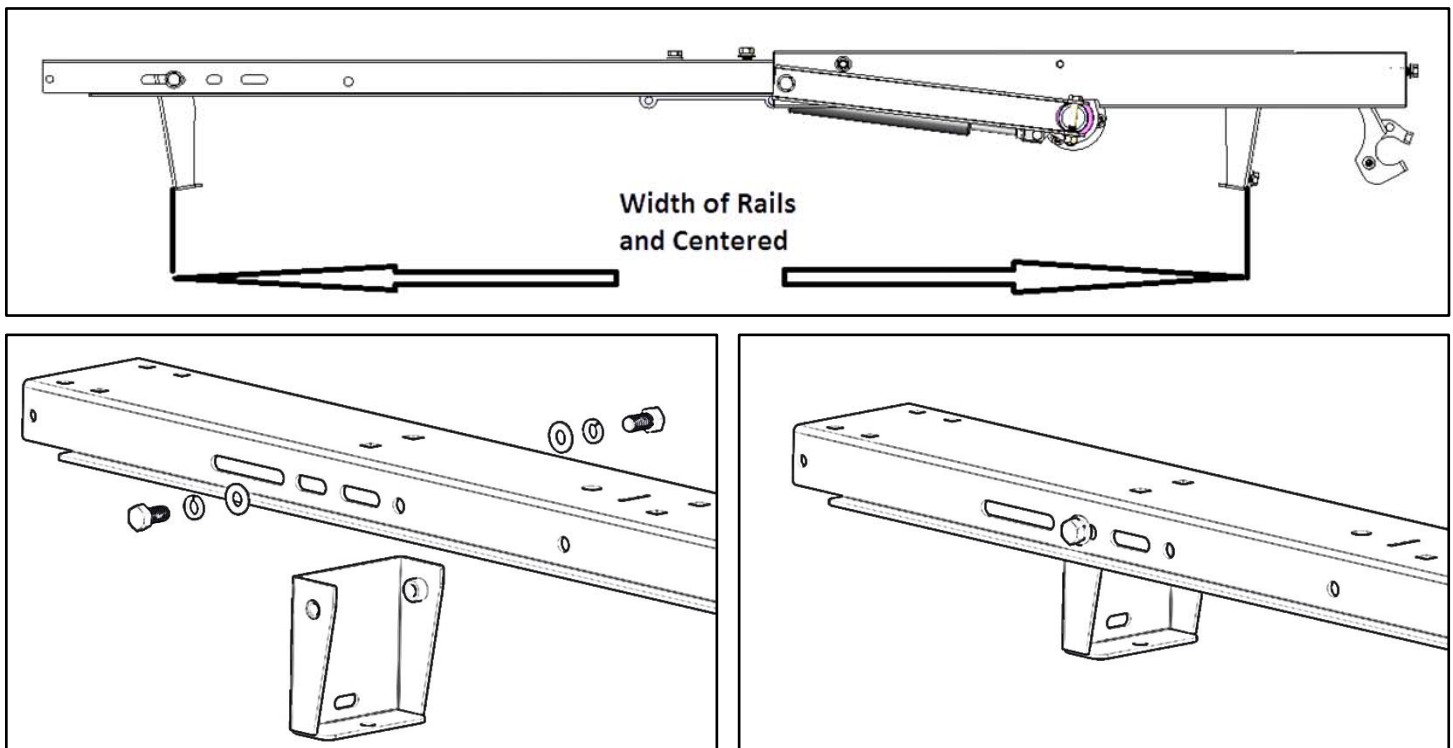

Step 5 – Installing Rack on Van

- First, line the rear foot up with the rear mount of van.
- Bolt rear foot to rear mount using 5/16" x 3/4" carriage bolts, 5/16" flat washers and a 5/16" lock nuts. (Driver Side Shown without roof and rack for clarity)
- In the front of the van, mount foot to previously installed rail using a 5/16" x 3/4" carriage bolts, 5/16" flat washers and a 5/16" lock nuts
- Adjust as necessary.
- Notice, the tall feet are installed at the rear.

Shown without rack and roof for clarity

REAR

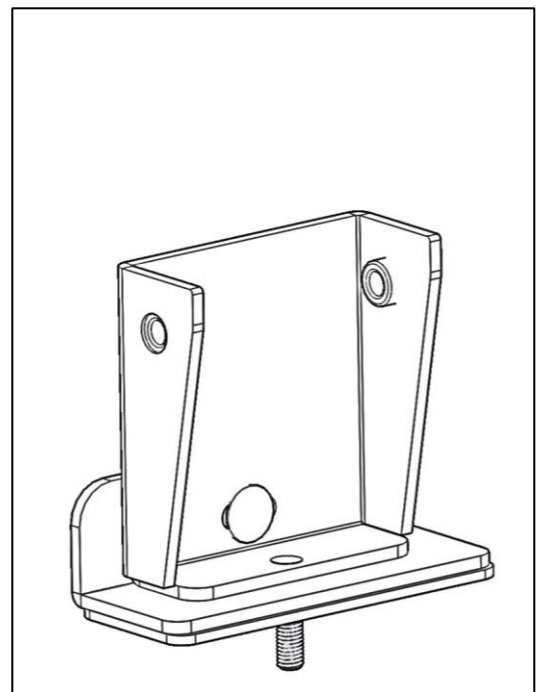
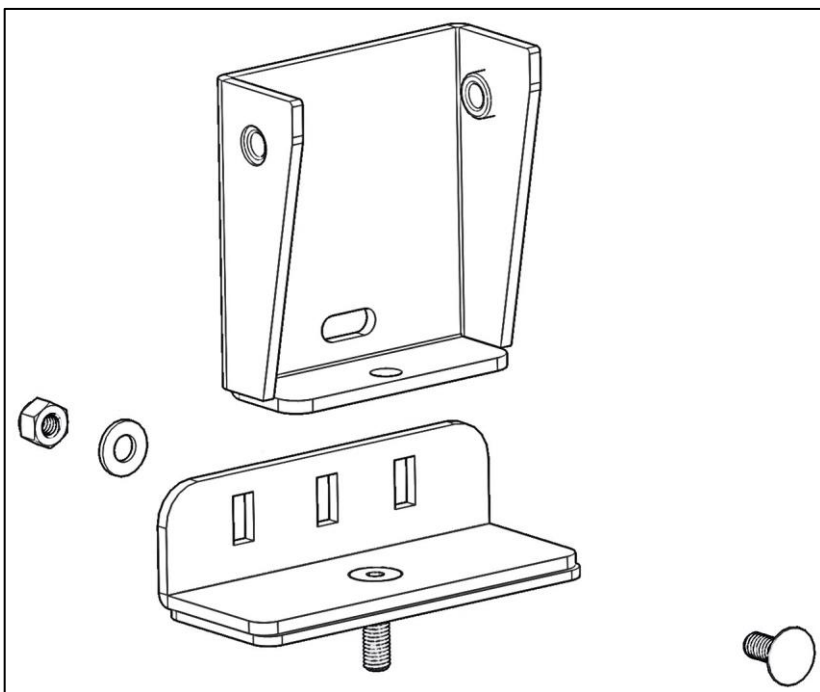

FRONT

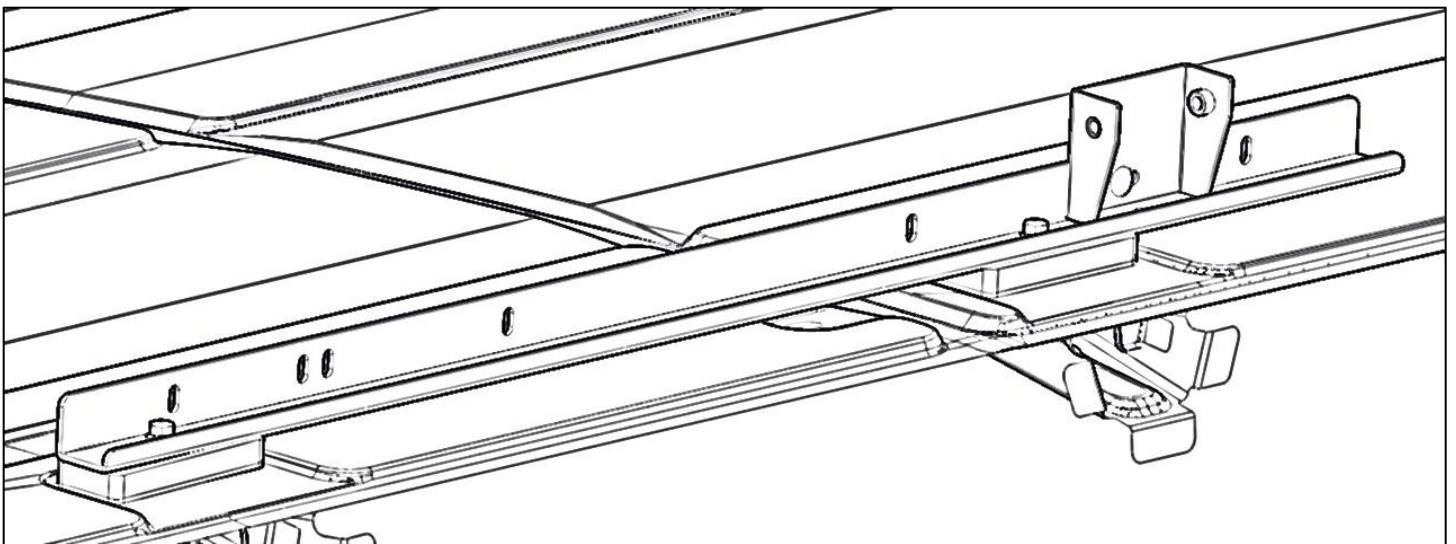
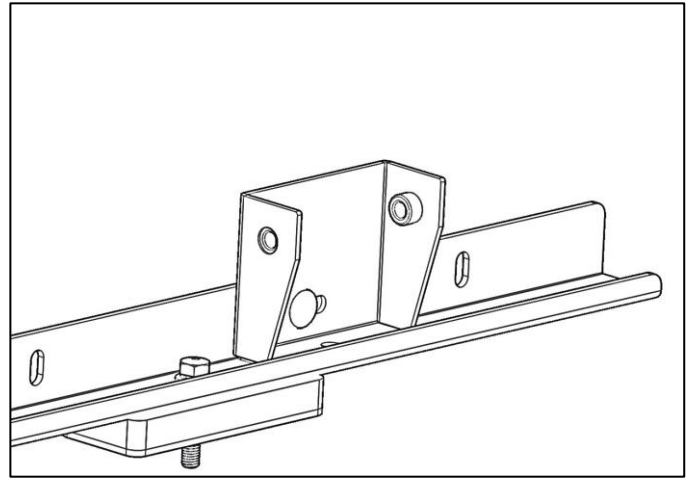
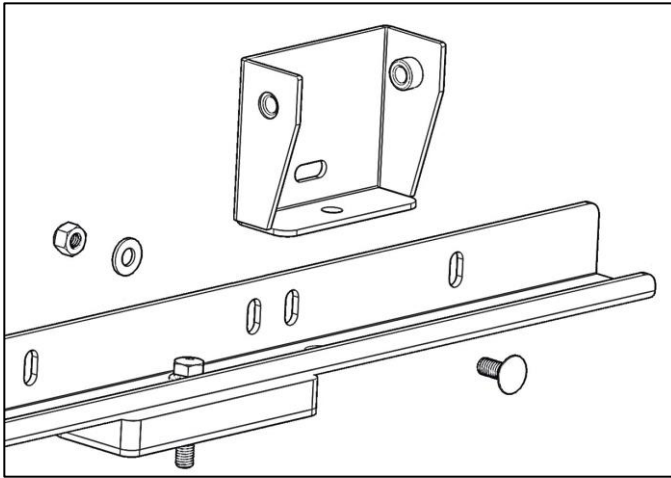

Notice the short feet are installed at the front.

Go back and ensure all hardware is tight. This includes into the roof, within the rack assembly and the mounting of the rack to roof brackets.

Your installation is complete.

