

Holman

Installation Guide

406NL

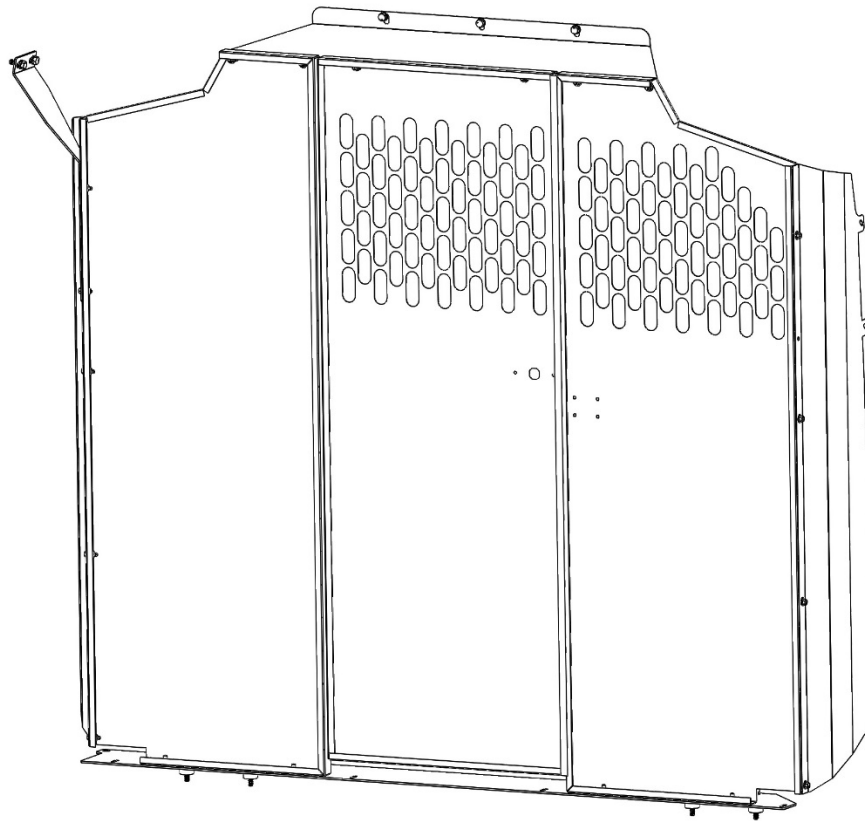

Holman
Rancho Cordova, CA 95742
800-343-7486
InstallationSupport@holman.com

***PLEASE READ ALL INSTRUCTIONS AND WARNINGS PRIOR TO ASSEMBLING,
INSTALLING, AND USING THIS PRODUCT***

Warning



Always check for wires, fuel tanks and lines, brake lines and other important vehicle functionality items prior to drilling and installing all products.

Tools Needed

3/8" Wrench and Socket	7/16" Wrench and Socket
13mm Wrench and Socket	1/4" Drill Bit

Table of Contents

Parts List	2
Hardware List	3
Step 1 Bolt Floor Plate	4
Step 2 Bolt Side Wings	5
Step 3 Handle Movement	6
Step 4 Mount Partition	6
Step 5 Mount Wings to Van	7
Step 6 Mount Top Wing	8



Before You Begin

- Read all instructions
 - Be sure to have partition (40640) assembled and ready to install.
-

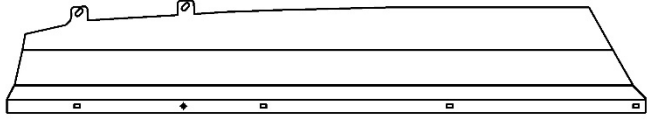
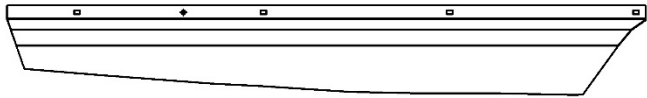
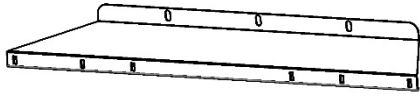
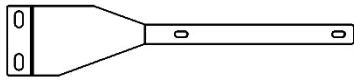
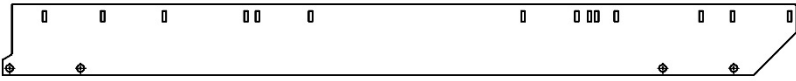
Parts

ITEM NO.		PART NUMBER	DESCRIPTION	QTY.
A		406NL-00-001	NV LR Passenger Wing	1
B		406NL-00-002	NV LR Driver Wing	1
C		406NL-00-003	NV LR Top Wing	1
D		406NL-00-006	NV HR DR BRK	1
E		406NHL-00-004-R1	NV HR/LR Floor Plate	1
		18-406NL	Hardware Kit	1

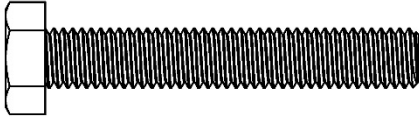
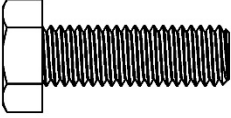
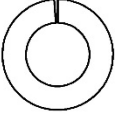
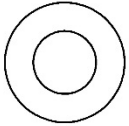
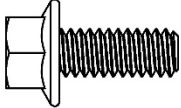
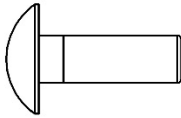
Hardware

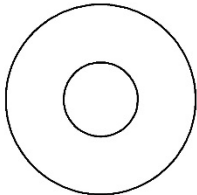
ITEM NO.	TO SCALE	PART NUMBER	DESCRIPTION	QTY.
1		91310A543	M8 x 50mm HH	4
2		91280A534	M8 x 25mm HH	5
3		91202A238	M8 Lock Washer	9
4		91166A270	M8 Flat Washer	9
5		92979A114	.25-20 x .625 Flange HH	15
6		90185A540	.25 X .75 Carriage Bolt	4
7		93298A110	.25-20 Flanged Nyloc Nut	19
8		.375ID x 1OD x .375T Nylon Spacer	.375 x 1.0 Nylon Spacer	12

Step 1 – Bolt Floor Plate

- Locate threaded embosses in floor of van.
- If a mat is installed in van, use a hole saw to expose threaded embosses.
- Place floor plate (E) into van in orientation shown. Have the angle cut end towards the slider door.

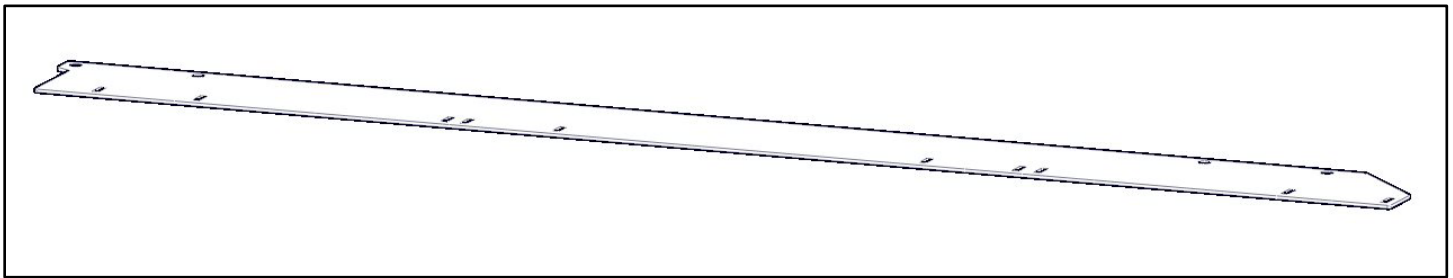
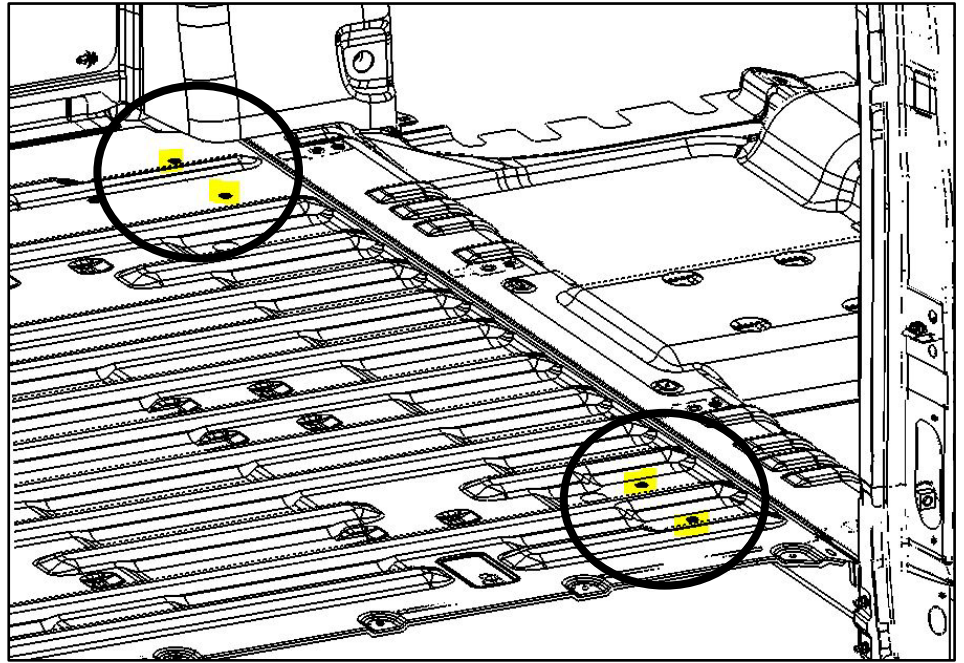

- Bolt to floor using a M8 x 50mm HH (1), a M8 lock washer (3) and a M8 flat washer (4) in orientation shown.
- In some situations, one to three nylon spacers will be needed under the floor plate (E) in order to have a rigid fitment.
- **SNUG TIGHTEN**, but allow movement.

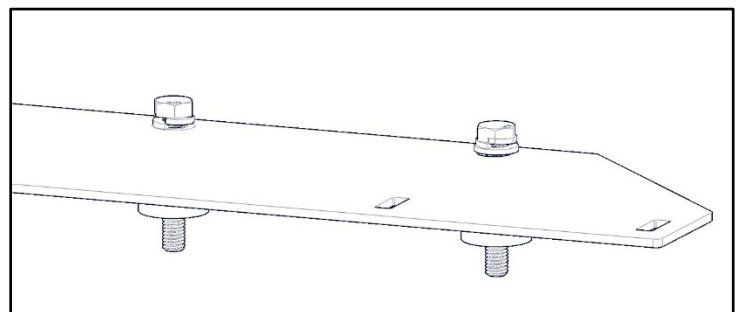
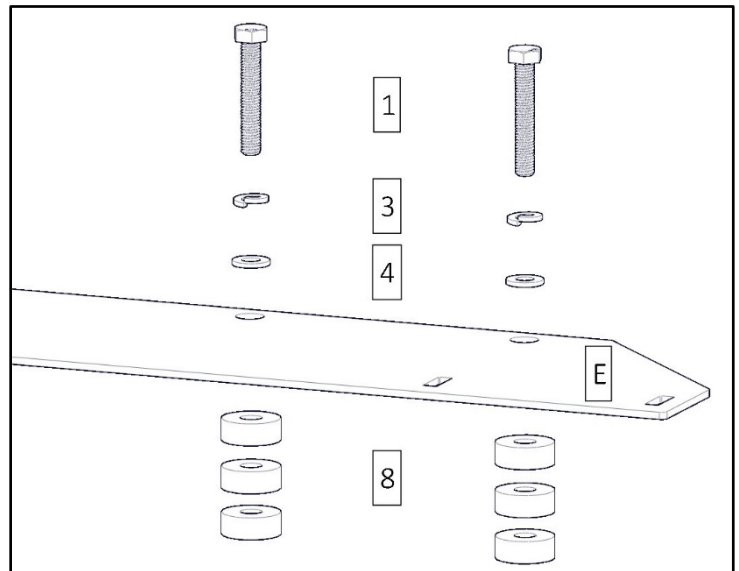

Step 2 – Bolt Side Wings

- Place wings (A & B) in orientation shown next to the partition (40640).
- Bolt together using a 1/4" x 5/8" flanged HH (5) and a flanged nyloc nut (7).
- On the both side wings (A&B), leave the top two holes from the top open.
- **SNUG TIGHTEN**,but allow movement.

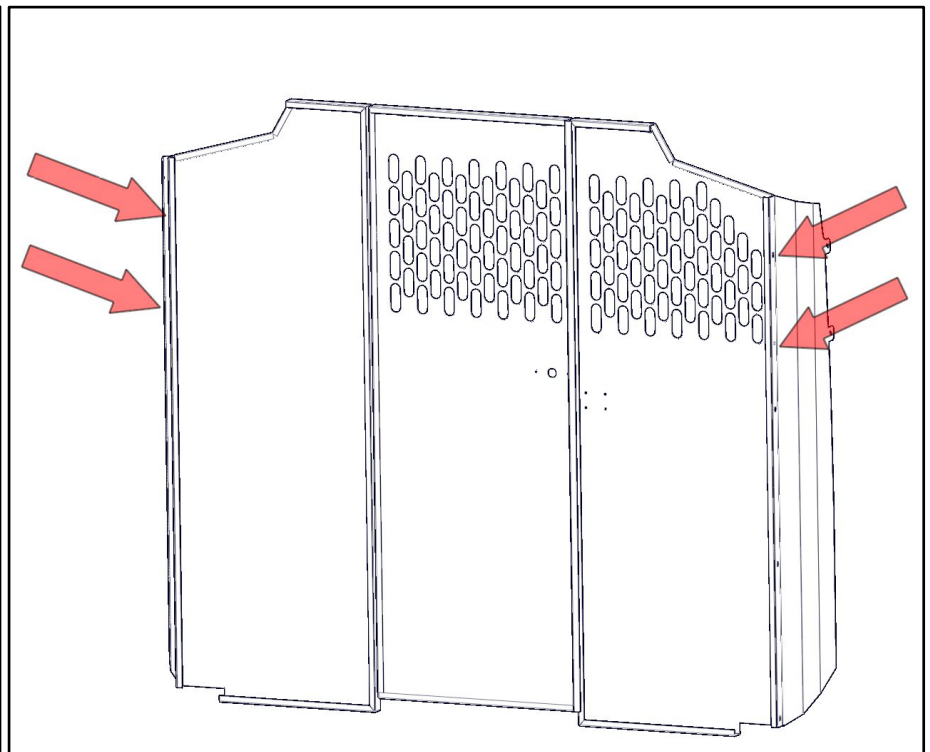
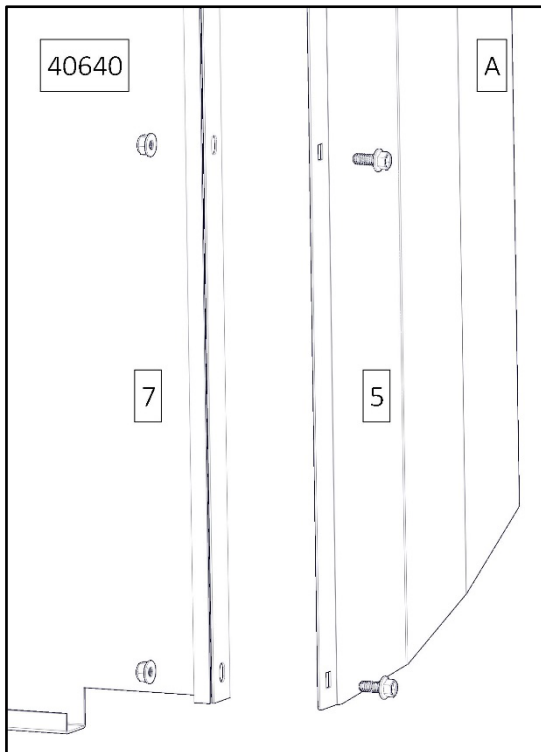
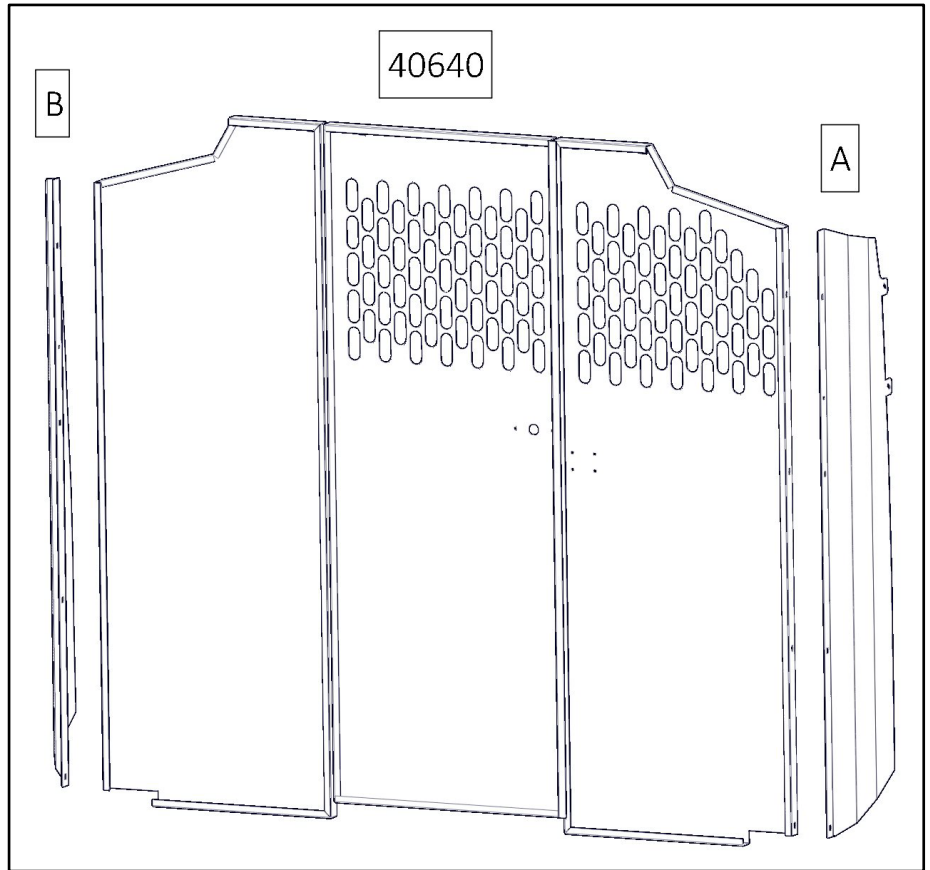

Step 3 – Handle Movement

- Inside of slider door, along the “B” pillar, remove the factory handle.
- Be careful when removing plastic caps on handle.
- Bolt handle to passenger side of wing kit/partition assembly where vacant holes were left in previous step.
- Use a 1/4" x 5/8" flanged HH (5) and a flanged nyloc nut (7).
- A .25" hole may need to be drilled into partiton. Use wing as a template.
- TIGHTEN.

Step 4 – Mount Partition

- Place assembled partition into van on top of floor plate installed in Step 1.
- Line the holes in the bottom of the partition with the slots in the floor plate.
- From underneath, insert carriage bolts (6) through the floor plate in the orientation shown.
- Bolt floor plate (E) to partition using carriage bolt (6) and flanged nyloc (7).
- SNUG TIGHTEN, but allow movement.

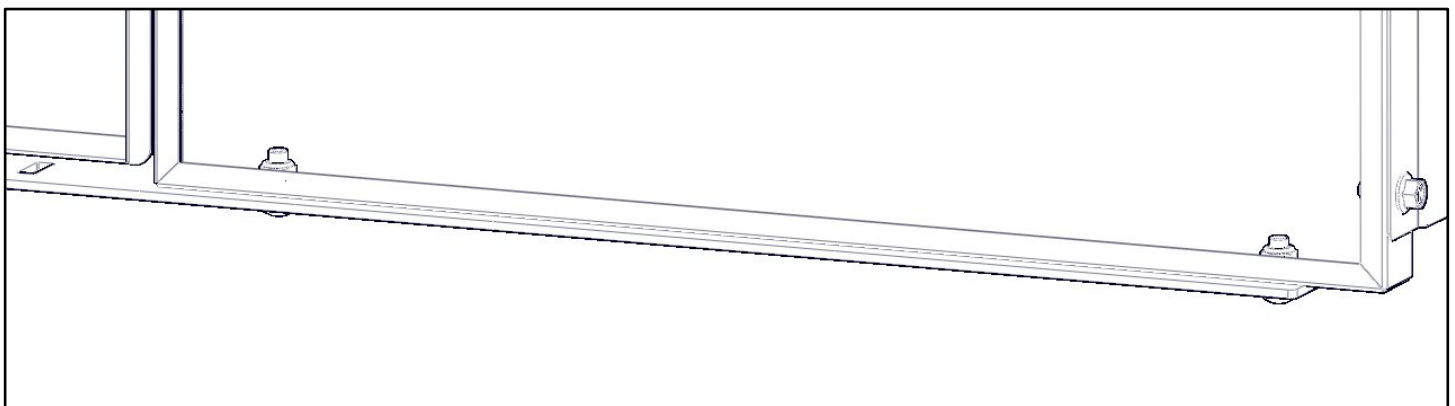
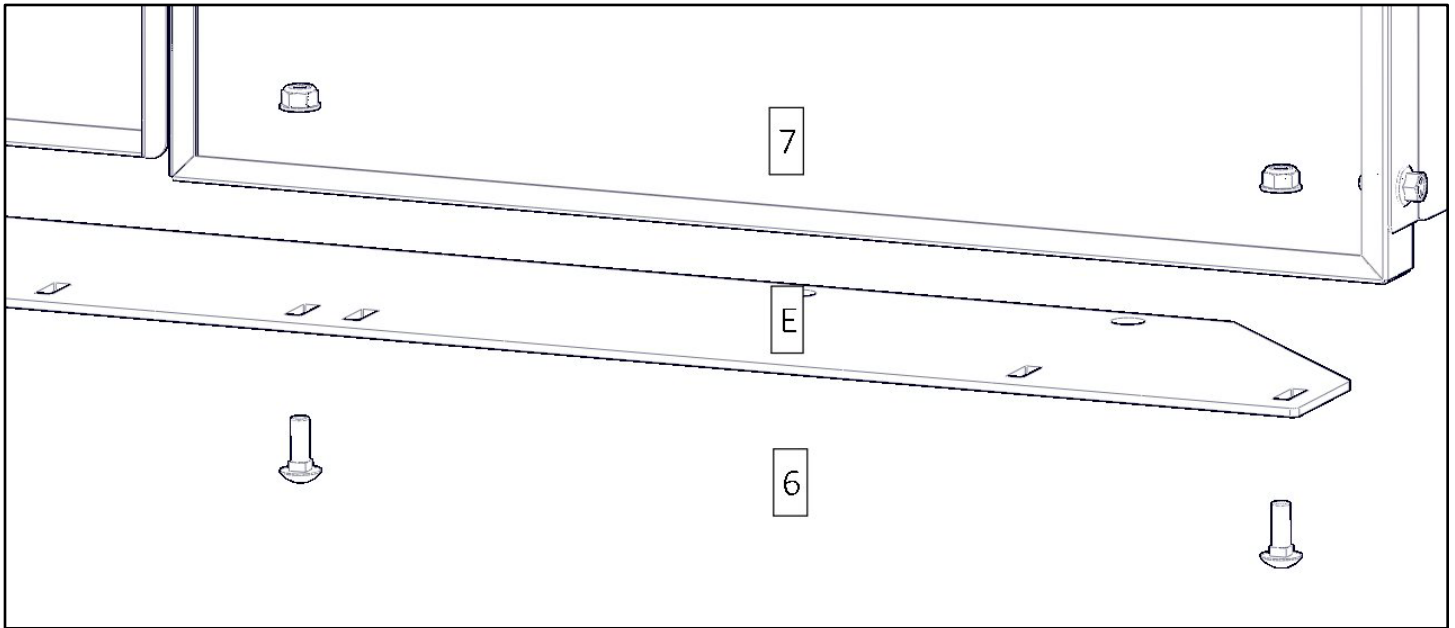

Step 5 – Mount Wings to Van

A. Passenger Side

- Mount passenger side wing to the embossed holes on the “B” pillar where the handle was removed in Step 3.
- Use hardware from Step 3 to bolt passenger side wing to van.
- Snug Tighten, but allow movement.

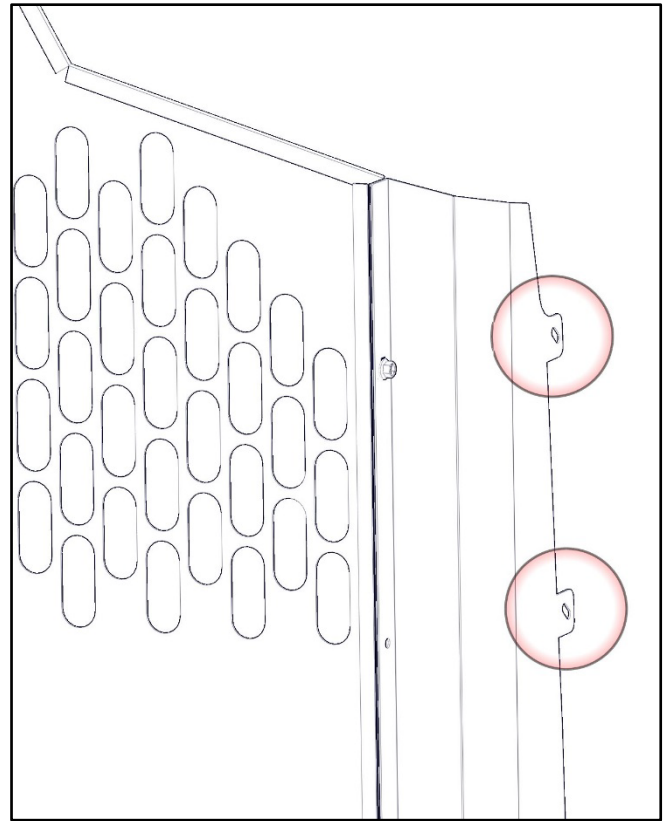

B. Driver Side

- Bolt driver side bracket (D) to the top holes left open in Step 2.
- Bolt together using a 1/4" x 5/8" flanged HH (5) and a flanged nyloc nut (7).
- Snug Tighten, but allow movement.

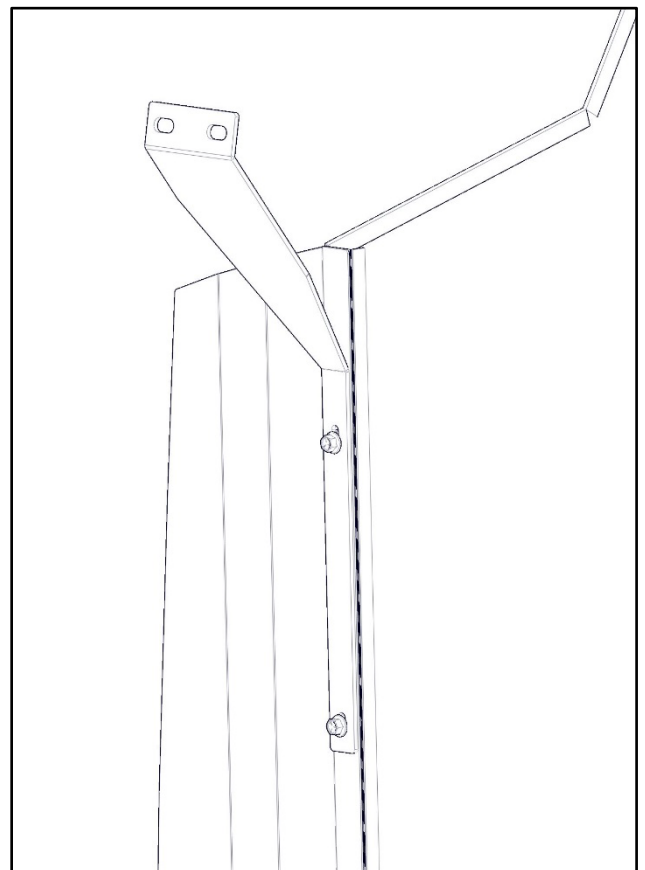
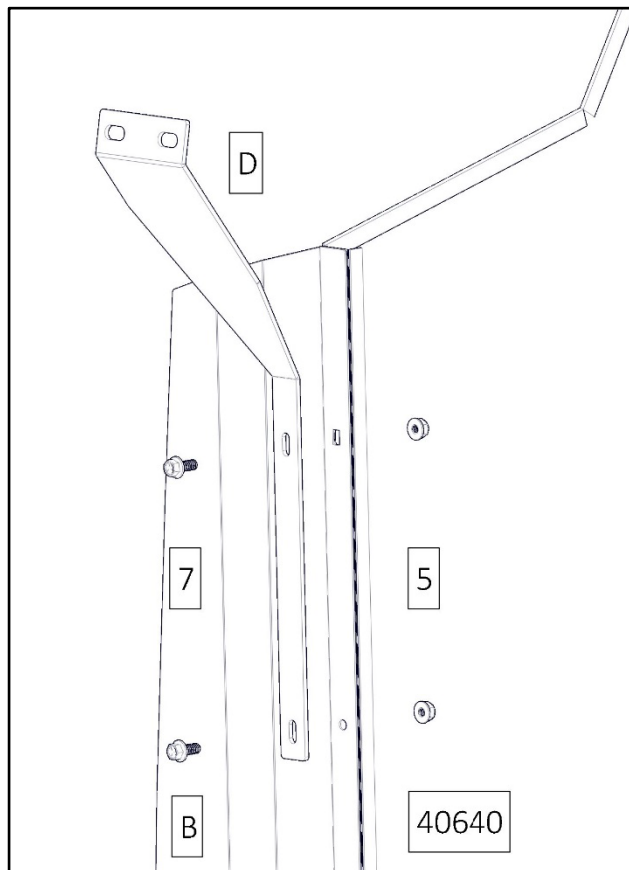

- Bolt other side of bracket to threaded embosses in side of van.
- Use a M8 x 25mm HH (2), a M8 lock washer (3) and a M8 flat washer (4) in orientation shown.

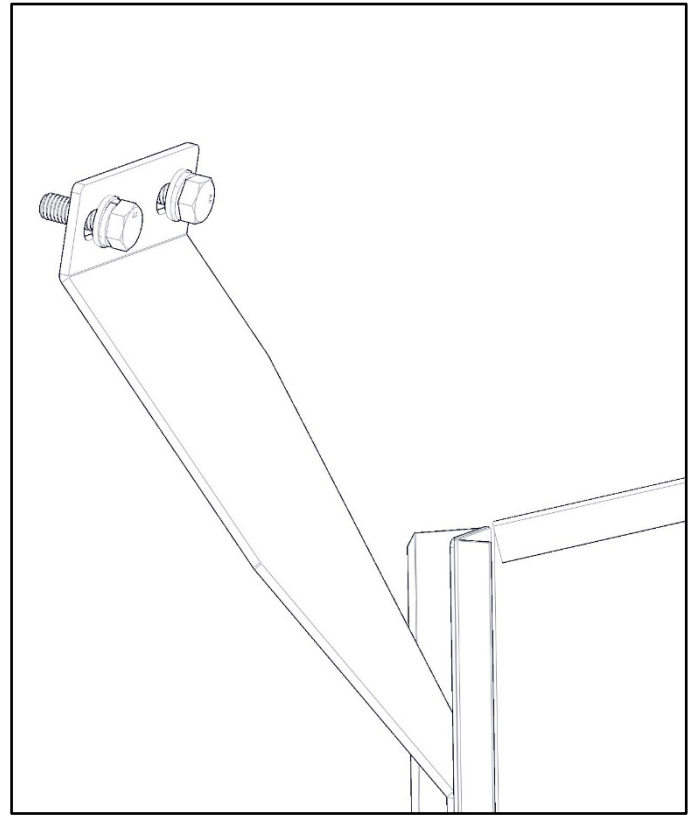
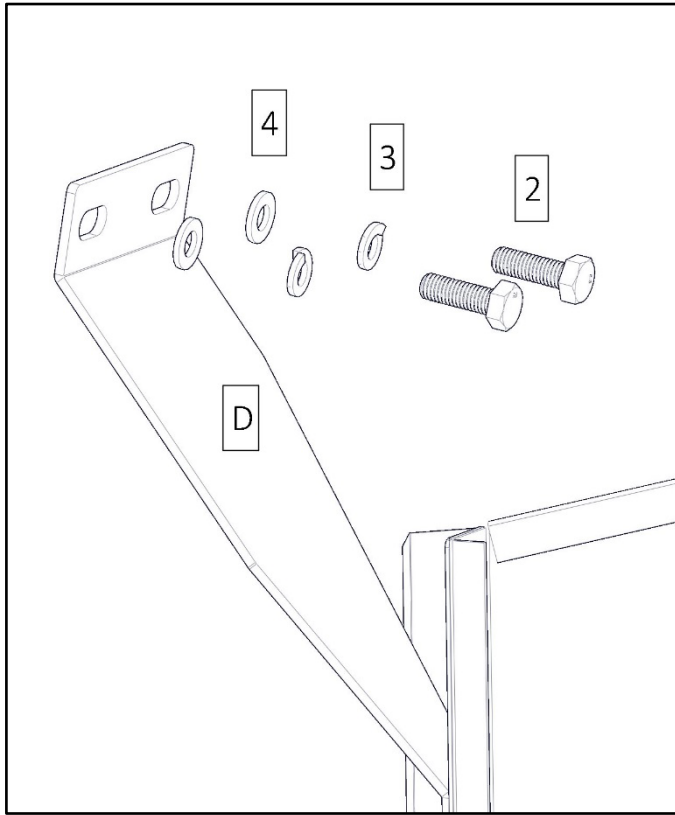

Step 6 – Mount Top Wing to Van

- Place top wing on top of partition in the orientation shown.

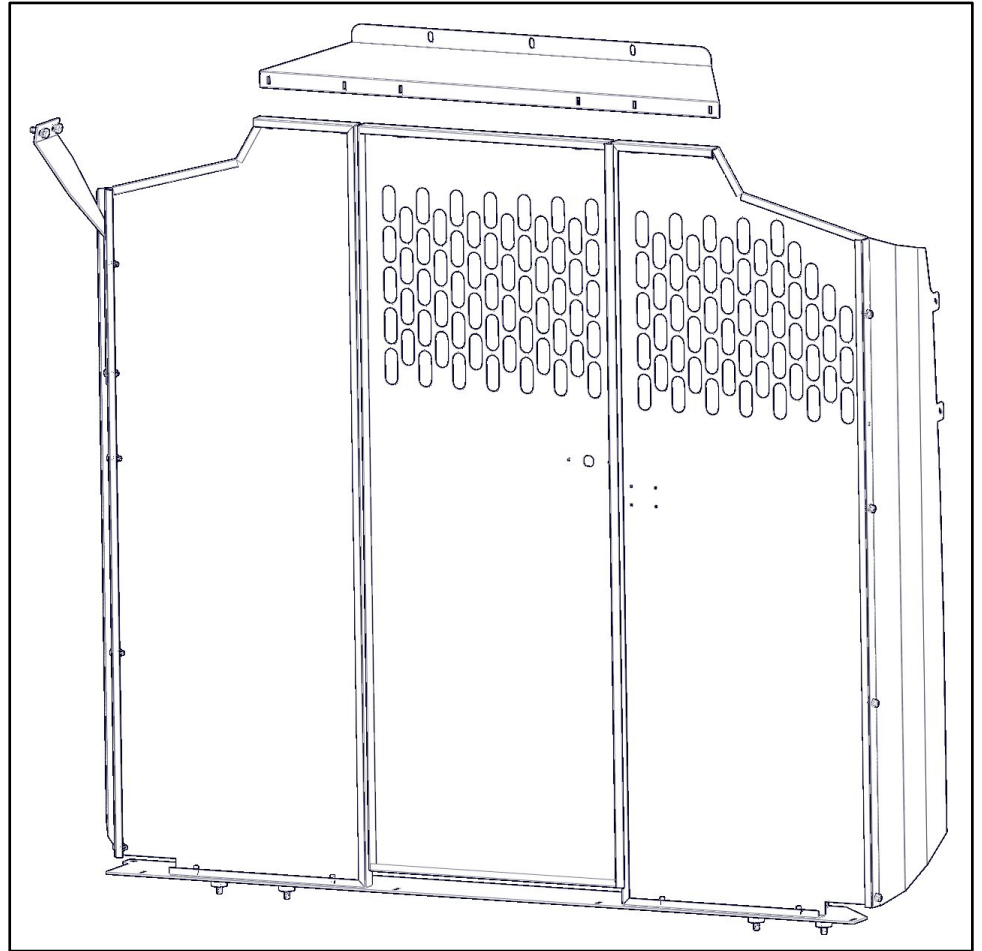

- Bolt into the top of the partition using 1/4" x 5/8" flanged HH (5) and a flanged nyloc nut (7).

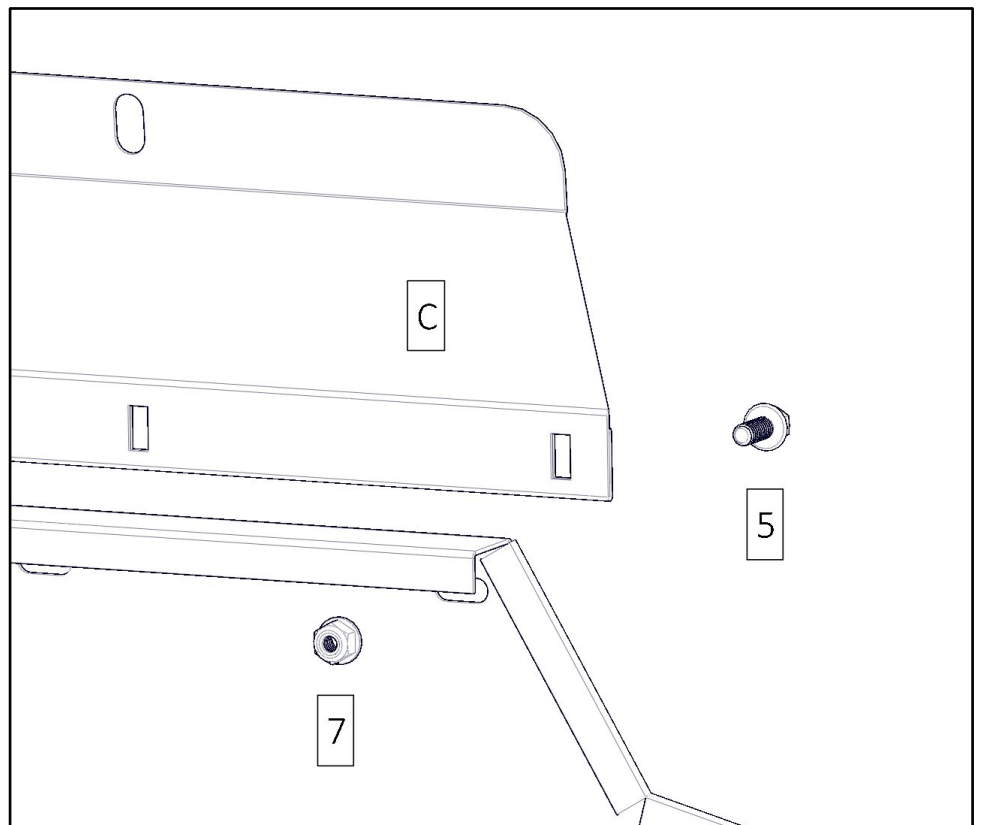

- Repeat for a total of 6x.

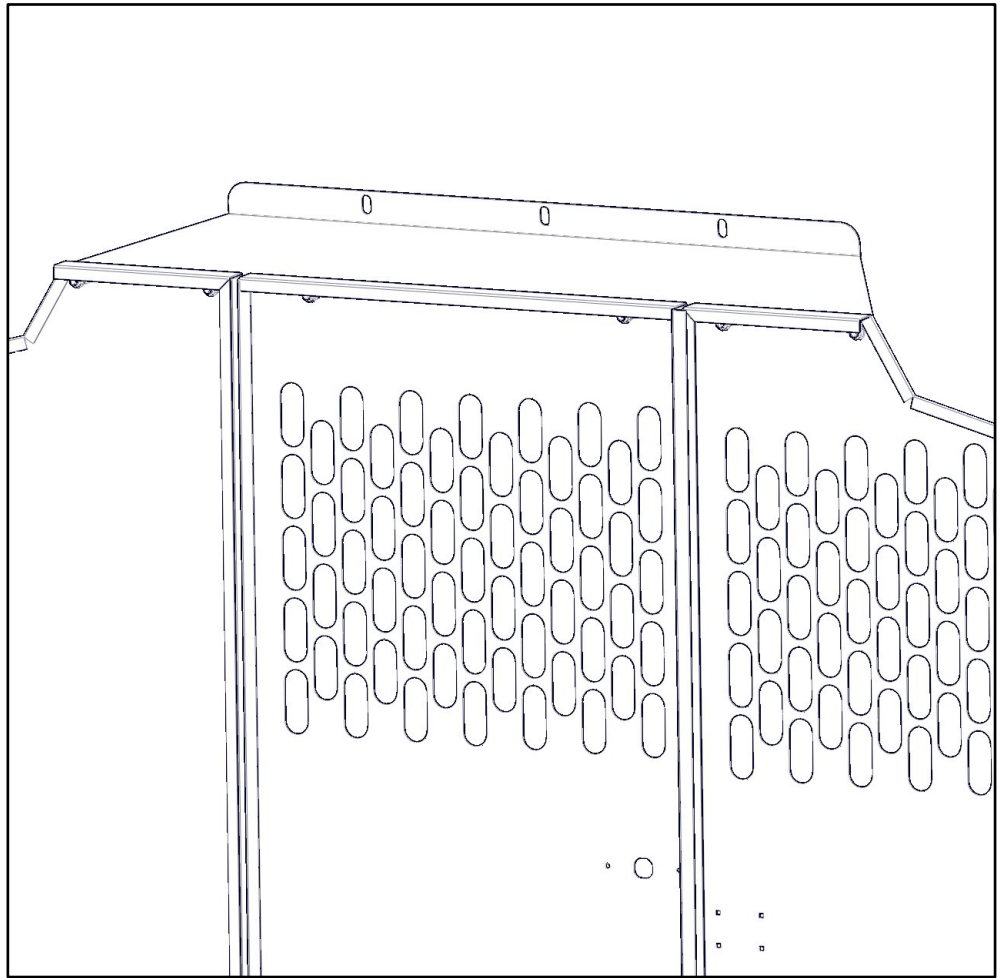

- Bolt top wing into threaded embosses across the roof support using a M8 x 25mm HH (1), a M8 lock washer (3) and a M8 flat washer (4) in orientation shown.

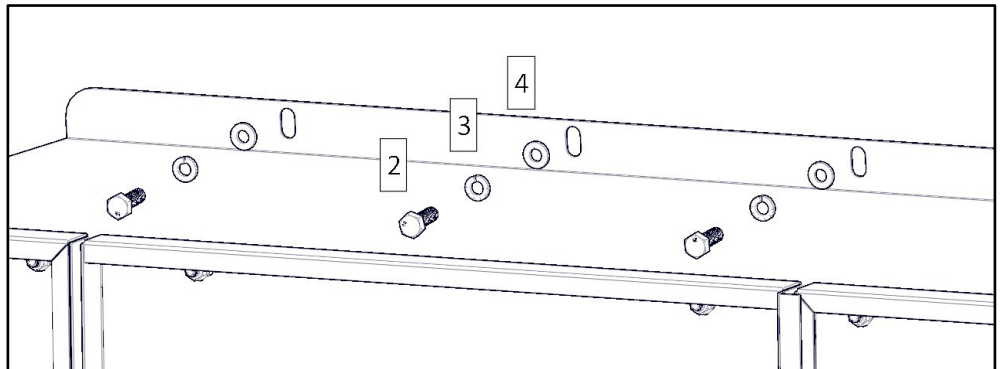

- Repeat for a total of 3x.

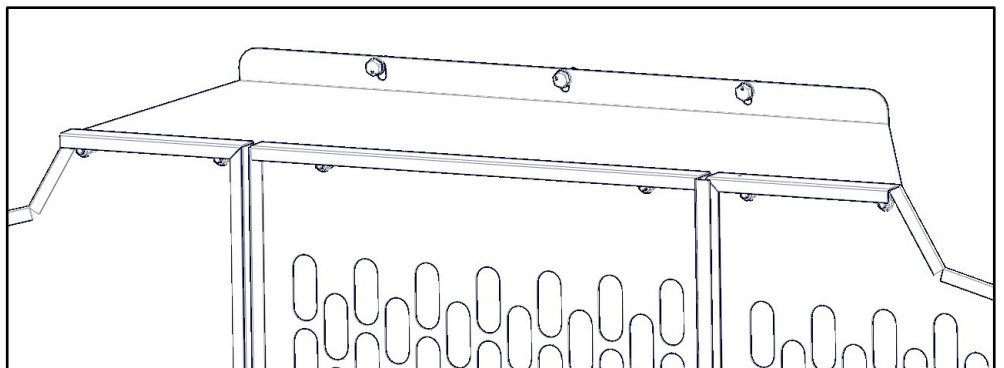

SQUARE AND ALIGN PARTITION TO YOUR PREFERENCE.
TIGHTEN ALL HARDWARE FROM ALL PREVIOUS STEPS
YOUR INSTALLATION IS NOW COMPLETE.

