

# Holman

---

## Instruction Guide 40240

---

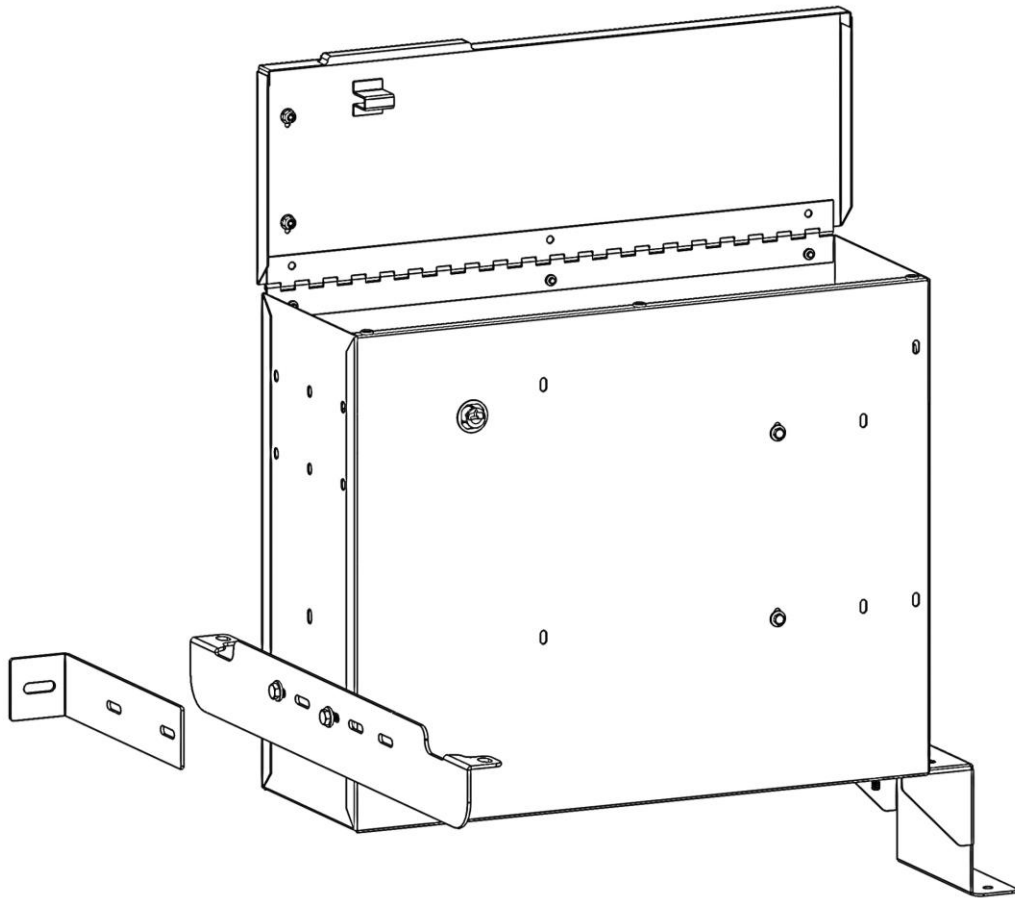

---

Holman  
Rancho Cordova, CA 95742  
800-343-7486  
InstallationSupport@Holman.com

---

**\*PLEASE READ ALL INSTRUCTIONS AND WARNINGS PRIOR TO ASSEMBLING, INSTALLING, AND USING THIS PRODUCT.\***

**Warning**



**Always check for wires, fuel tanks and lines, brake lines and other important vehicle functionality items prior to drilling and installing all products.**

**Tools Needed**

7/16" Socket and Wrench	7/16", 9/16" Box Wrenches
3/8" Nut Driver Bit	25/64" Drill Bit
Drill Bit Stop Collar	Plus Nut Installation Tool (P9902)*
Drill	

\*Sold separately.

**Table of Contents**

Before You Begin..... 2

Parts ..... 2

Hardware ..... 3

Ford Transit Installation ..... 4

    Step 1F – Attach Bottom Bracket ..... 4

    Step 2F – Attach Transit Seat Mount to Van Seat Frames ..... 4

    Step 3F – Prepare for Installation..... 5

    Step 4F – Install Plus Nuts into Floor..... 6

    Step 5F – Install Data File ..... 6

    Step 6F – Finish Installation..... 7

ProMaster Installation ..... 8

    Step 1P - Attach Bottom Bracket..... 8

    Step 2P - Attach Front Bracket ..... 8

    Step 3P - Prepare Floor Installation ..... 8

    Step 4P – Install Plus Nuts into Floor ..... 9

    Step 5P – Install Data File ..... 10

    Step 6P – Finish Installation ..... 10



## Before You Begin

- Read all instructions prior to assembling or installing any Holman product.
- **Always locate your installation locations prior to performing any work.**
- ENSURE SAFETY WHILE INSTALLING OR DRILLING INTO VEHICLE. Be sure to check installation location prior to drilling or screwing into the vehicle. Use a drill bit stop collar to maintain appropriate drill depth.
- **Plus Nut Installation Tool Kit P9902 is not included and must be purchased separately.**
- **Additional self-drilling hardware has been added as an installation alternative. The installation of plus nuts is the recommended installation method.**

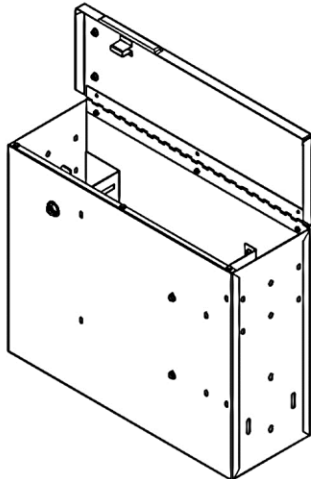
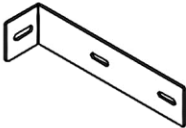
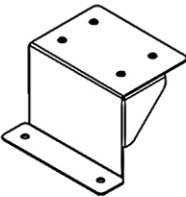
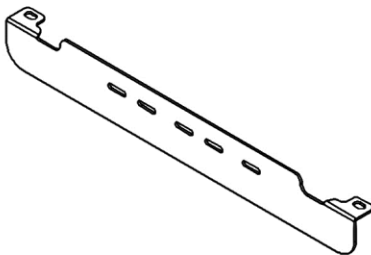
## Parts

NO.	ITEM	PART NUMBER	DESCRIPTION	QTY.
1		40240-10	DRIVER DATA FILE	1
2		40240-106	FRONT BRACKET	1
3		101074	REAR MOUNTING BRACKET	1
4		101068	TRANSIT SEAT MOUNT	1
5		18-00567	HARDWARE KIT	1

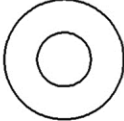
## Hardware

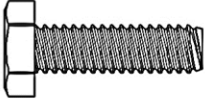
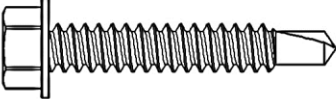
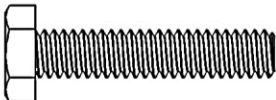
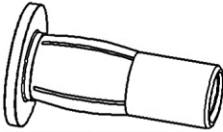
ITEM	HARDWARE TO SCALE	PART NUMBER	DESCRIPTION	QTY.
1		33078	1/4" FLAT WASHER	10
2		33618	1/4" LOCK WASHER	5
3		37018	1/4"-20 NYLON INSERT LOCK NUT	3
4		13004	1/4"-20 X 7/8" HEX HEAD BOLT	5
5		90064A709	1/4" X 1-1/2" SELF- DRILLING SHEET METAL SCREW	3
6		13800	1/4"-20 X 1-1/4" HEX HEAD BOLT	2
7		920313726	1/4"-20 PLUS NUT	2

## DO NOT EXCEED MANUFACTURERS WEIGHT CAPACITY FOR ROOF

### Ford Transit Installation

#### Step 1F – Attach Bottom Bracket

- Using two 1/4" x 7/8" hex bolt, 1/4" lock washers and 1/4" flat washers, bolt rear mounting bracket to main date file assembly through the rear holes, as shown.
- Snug tighten but allow for movement.

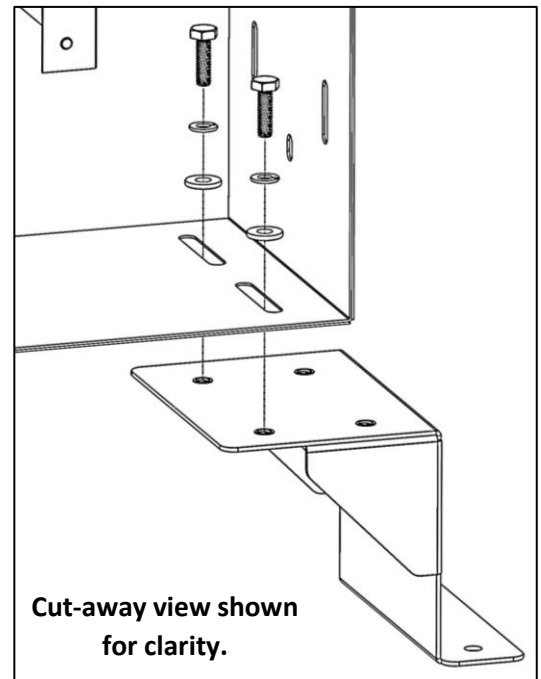

#### Step 2F – Attach Transit Seat Mount to Van Seat Frames

- Remove the socket head screw and washer from both the driver side and passenger side seat frames, as shown.

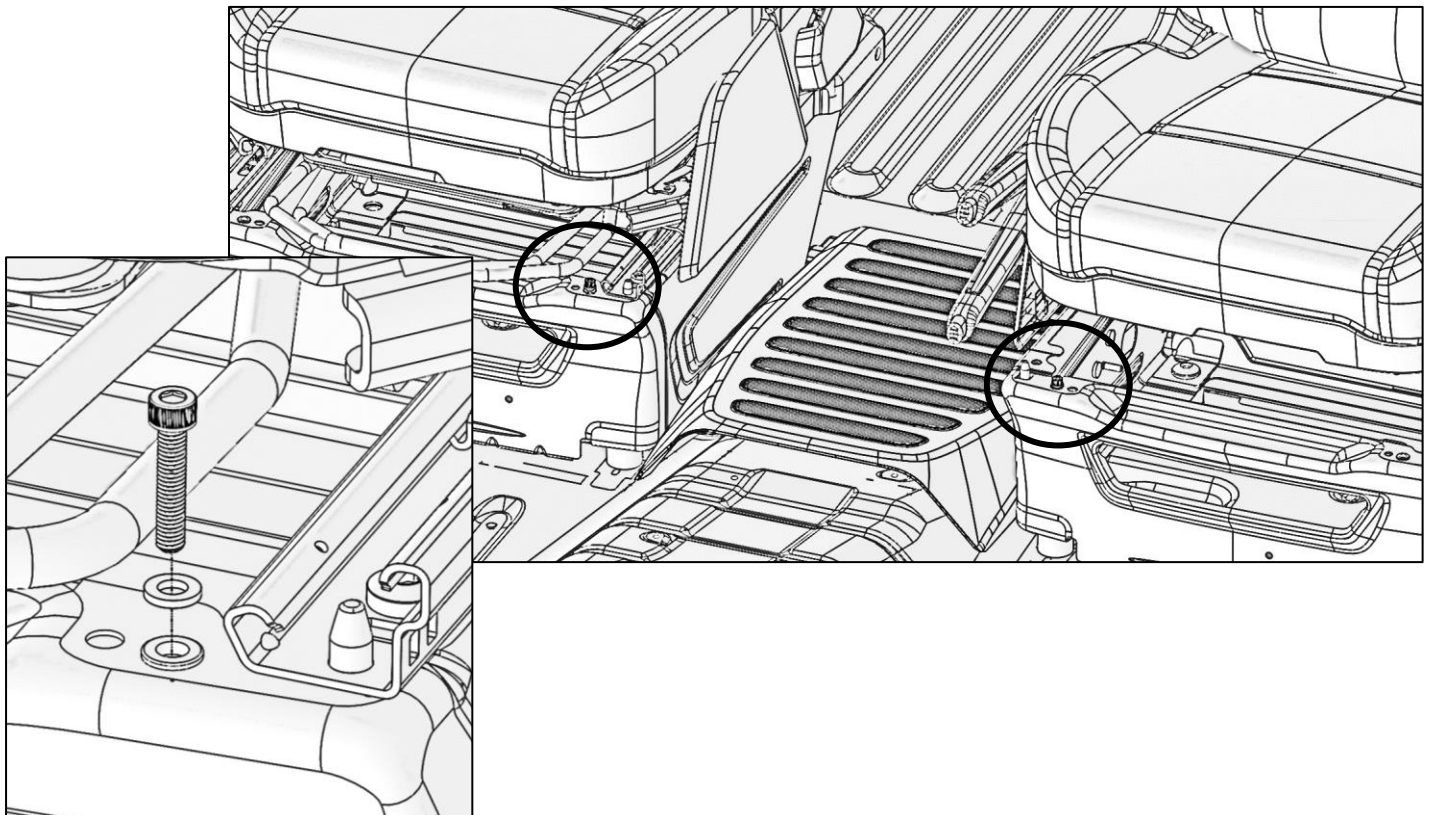



- Using the previously removed socket head screws, bolt the Transit seat mount to both the driver side and passenger side seat frames.
- Snug tighten but allow for movement.

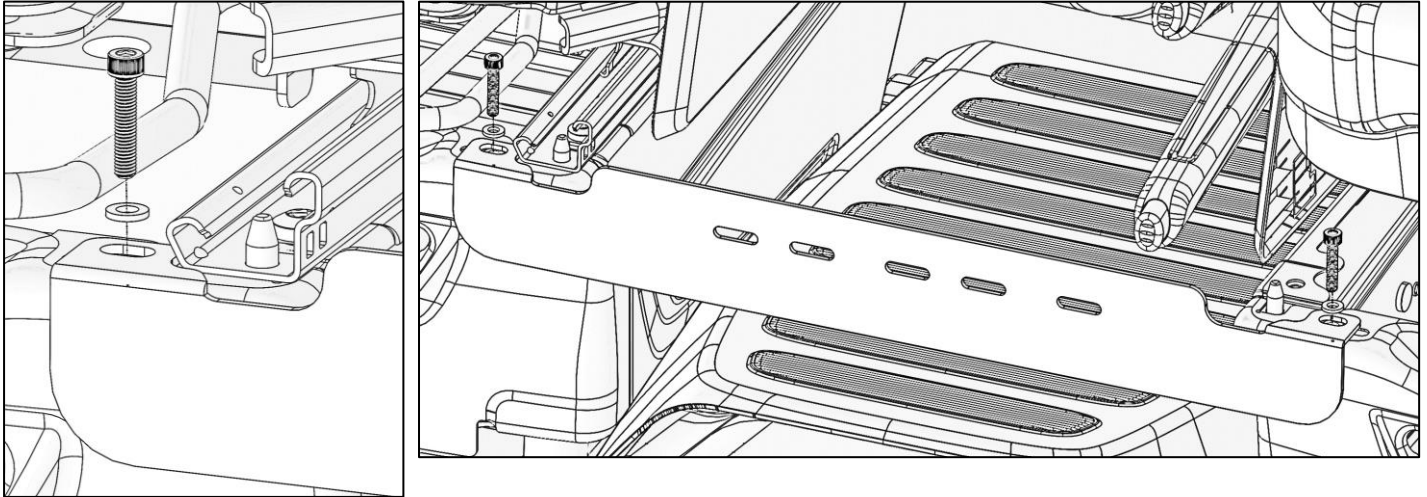

## Step 3F – Prepare for Installation

- Place data file into van.
- Put in between seats against Transit seat mount with holes in front aligned. **Be sure data file is snugly against the passenger side and the rear support bracket is past the rear of the rib in the floor.**
- Mark the slots in the rear mounting bracket onto the mat or floor.
- Remove assembly.

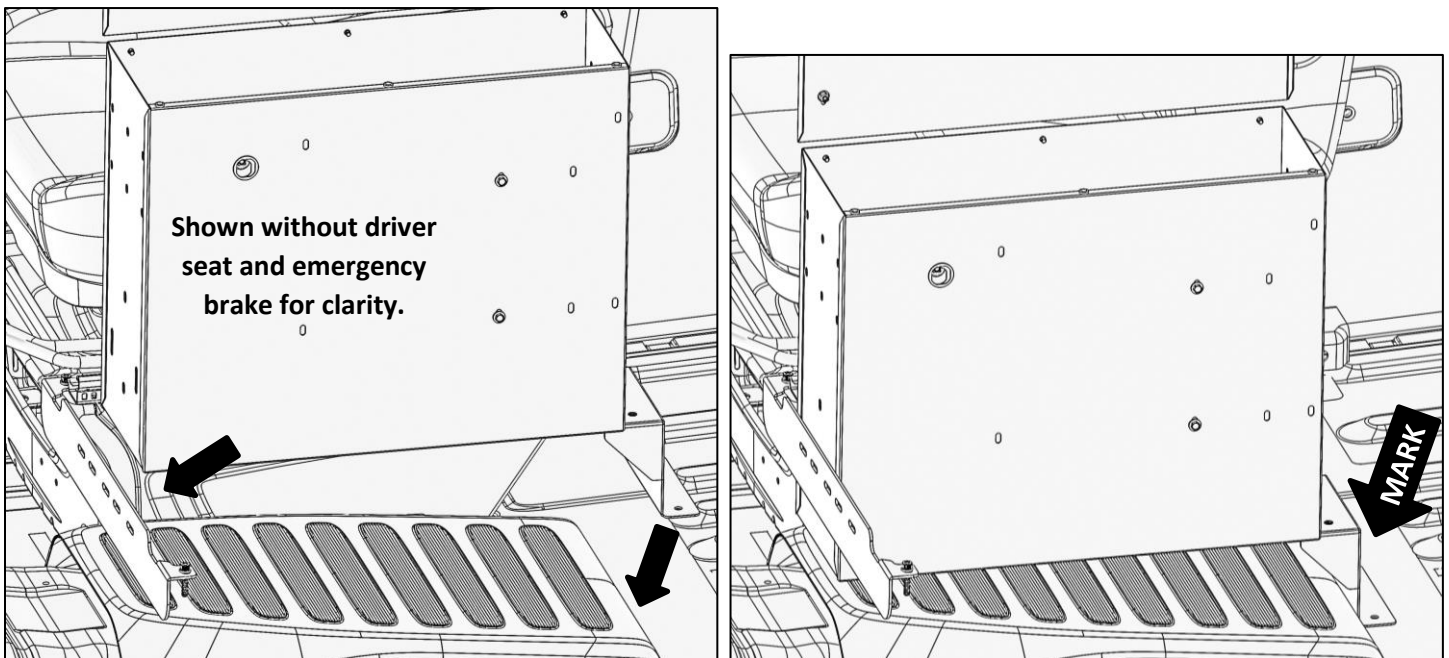

## Step 4F – Install Plus Nuts into Floor



**DO NOT drill beyond depth of floor or upper installation surface. Always check for wires, fuel tanks and lines, brake lines and other important vehicle functionality items prior to drilling and installing all products.**

- At each marked location **IN THE FLOOR**, drill hole using 25/64" drill bit and appropriate sized drill-bit stop collar. If 25/64" drill bit is not available, a 3/8" drill bit can be used, although it may be necessary to tap in the plus nuts.
- Insert 1/4" x 2-1/4" hex head bolt through 1/4" flat washer and plus nut installation tool, and then screw bolt into plus nut. Knurled end of plus nut tool must be directed away from bolt head and contacting plus nut.
- Insert plus nut into hole with plus nut tool attached.
- Using the 9/16" box wrench, hold the plus nut tool stationary and then tighten hex head bolt until plus nut is tightly gripping and does not spin when hex bolt is loosened.
- DO NOT overtighten plus nut.
- Using the 9/16" box wrench, hold the plus nut tool stationary to remove the plus nut tool.

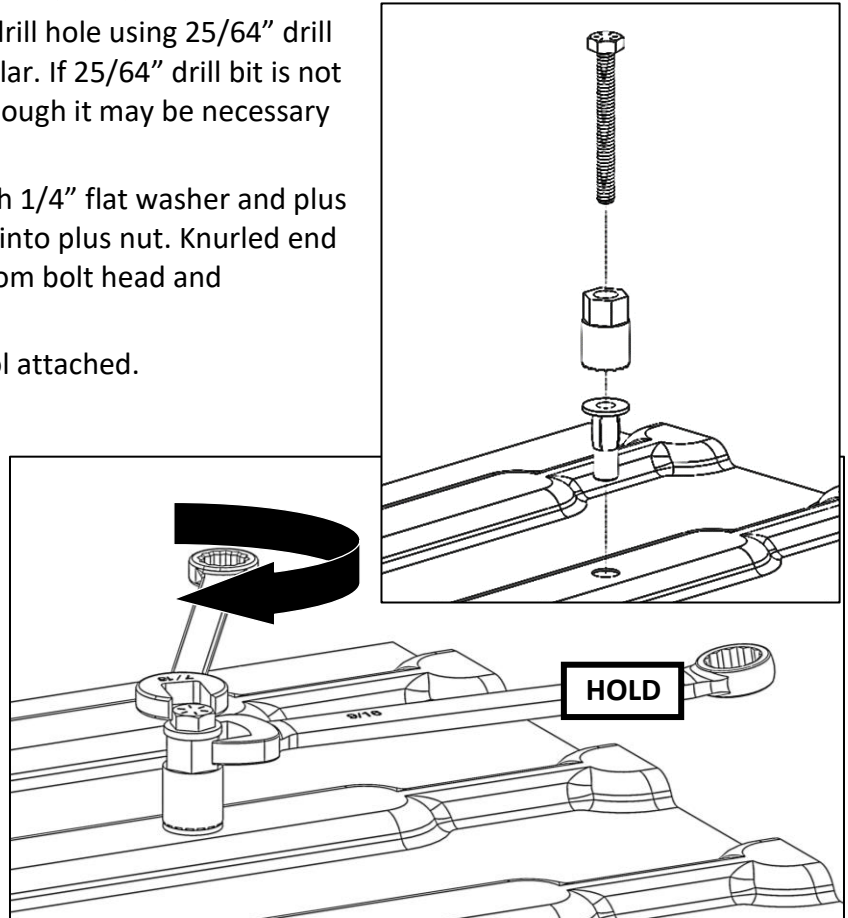

## Step 5F – Install Data File

- Bolt the Transit seat mount to the front of the main assembly using two 1/4" x 7/8" hex bolts, four 1/4" flat washers and two 1/4" lock nuts.
- Snug tighten but allow for movement.

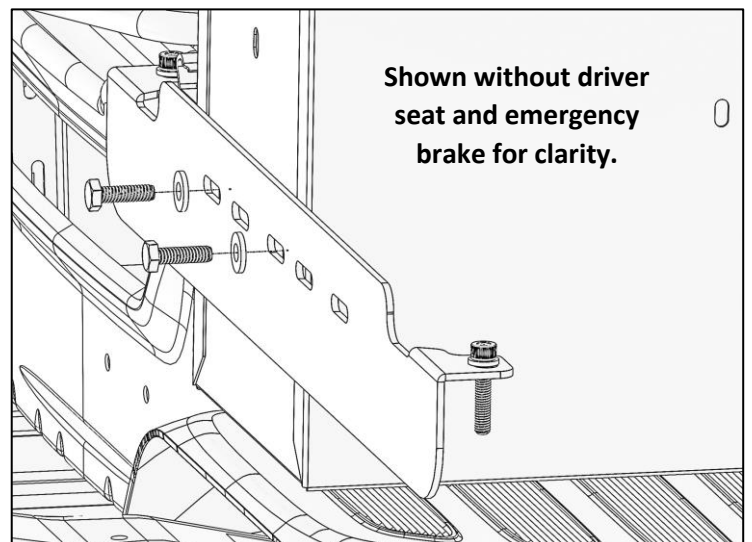

- Using two 1/4" x 1-1/4" hex head bolts, 1/4" lock washers, and 1/4" flat washers, install data file with rear mounting bracket to plus nuts in floor.
- Snug tighten but allow for movement.

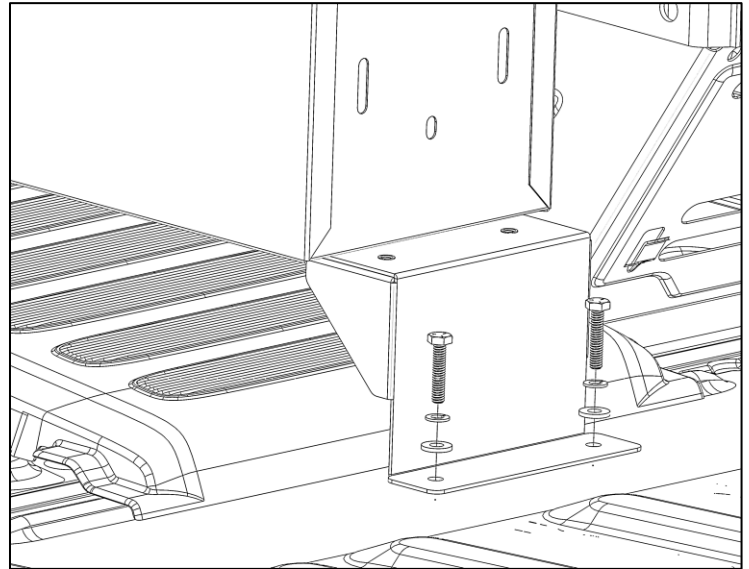

## Step 6F – Finish Installation

- Align and square the driver data file.
- Go back and TIGHTEN all bolts.

**YOUR INSTALLATION IS NOW COMPLETE.**



## ProMaster Installation

### Step 1P - Attach Bottom Bracket

- Using two 1/4" x 7/8" hex bolt, two 1/4" lock washers and two 1/4" flat washers, bolt base bracket to main assembly through the rear holes as shown..
- Snug tighten but allow for movement.

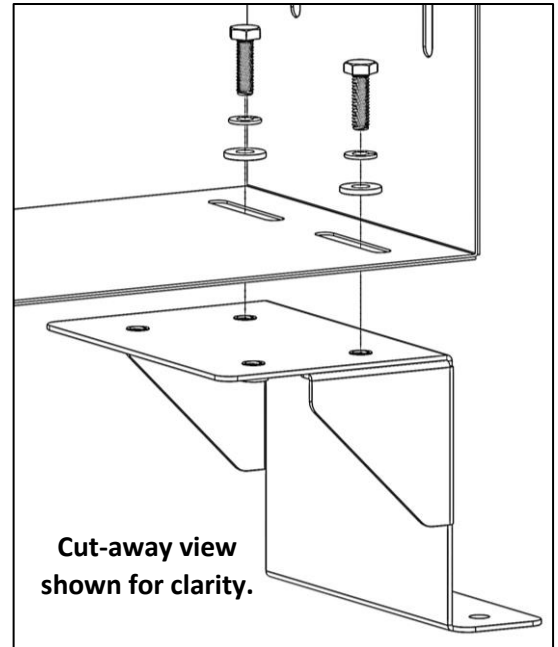

### Step 2P - Attach Front Bracket

- Bolt the front bracket to the front of the main assembly using two 1/4" x 7/8" hex bolt, four 1/4" flat washers and two 1/4" lock nuts.
- Snug tighten but allow for movement.

**We recommend having bracket all the way towards the bottom of the slots.**

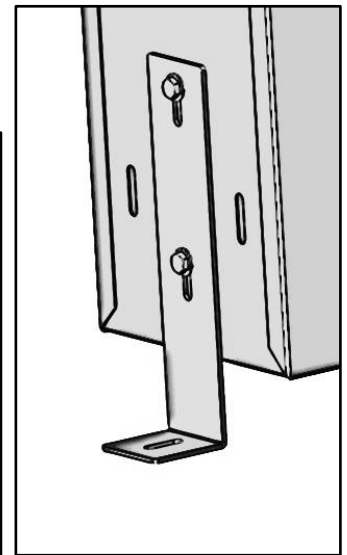
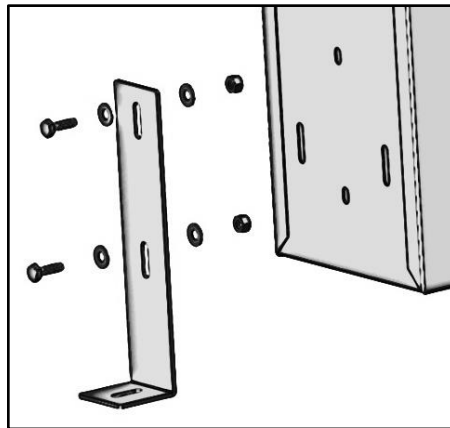

### Step 3P - Prepare Floor Installation

- Place data file assembly with mounting brackets into van between seats.
- Align and square data file.

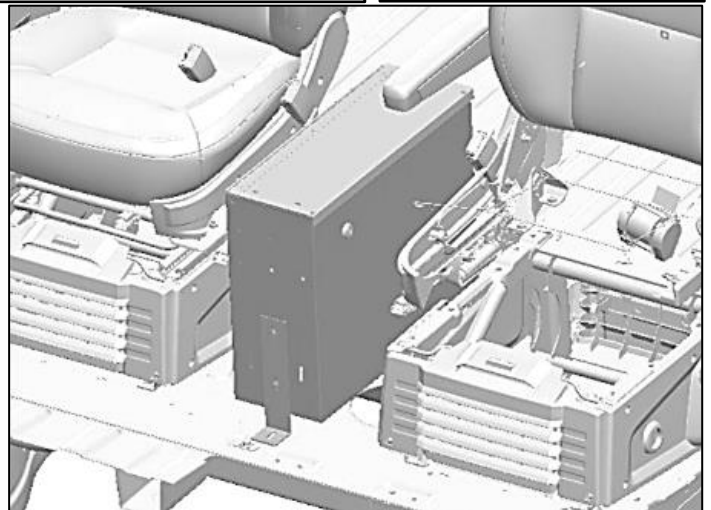

- For the rear mounting bracket, mark the two slots onto the floor of the van.
- Remove main assembly from van.



**Check under the mat where previous slots were marked to ensure installation will not interfere with anything important.**



**Check under the mat where L-shaped bracket is located to ensure installation will not interfere with anything important.**

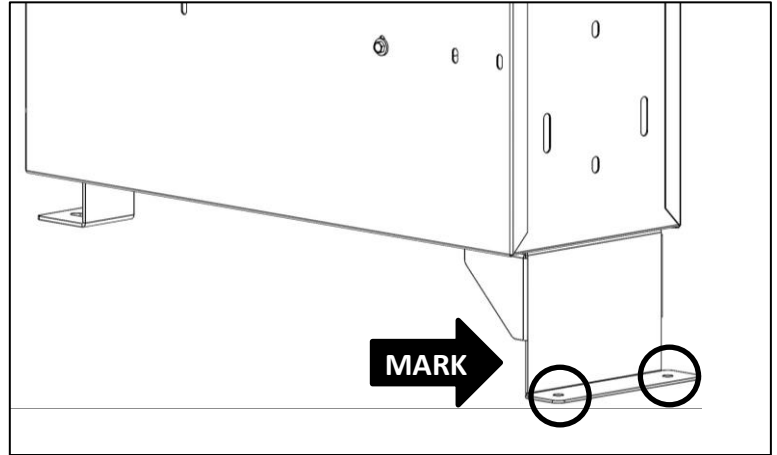

### Step 4P – Install Plus Nuts into Floor



**DO NOT drill beyond depth of floor or upper installation surface. Always check for wires, fuel tanks and lines, brake lines and other important vehicle functionality items prior to drilling and installing all products.**

- At each marked location **IN THE FLOOR**, drill hole using 25/64" drill bit and appropriate sized drill-bit stop collar. If 25/64" drill bit is not available, a 3/8" drill bit can be used, although it may be necessary to tap in the plus nuts.
- Insert 1/4" x 2-1/4" hex head bolt through 1/4" flat washer and plus nut installation tool, and then screw bolt into plus nut. Knurled end of plus nut tool must be directed away from bolt head and contacting plus nut.
- Insert plus nut into hole with plus nut tool attached.
- Using the 9/16" box wrench, hold the plus nut tool stationary and then tighten hex head bolt until plus nut is tightly gripping and does not spin when hex bolt is loosened.
- DO NOT overtighten plus nut.
- Using the 9/16" box wrench, hold the plus nut tool stationary to remove the

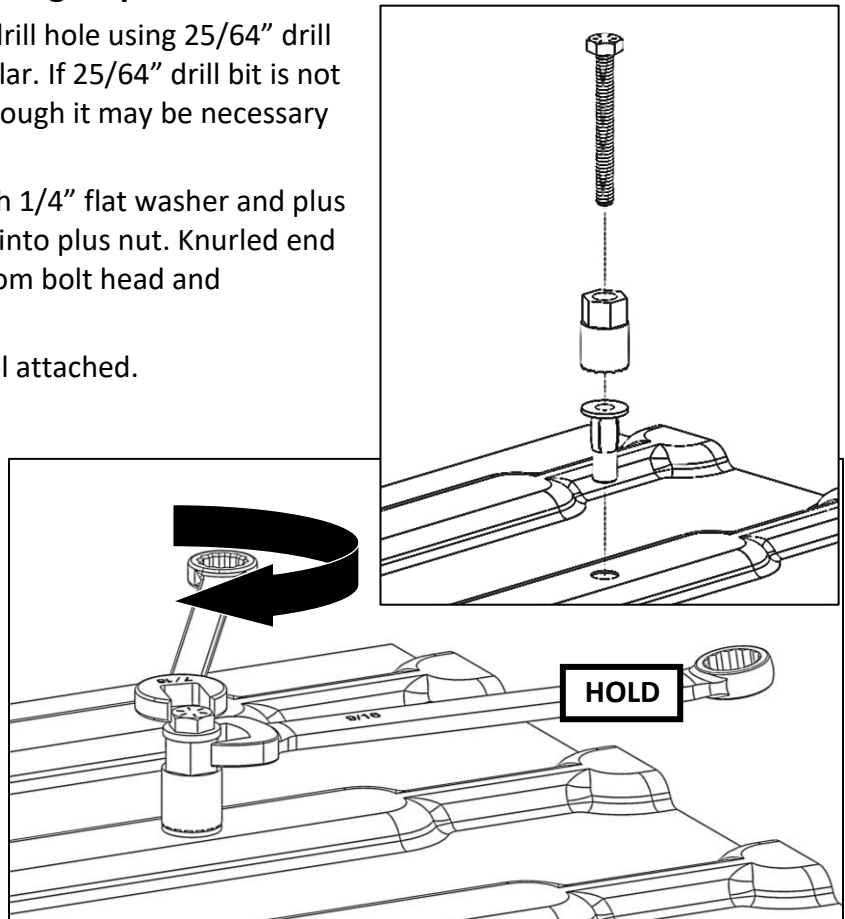

## Step 5P – Install Data File

- Place assembled driver data file in position.
- Using two 1/4" x 1-1/4" hex head bolts, 1/4" lock washers, and 1/4" flat washers, secure rear mounting bracket to plus nuts installed in floor.
- Using one 1/4" x 1-1/2" self-drilling sheet metal screw, a 1/4" lock washer, and a 1/4" flat washer, secure front bracket to floor. **DO NOT OVERTIGHTEN SHEET METAL SCREW.**

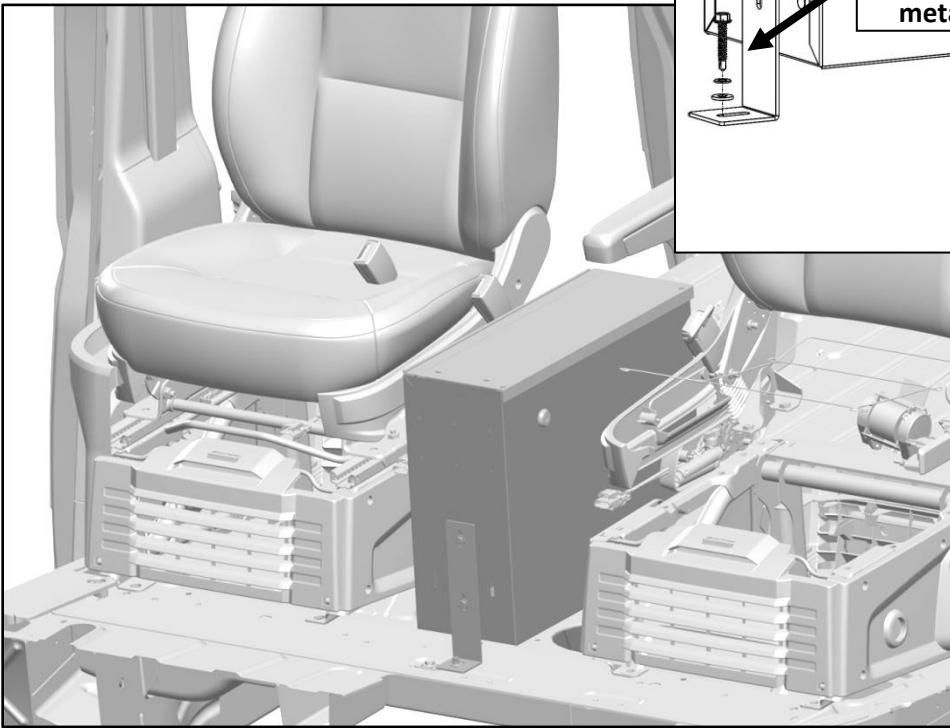
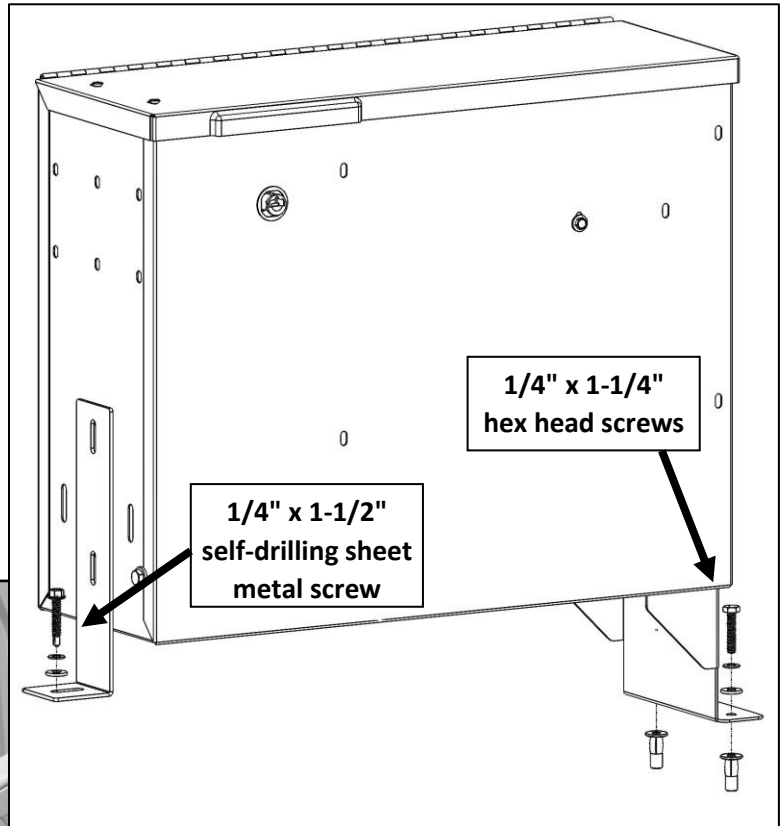

## Step 6P – Finish Installation

- Align and square data file.
- Tighten all bolts from previous steps. **DO NOT OVERTIGHTEN SHEET METAL SCREW.**

**YOUR INSTALLATION IS NOW COMPLETE.**