

Holman

Instruction Guide 40238

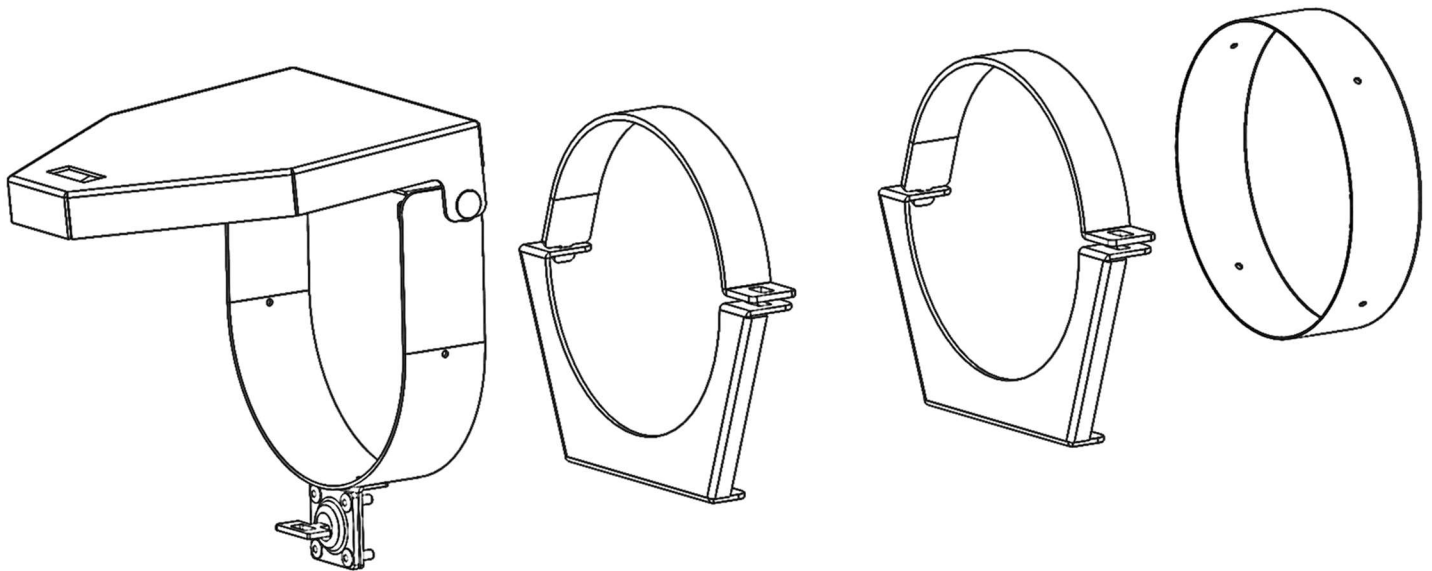

Holman

Rancho Cordova, CA 95742

800-343-7486

InstallationSupport@Holman.com

PLEASE READ ALL INSTRUCTIONS AND WARNINGS PRIOR TO ASSEMBLING, INSTALLING, AND USING THIS PRODUCT.

Warning



Always check for wires, fuel tanks and lines, brake lines and other important vehicle functionality items prior to drilling and installing all products.



DO NOT EXCEED MANUFACTURERS WEIGHT CAPACITY FOR ROOF.

Tools Needed

1/2" Socket and Wrench	1/2" Box Wrench
Sealant	3/16 Drill Bit
Drill	21/64" Drill Bit
Rivet Gun	

Table of Contents

Parts List 1

Hardware..... 2

Step 1 – Ensure Appropriate PVC Length 3

Step 2 – Install Door Cap 3

Step 3 – Install End Cap..... 4

Step 4 – Attach Clamp Bracket to Conduit Carrier..... 5

Step 5 – Mount Rack..... 6



Before You Begin

- Read all instructions prior to installing any Holman product.
- Have PVC tubing ready for installation. It is best to smooth edges on PVC before assembly.

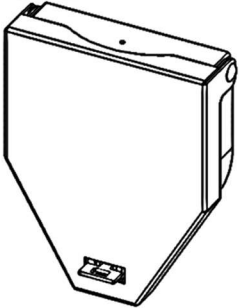

Parts List

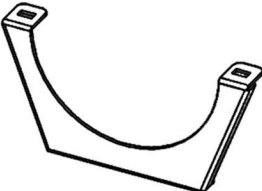
ITEM NO.	ITEM	PART NUMBER	DESCRIPTION	QTY.
1		40238-11	Cap Assembly	1

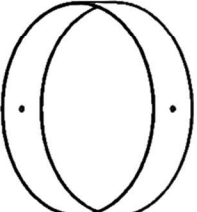
Parts List (Continued)

ITEM NO.	ITEM	PART NUMBER	DESCRIPTION	QTY.
2		40238-20-002	Clamp Bracket	2
3		40238-20-003	Clamp	2
4		40238-20-005	Round Cap	1
5		18-40238		1

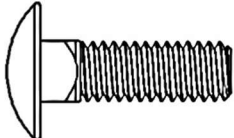
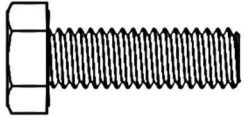
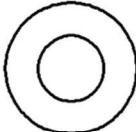
Hardware

ITEM	HARDWARE TO SCALE	PART NUMBER	DESCRIPTION	QTY.
1		21811	5/16-18 X 1" CARRIAGE BOLT	6
2		11241179	5/16-18 X 1" HEX HEAD BOLT	4
3		33080	5/16" WASHER	10
4		0169777	5/16"-18 NYLOC	6
5		0125939	3/16" DIA STEEL BLIND RIVET	8

DO NOT EXCEED MANUFACTURERS WEIGHT CAPACITY FOR ROOF.

Step 1 – Ensure Appropriate PVC Length

- Measure the length of materials to be stored in conduit carrier. Purchase or cut PVC with enough room at each end to properly store materials and assemble conduit carrier.

Step 2 – Install Door Cap

NOTE: Be sure to use the factory finished end of PVC tubing to install door cap to. If you must use a cut end of PVC tubing, ensure cut end is cut straight and flat.

- Slide door cap assembly over factory finished end of PVC tubing until PVC tubing is flush with outside edge of bracket.
- Using a 3/16" drill bit, drill through each of the four holes in door cap, also through the PVC.
- Apply sealant into each hole drilled.
- Insert blind rivets into each hole and rivet end cap to PVC. **We recommended install bottom most rivet from inside the PVC pointing outward.**
- Wipe away excess sealant.

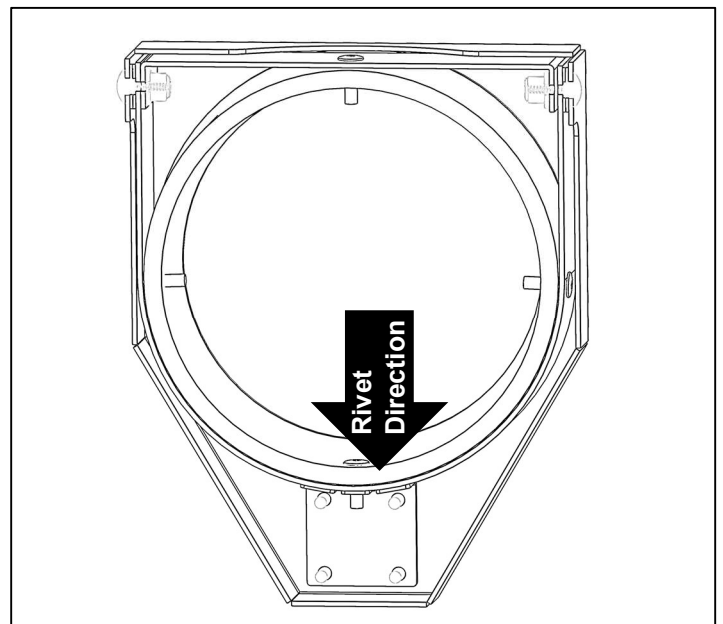
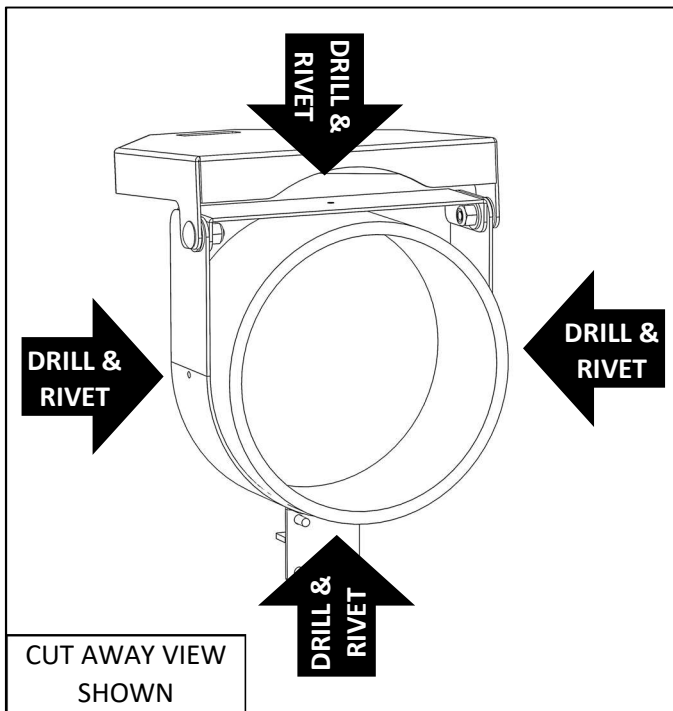
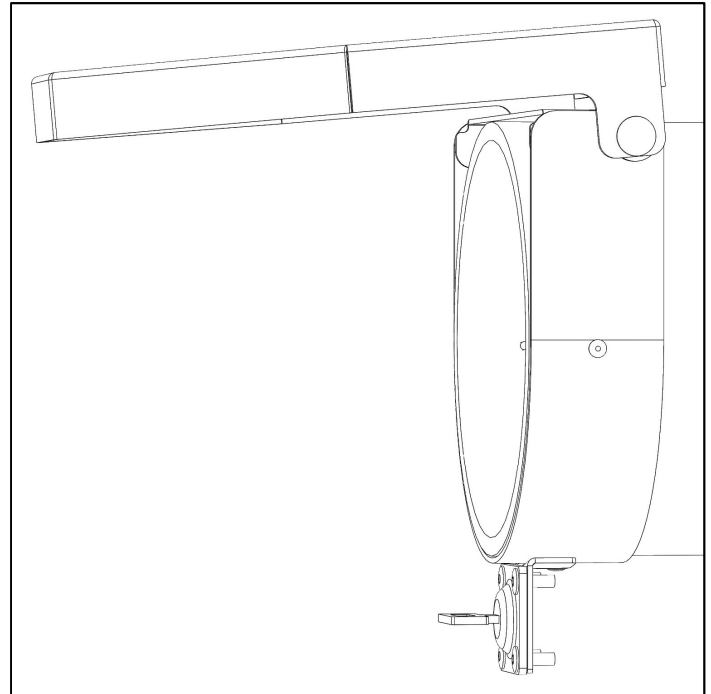

Step 3 – Install End Cap

- Close and latch door at opposite end of conduit carrier.
- Insert a sample piece of material to be stored in conduit carrier.
- Apply sealant around entire inside diameter of end cap.
- Slide end cap over PVC with cap turned so that holes in cap are at 45°, 135°, 225°, and 335° from vertical.

Be sure to allow enough room so end cap is not tight against sample material inside.

- Using a #11 drill bit, drill through each of the four holes in end cap and through the PVC.
- Apply sealant into each hole drilled.
- Insert blind rivets into each hole and rivet end cap to PVC.
- Wipe away excess sealant.
- Remove sample material.

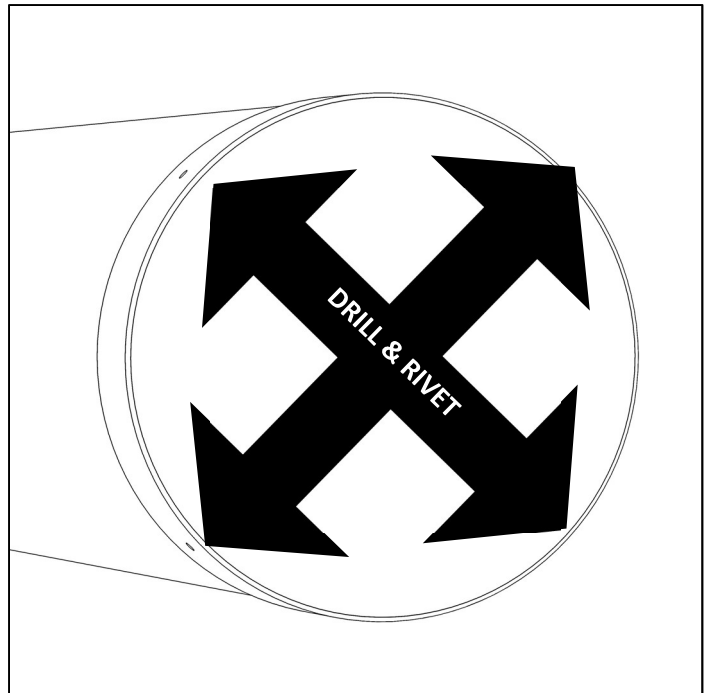
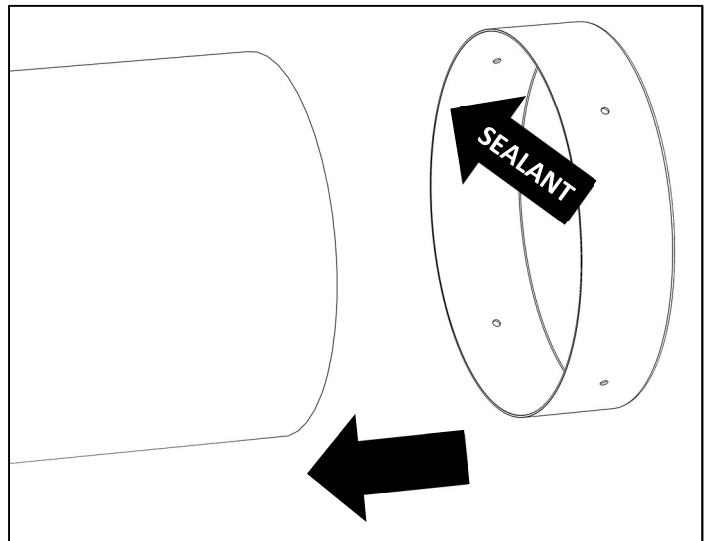

Step 4 – Attach Clamp Bracket to Conduit Carrier

- Turn clamp about 90 degrees to clamp bracket, insert mushroom hooks on clamp into slots on clamp bracket, and then turn back.

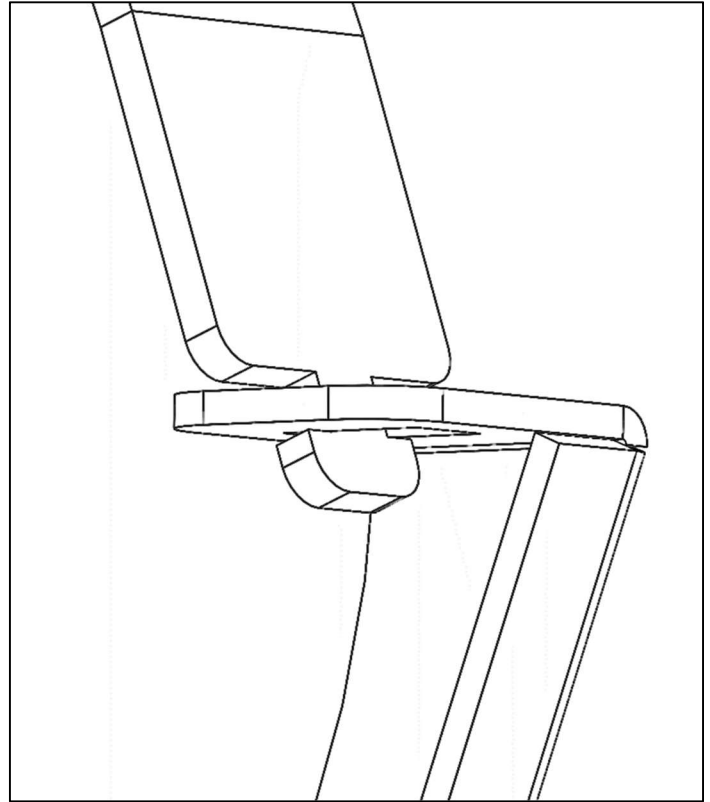
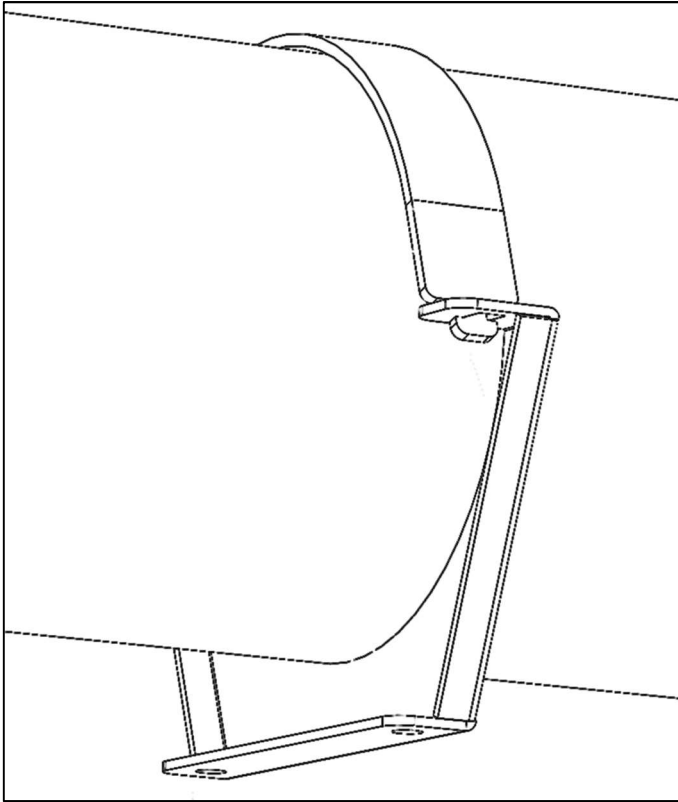

- Using one 5/16" x 1" carriage bolt, one 5/16" washer, and one 5/16" lock nut, LOOSELY bolt clamp and clamp bracket together around PVC.
- Repeat for second clamp.

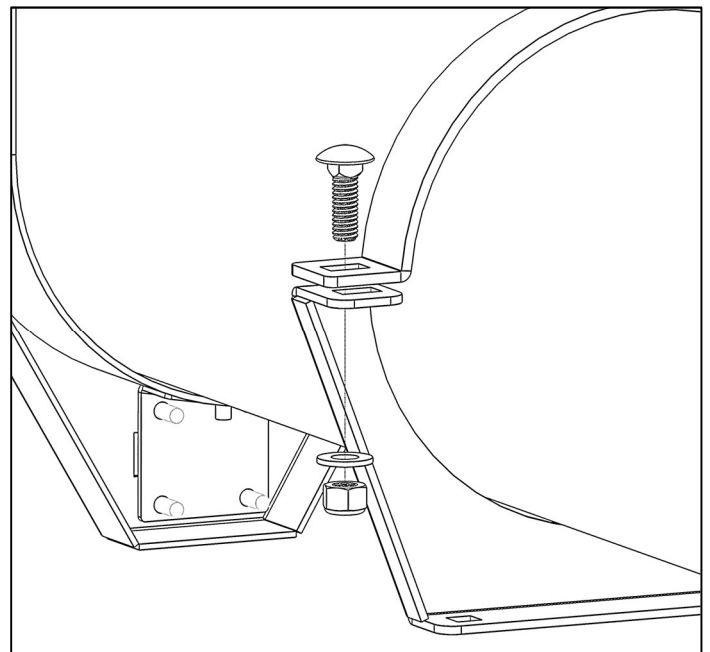

Step 5 – Mount Rack

- Determine desired location on rack to mount conduit carrier. When using conduit carrier with double-sided drop down or double-sided clamp and lock racks, it is recommended to center the conduit carrier side to side.

Note: If desired location has square holes use provided 5/16" X 1" carriage bolts.



Be sure conduit carrier in position does not interfere with operation of any rack mechanism, swing handle, or installed equipment.

- Holding the clamp bracket in position, mark through holes in clamp bracket onto rack.



When installing hardware through any installation surface, always ensure the area behind the installation surface is clear of electrical wiring, fuel tank or lines, or any vehicle safety features. Use a drill stop to keep from drilling through van roof.

- Using a 21/64" drill bit, drill through rack at each marked location.
- Using two 5/16" x 1" hex head bolts, four 5/16" washers, and two 5/16" lock nuts, loosely bolt each clamp bracket to the rack.
- Tighten all hardware.

GO BACK AND ENSURE ALL HARDWARE IS TIGHTENED.

ASSEMBLY AND INSTALLATION ARE COMPLETE.

