

Holman

Assembly Guide 40020

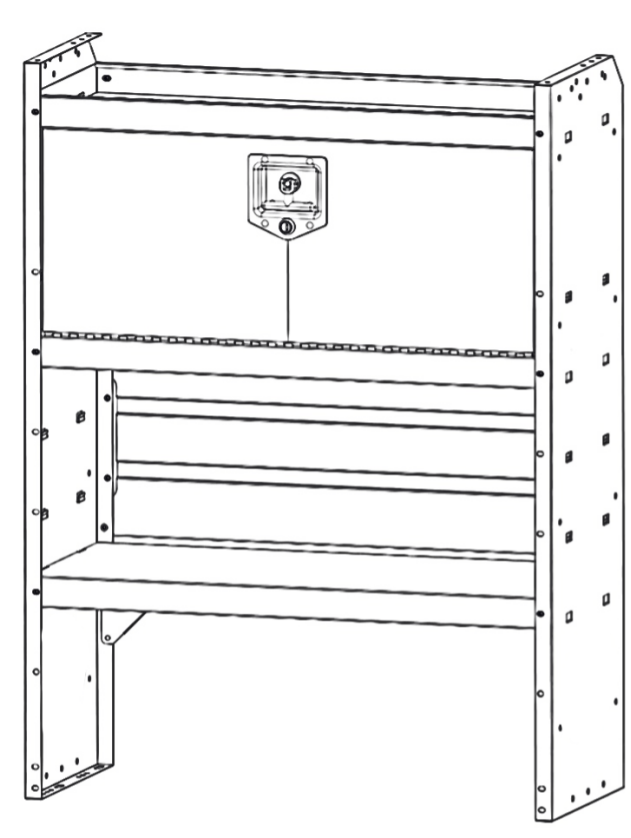

Holman
Rancho Cordova, CA 95742
800-343-7486
InstallationSupport@Holman.com

*** PLEASE READ ALL INSTRUCTIONS AND WARNINGS PRIOR TO ASSEMBLING, INSTALLING, AND USING THIS PRODUCT. ***

Warning



Always check for wires, fuel tanks and lines, brake lines and other important vehicle functionality items prior to drilling and installing all products.

Tools Needed

7/16" Wrench and Socket	#2 Phillips driver
-------------------------	--------------------

Table of Contents

Parts	2
Hardware	2
Step 1 – Determine Location of Door Kit	3
Step 2 – Bolt Door to Shelf Below	3
Step 3 – Determine Locking Door Stop Orientation	4
Step 4 – Attach Locking Door Stop to Shelf Above.....	4



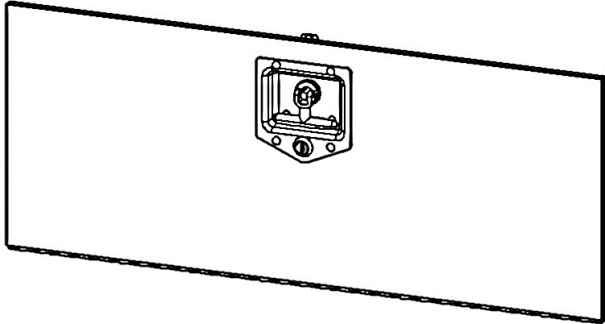
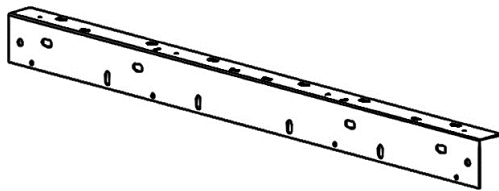

Before You Begin

- Be sure to have 32" shelf assembled prior to door kit installation.
- Some images in the following instructions show using 42" shelf. Instructions are the same for the 32" shelf.

Parts

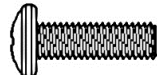
ITEM NO.	40020 PARTS	DESCRIPTION	QTY.
A		32" Door Panel ASM	1
B		32" Locking Door Stop	1

Hardware

ITEM NO.	Hardware To Scale	DESCRIPTION	QTY.
1		10-32 x .625 PH Phillips Drive	8
2		10 Flat Washer	8
3		10-32 Flanged Nyloc Nut	8
4		.156 x .375 bumper	4

Step 1 – Determine Location of Door Kit

- Decide where you want the door kit to be installed. Be sure there is the correct spacing between shelves. The bottom shelf of the desired opening must have the shelf lip facing downward.
- Bottom position can only be used with purchase of additional 32" floor lip (48215).
- Standard shelf placing and orientation shown.

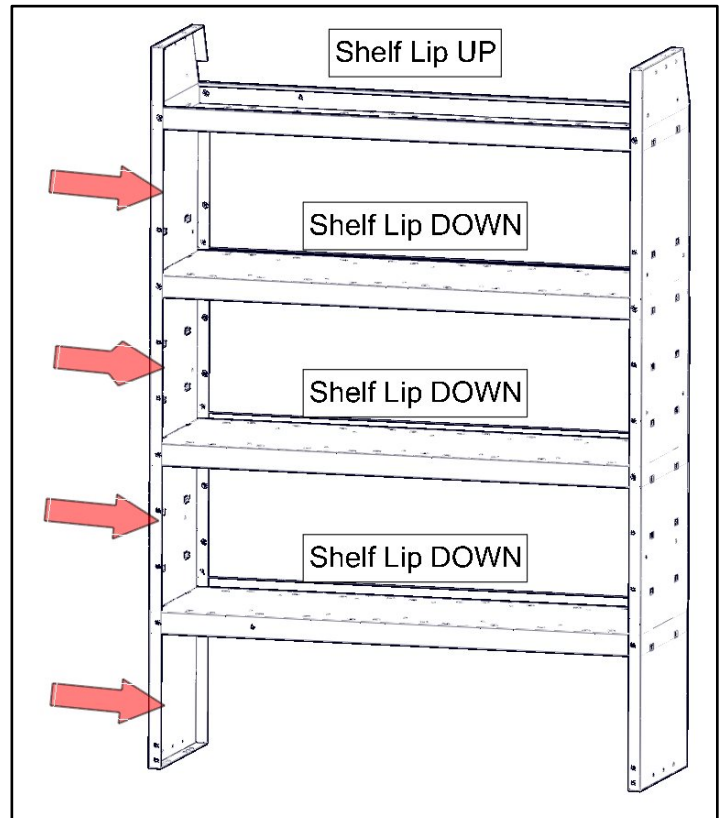

Step 2 – Bolt Door to Shelf Below

- Bolt door kit to flat space on shelf below using a #10 x 5/8" machine screw, a #10 flat washer, and a #10 flanged lock nut.
- Repeat 3 more times along shelf and door kit assembly.
- Be sure when the door kit is folded up, it sits flush with the outside of the shelf.
- Snug tighten but allow for movement.

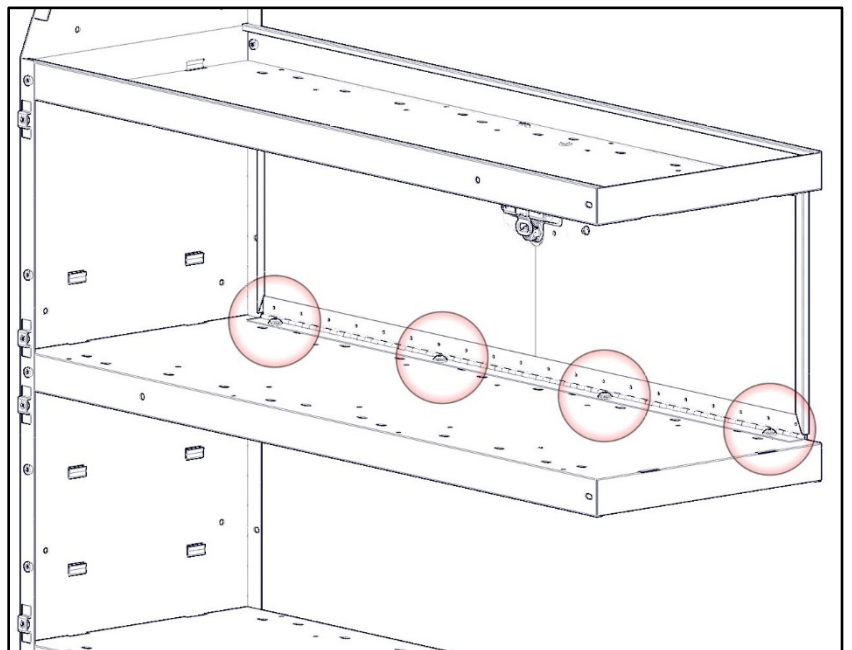
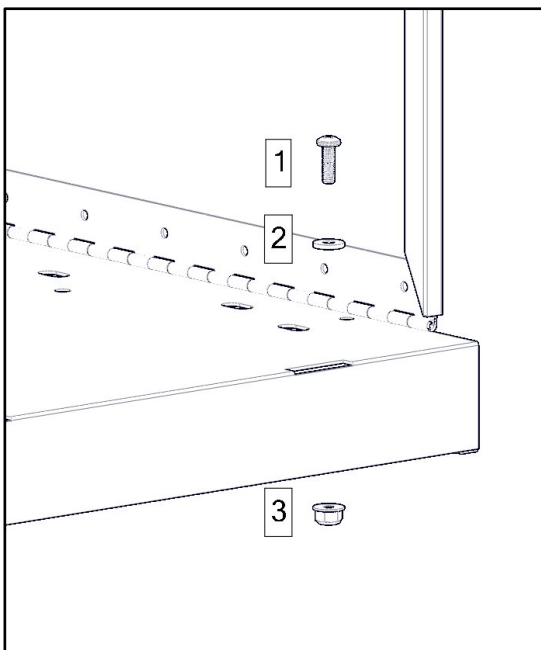

Step 3 – Determine Locking Door Stop Orientation

- Locate the shelf that is directly above the shelf used in the previous step.
- Determine if it is an upward or downward facing shelf lip. This will determine orientation of door stop.

Facing Upwards

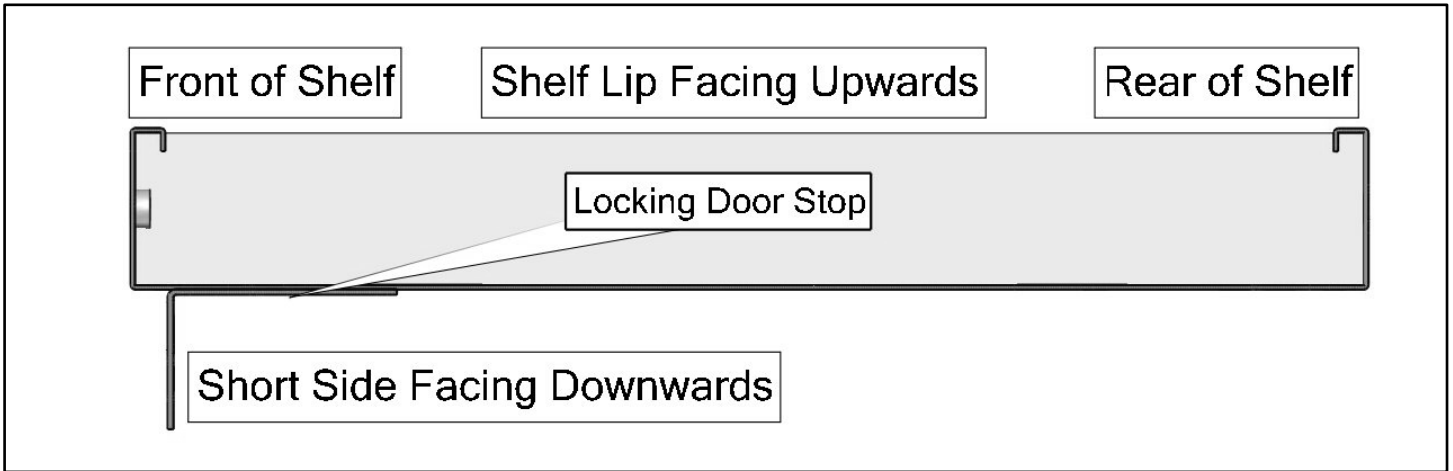

Facing Downwards

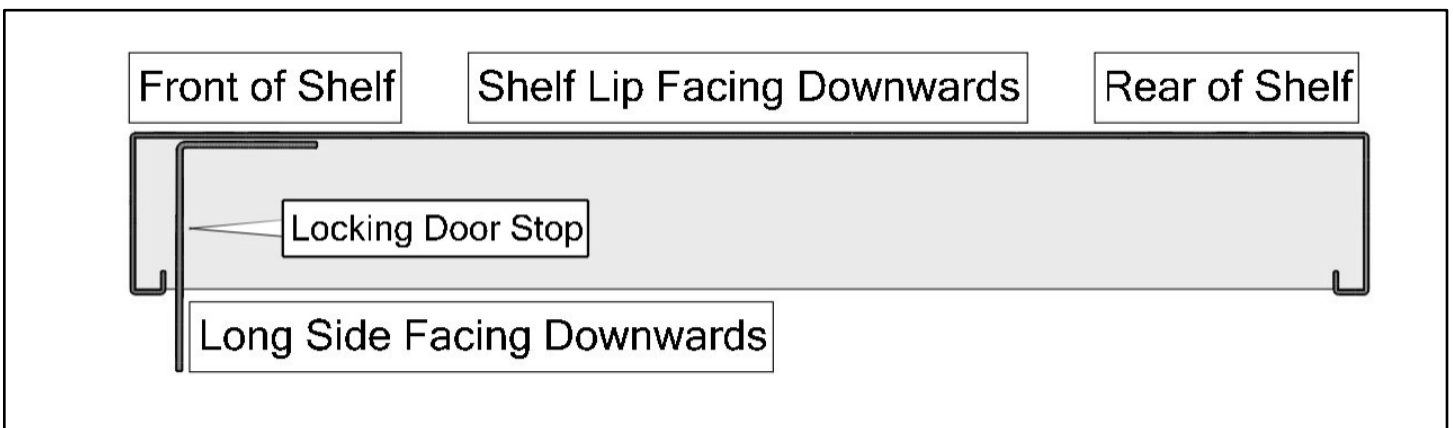

Step 4 – Attach Locking Door Stop to Shelf Above

- Bolt locking door stop to bottom of shelf using using a #10 x 5/8" machine screw, two #10 flat washers, and a #10 flanged lock nut.
- Snug tighten but allow for movement.

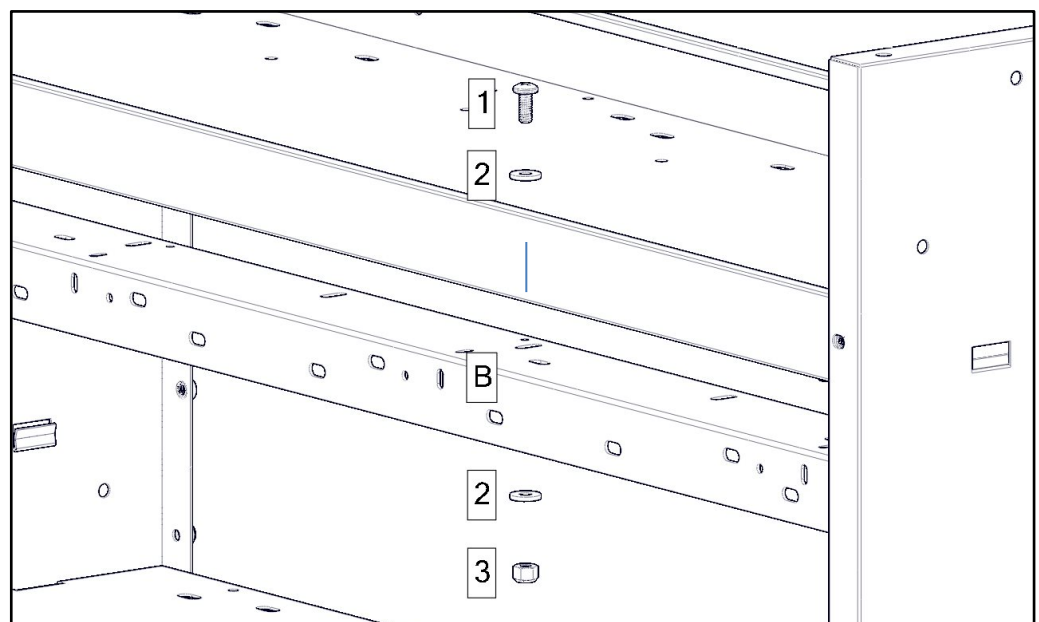

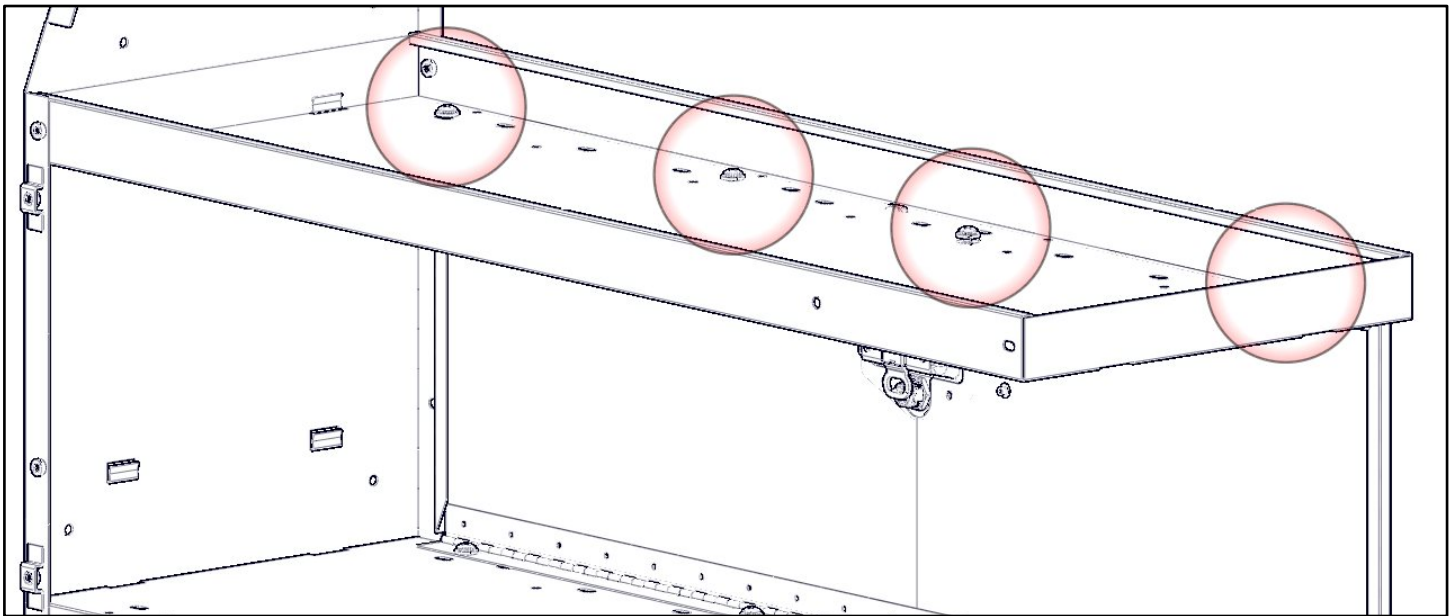

- Repeat 3 more times along shelf and locking door stop.
- Insert rubber bumpers in holes along locking door stop where they will encounter the door.

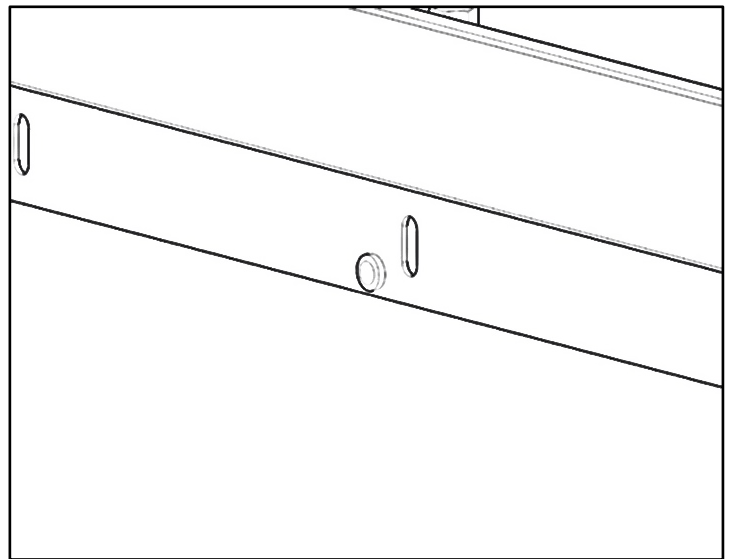
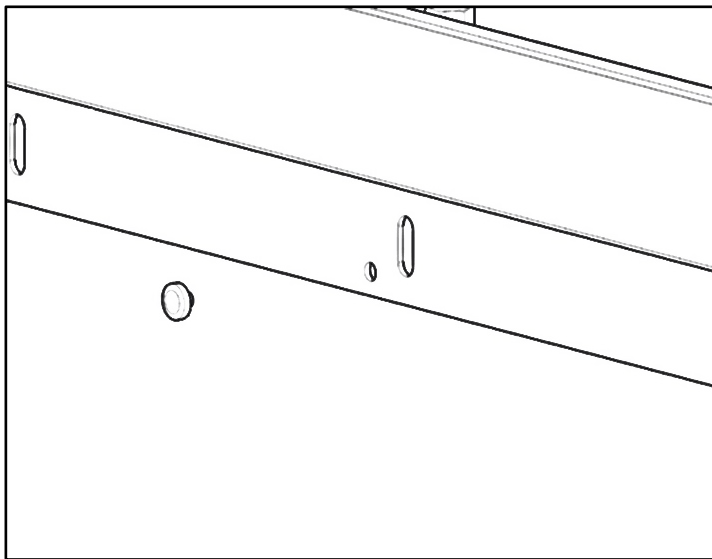

**GO BACK AND TIGHTEN ALL
HARDWARE.**

**YOUR INSTALLATION IS NOW
COMPLETE.**

