

Holman

Installation Guide Pro Forklift Service Body Rack

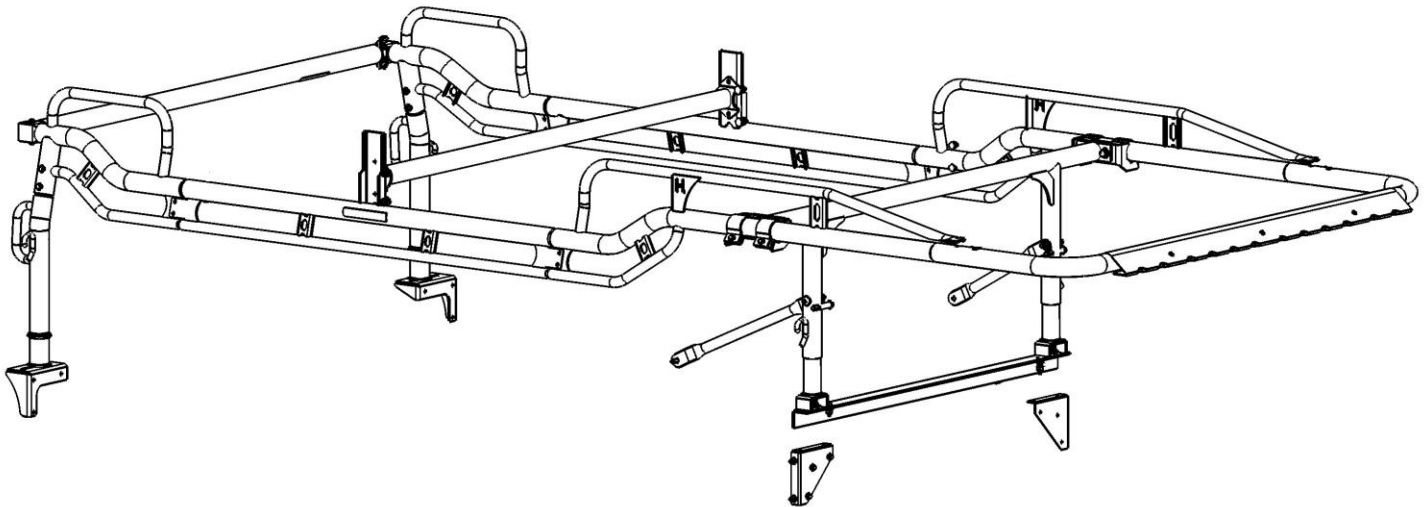

Holman
Rancho Cordova, CA 95742
800-343-7486

InstallationSupport@Holman.com

PLEASE READ ALL INSTRUCTIONS AND WARNINGS PRIOR TO ASSEMBLING, INSTALLING, AND USING THIS PRODUCT.

WARNING



Always check for wires, fuel tanks and lines, brake lines and other important vehicle functionality items prior to drilling and installing all products.



Too much weight will greatly reduce the stability of your vehicle. Holman makes no representation or warranty as to the amount of weight your vehicle can safely carry. For guidance, we recommend that you consult the vehicle manufacturer. At no time should the weight of the vehicle, rack, driver, passengers and cargo loaded on a Holman rack exceed either the Gross Vehicle Weight Ratio (GVWR) or the Gross Axle Weight Ratio (GAWR) as specified by the vehicle manufacturer.



Do not use your rack with the rear cross bar removed. Removal of rear crossbar will affect structural integrity of the rack.



Secure all payloads properly for safe transportation.

Tools Needed

1/2" 9/16", 3/4" Box Wrenches	1/2", 9/16", 3/4" Sockets and Wrench
7/32", 5/16" Allen Wrenches	Drill
11/32", 13/32" Drill Bits	Drill Bit Stop Collar



Before You Begin

1. Read all instructions carefully, and follow each step in proper sequence, for ease and speed in assembling your Holman rack.
2. The “bulkhead” is the panel at the front of the service body. Measure the distance from the top of the bulkhead to the top of the truck’s cab. This distance should be in the range of 15” to 22”.
3. **PROPER SEALANT APPLICATION IS CRITICAL TO PREVENTING WATER PENETRATION INSIDE THE RACK.** Apply a healthy bead of sealant entirely around every swaged joint and every bolt going through tubing. Improper sealing can lead to water penetration and rust on inside surfaces.

4. Standard mounting is on the rear panel. Check to ensure the rear panel of the service body is free of taillights or other obstructions (inside or out) in the area where the rear legs of the rack bolt to the body. Consult sketch below.
- There must be open unobstructed space at least 1-3/4" above taillight and below flip top box lid.
 - There must be open unobstructed space at least 1-1/4" to the left or right of taillight.
 - The distance between the crown of the roof plus 2-1/2" to the top of the mount bracket must be no greater than 24-1/2". If the distance is greater than 24-1/2", the optional 9" extension kit (31520) is required.
 - The service body foot must be mounted as close as possible to the vertical exterior corner of the rear body panel. If mounting to the vertical exterior corner of the rear body panel is not possible, the right and left service body rear feet can be switched and the feet can be mounted as close as possible to the vertical interior corner of the rear body panel.

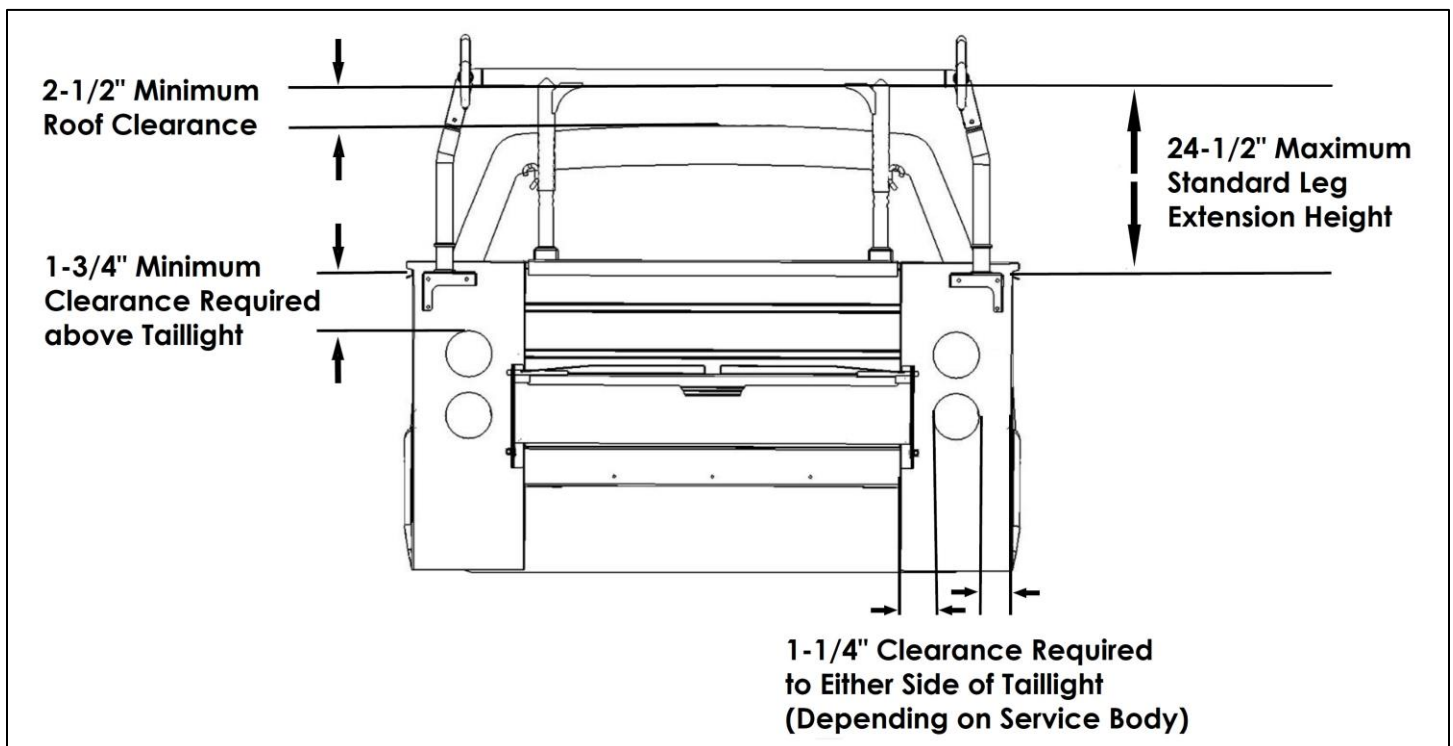

DON'T OVERLOAD YOUR VEHICLE!

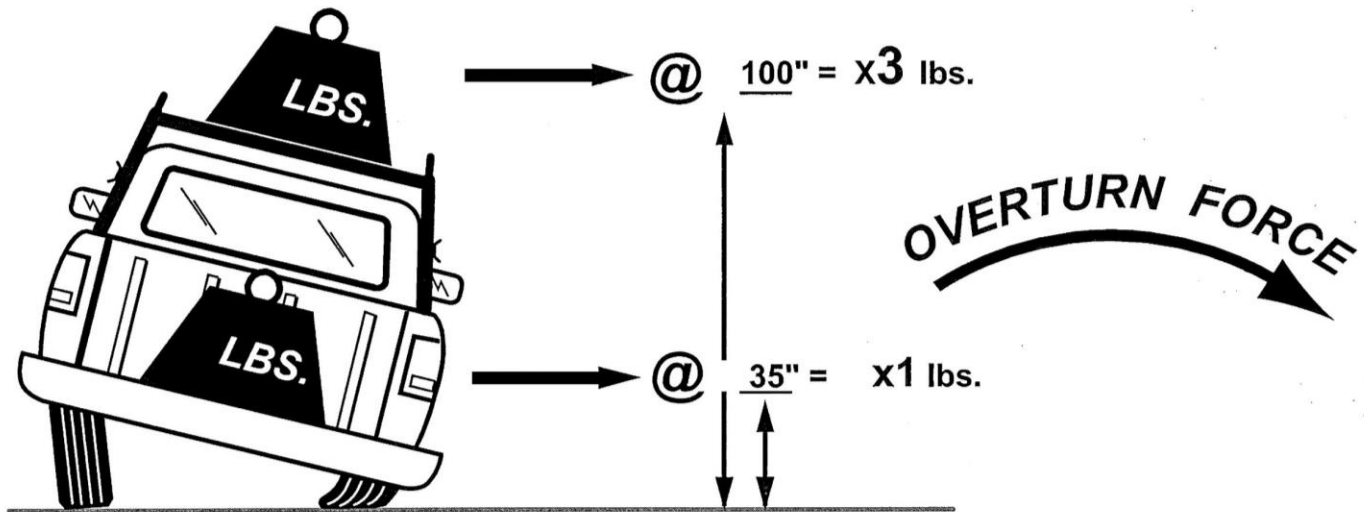

WEIGHT CARRIED ABOVE THE FLOOR OF THE TRUCK BED (E.G. ON AN OVERHEAD TRUCK RACK) WILL SIGNIFICANTLY INCREASE THE VEHICLE'S TENDENCY TO OVERTURN. ALWAYS KEEP HEAVY LOADS EVENLY DISTRIBUTED AND AS LOW AS POSSIBLE. IT IS IMPORTANT TO NOTE THAT THE HOLMAN RACK LOAD BEARING CAPACITY OF 1700 LBS. MAY BE GREATER THAN YOUR TRUCK'S GAWR OR GVWR CAPACITY, AND IS PROBABLY GREATER THAN THE WEIGHT THAT CAN BE SAFELY CARRIED OVERHEAD. RETIGHTEN ALL BOLTS AFTER FIRST USE, PERIODICALLY CHECK BOLTS FOR TIGHTNESS.

For *TECHNICAL SUPPORT* Call:











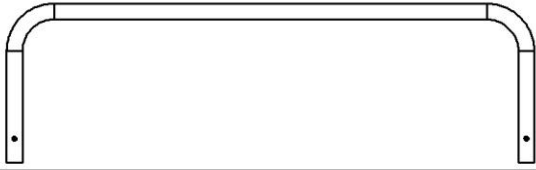
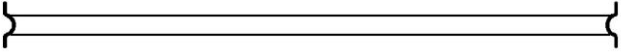

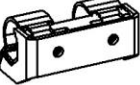
1.800.343.7486

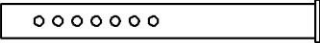
or email: InstallationSupport@Holman.com

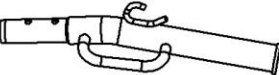
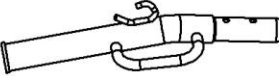
Table of Contents

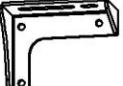
Leg and Bar Kit Parts List	5
Hardware Kit	7
Hardware (Continued)	8
Sealant Application	9
Step 1 – Measure Service Body and Truck	9
Step 2 – Install Front Leg Angle Mount	10
Step 3 – Install Bulkhead Bracing	10
Step 4 – Assemble Front Leg Assembly	11
Step 5 – Join Side Channels	11
Step 6 – Attach Wind Deflector	12
Step 7 – Attach Front Tube	13
Step 8 – Attach Center Crossbar	13
Step 9 – Attach Rear Take-out Bar	13
Step 10 – Attach Rear Legs	14
Step 11 – Attach Front Legs	14
Step 12 – Install Foot to Rack	16
Step 13 – Install Rack onto Service Body	17
Step 14 – Install Support Arm	18
Step 15 – Tighten Hardware	18
Troubleshooting	19
Rear Take-out Bar Position Lock	19
Adjust Wind Deflector	19
Install Extra Crossbar	20

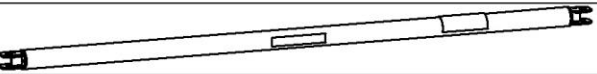
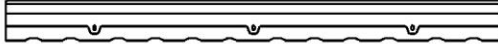
Leg and Bar Kit Parts List



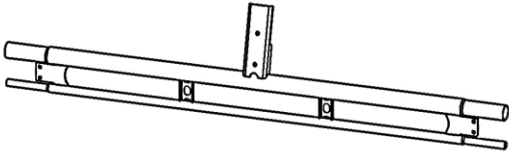
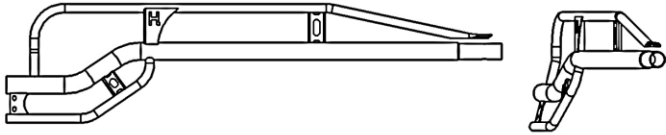
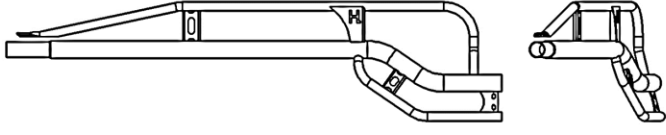
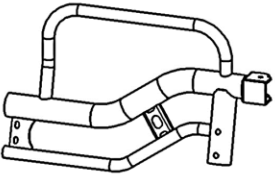
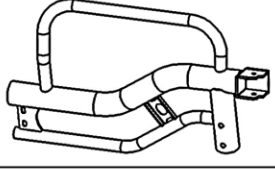
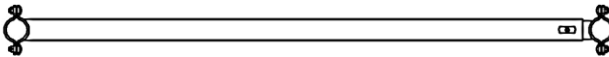

NO.	ITEM	PART NUMBER	DESCRIPTION	QTY.
1		11-00004	FRONT TUBE FS	1
2		101669	CENTER CROSSBAR	1
3		101429	FRONT LEG ANGLE MOUNT	1
4		101220	CROSSBAR STRAPPING BRACKET	2
5		101431	FRONT SB LEG ASSY, FORKLIFT	1
6		13-00659-R2	SERVICE BODY TELESCOPING LEG	2
7		11-00757	SERVICE BODY SUPPORT ARM	2
8		101184	REAR LEG ASSEMBLY, FS SB, RH PS	1
9		101408	REAR LEG ASSEMBLY, FS SB, LH DS	1
10		70020-10-004	SERVICE BODY FOOT, REAR RH	1
11		70020-10-003	SERVICE BODY FOOT, REAR LH	1
12		70020-10-010	CORNER SUPPORT	2
13		70020-16	3-1/2" LEG EXTENSION, 2" OD	2
14		101170	Rear Take-out Bar, 64.5"	1
15		101415	PRO RACK WIND DEFLECTOR, 52", 2" TUBING, STEEL	1
16		101404	WIND DEFLECTOR STRAP	3
17		18-12004	HARDWARE KIT	1

Side Channel Parts List



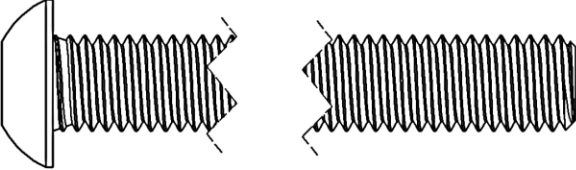
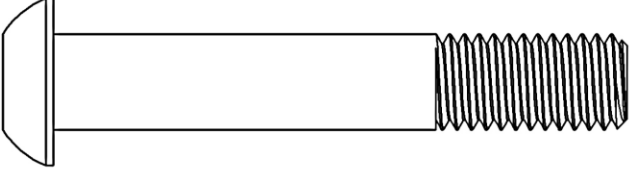
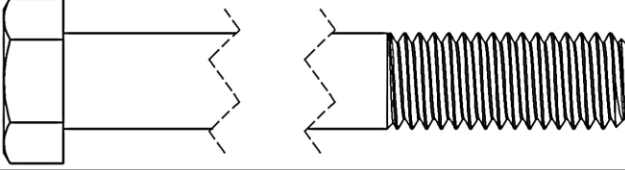

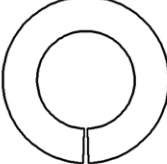
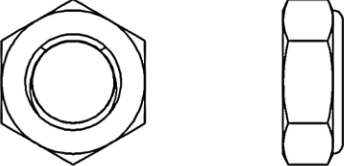
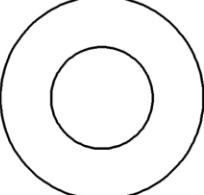
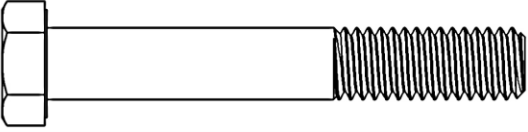

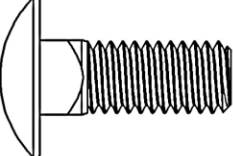

NO.	ITEM	KIT: PART NUMBER	DESCRIPTION	QTY.
1		12200, 12201: 101218 12202, 12203, 12204: 101193 12205, 12206: 101172	EXTENSION SIDE CHANNEL, 52"	2
2		12200, 12203, 12206: 101224 12201, 12204: 101693 12202, 12205: 101144	FRONT SIDE CHANNEL. MULTIPOSITION, RH, PS	1
3		12200, 12203, 12206: 101225 12201, 12204: 101692 12202, 12205: 101149	FRONT SIDE CHANNEL. MULTIPOSITION, LH DS	1
4		101163	REAR LEG CHANNEL, RH PS	1
5		101166	REAR LEG CHANNEL, LH DS	1
6		31110*	PRO II EXTRA CROSSBAR	1

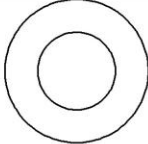
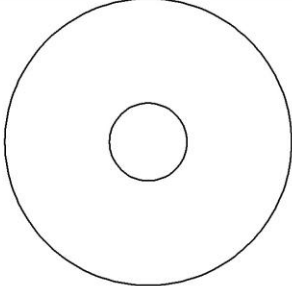
* Extra crossbar is included in extended and crew cab kits only.

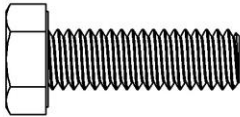
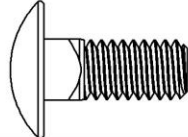
Hardware Kit

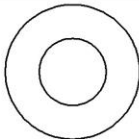
ITEM	HARDWARE TO SCALE	PART NUMBER	DESCRIPTION	QTY.
1			1/2"-13 X 3-1/4" BUTTON HEAD SCREW	2
2		42KD91	1/2"-13 X 3" BUTTON HEAD CAP SCREW	4
3		11241240	1/2"-13 X 4-1/2" HEX HEAD BOLT	2
4		11241379	1/2-13 X 1-1/4" HEX HEAD BOLT	8
5		1133626	1/2" LOCK WASHER	8
6		37695	1/2"-13 THIN LOCKING JAM NUT	4
7		11541086	1/2" WASHER	14
8		11137260	3/8-16 X 2-1/2" HEX HEAD BOLT	5
9		73815	3/8"-16 X 1-1/4" BUTTON HEAD HEX KEY SCREW	10
10		74436	3/8-16 X 1" CARRIAGE BOLT	4

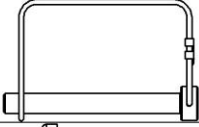
Hardware (Continued)

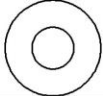
ITEM	HARDWARE TO SCALE	PART NUMBER	DESCRIPTION	QTY.
11		0169791	3/8"-16 LOCK NUT	10
12		0159723	3/8" WASHER	28
13			3/8" X 1.5" OD X .08" THK OVERSIZED WASHER	6
14			3/8"-16 JAM NYLOCK NUT	9
15		11241179	5/16-18 X 1" HEX HEAD BOLT	14
16		21810	5/16"-18 X 3/4" CARRIAGE BOLT	8
17		0169777	5/16"-18 NYLOC	18
18		90126A030	5/16" FLAT WASHER	32
19		11104019	5/16-18 FLANGED NYLOCK NUT	4
20	 NOT TO SCALE	98416A575	3/8" X 2-7/8" WIRE LOCK CLEVIS PIN	1
21			#10-32 X 3/4" BUTTON SCREW	3
22			#10 FLAT WASHER	3
23		-	ADHESIVE SEALANT	1

Sealant Application



Proper sealant application is critical to preventing water penetration inside the rack.

- Apply a healthy bead of sealant around every swaged joint as shown. Improper sealing can lead to water penetration and rust on inside surfaces.

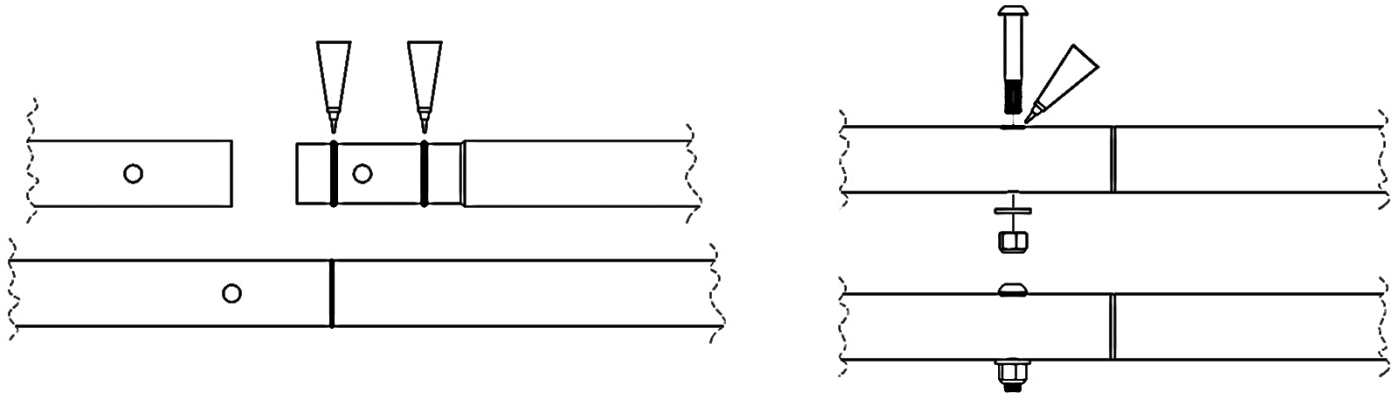

- Wipe any excess sealant off immediately with a plastic scraper or paper towel. Any smeared sealant can be rubbed off as soon as sealant dries.
- **Maintain this seal throughout the life of your rack.**
- Repeat process for opposite side.

Step 1 – Measure Service Body and Truck

- Measure distance between inside of service body bulkhead to rear of service body.
- Measure and record height from bulkhead to top of vehicle.
- Crossbars will need to be 2-1/2" or more above the roof.

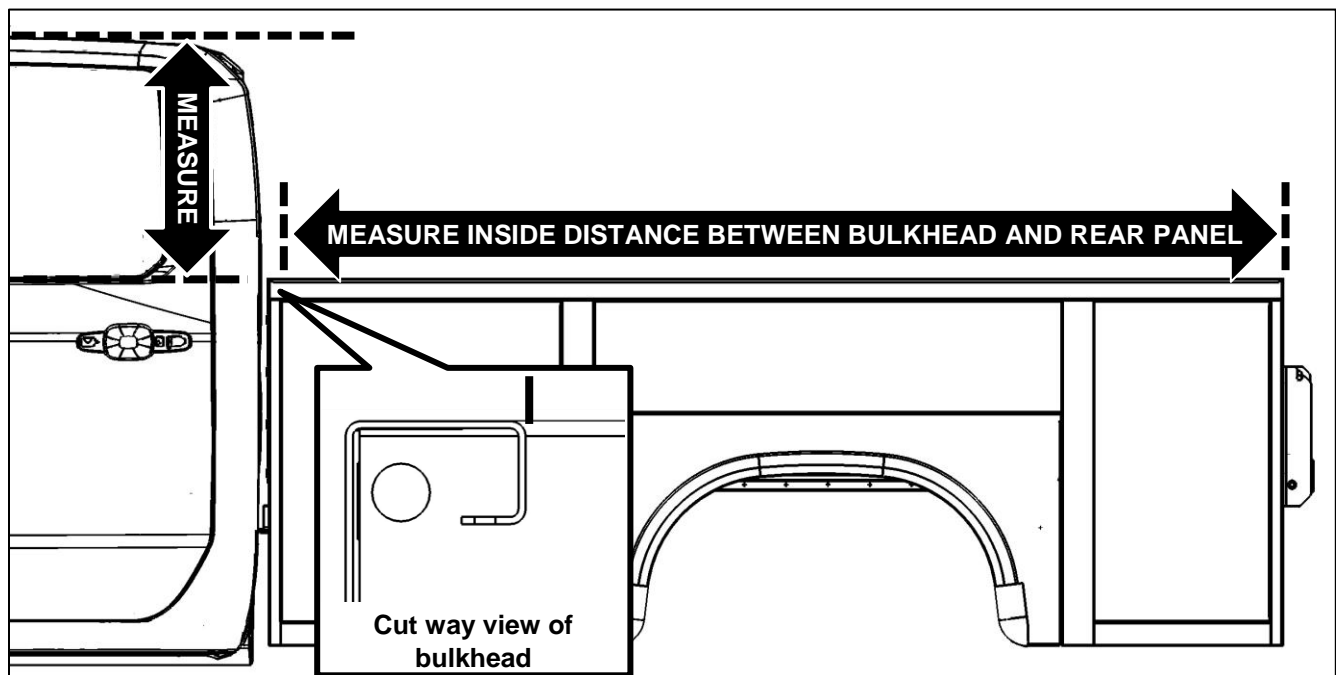

Step 2 – Install Front Leg Angle Mount

- Set front leg angle mount on top of the bulkhead, with flat face towards the rear.
- Center angle mount side-to-side.
- Mark location of holes in angle mount onto bulkhead.

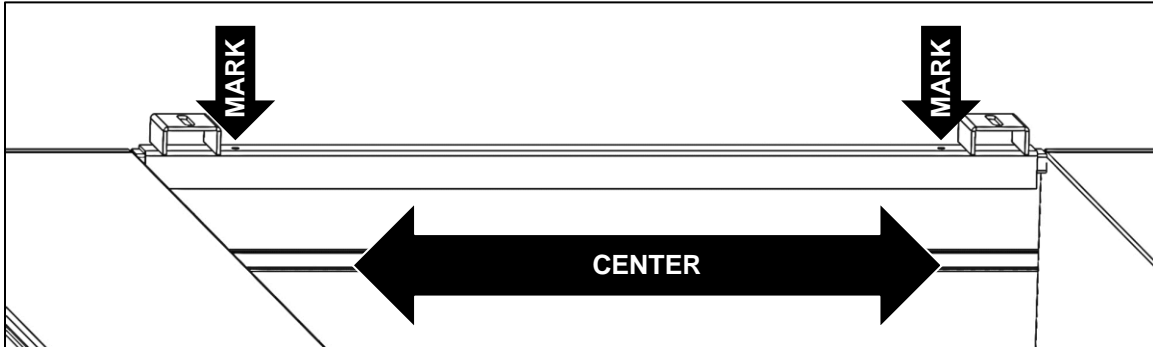

- Remove front leg angle mount.
- Using a 13/32" drill bit, drill a hole in the top of the bulkhead where marked.



Be sure drilling location is clear of wires, fuel tanks and lines, brake lines and other important vehicle functionality items.

- Using one 3/8" button head screw, two 3/8" washers, and one 3/8" lock nut, install angle mount to service body bulkhead.

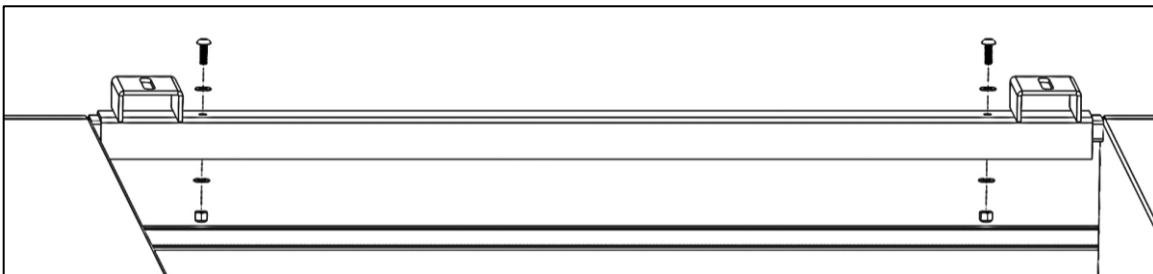

Step 3 – Install Bulkhead Bracing



We recommend the following additional bracing be added to the service body bulkhead to support the truck rack. Some service bodies are not structurally designed to support loads upon the bulkhead without additional bracing.

- Place the corner support against the inside of the bulkhead, against the top right side of the bulkhead flange or rail. The support should be touching three service body panels.
- Mark the location of the three holes against the bulkhead and the two holes to the service body interior sidewall.
- Repeat for the opposite side.

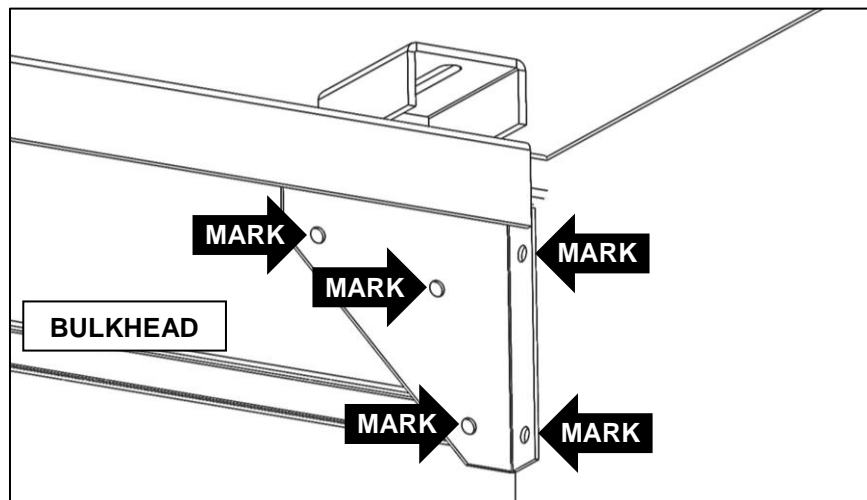

- Using an 11/32" drill bit, drill a hole in each location marked.



Be sure drilling location is clear of wires, fuel lines, brake lines and other important vehicle functionality items. Use a drill bit stop collar.

- Apply some sealant around each hole drilled into side compartment.
- Using one 5/16" bolt, two 5/16" washers, and one 5/16" lock nut for each hole drilled, attach the corner support to the service body.
- Repeat on opposite side.

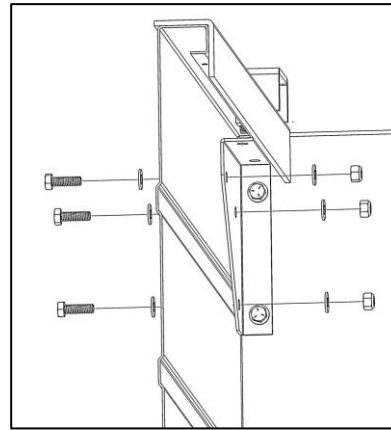
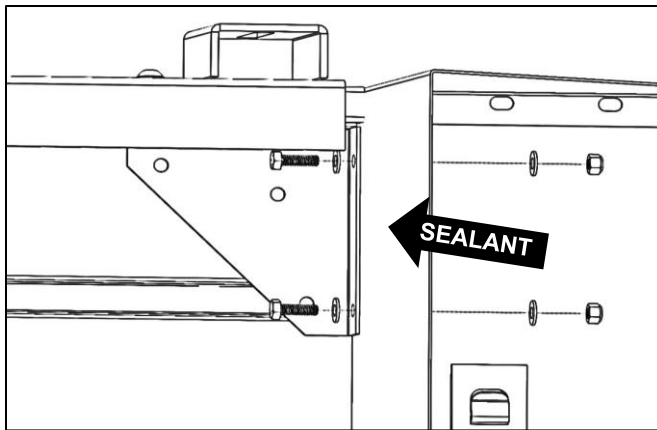

Step 4 – Assemble Front Leg Assembly

- Insert telescoping leg into leg assembly.
- Position leg so the bottom of telescoping leg is **AT LEAST 1/2" more** than the height between service body bulkhead and roof peak measured earlier.
- Align holes and **LOOSELY** fasten each leg to the leg assembly using a 1/2" x 3-1/4" button head screw, two flat washers, and 1/2" jam nut. For most installations, it is best to install bolts facing inward.

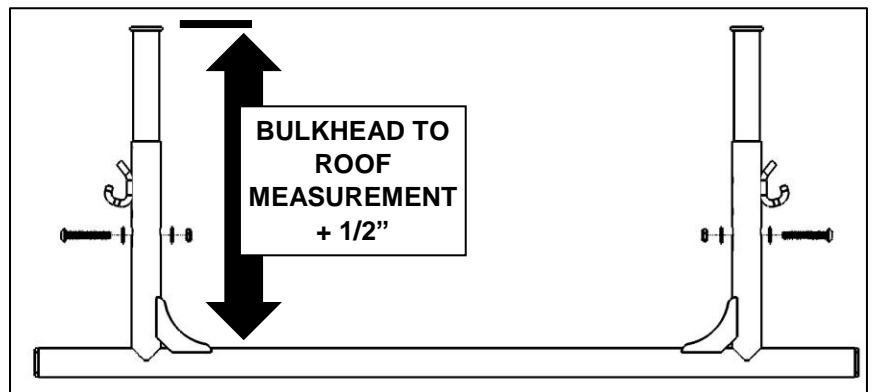

Step 5 – Join Side Channels

- Unpack side channels from box. Lay flattened box on ground and use for scratch protection while building rack. Be sure you have correct front and rear side channels paired.

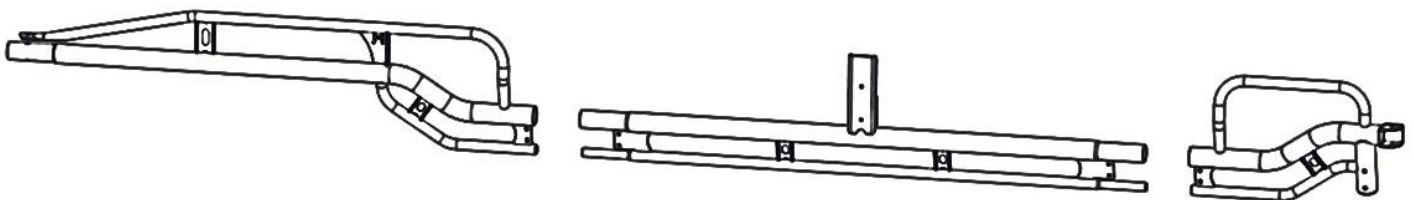

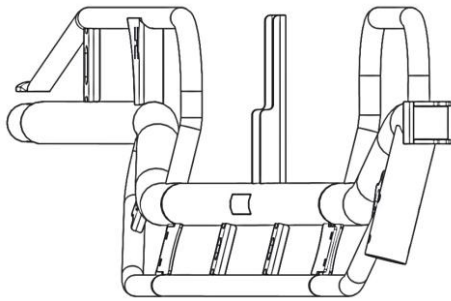

Driver-Side Side Channels

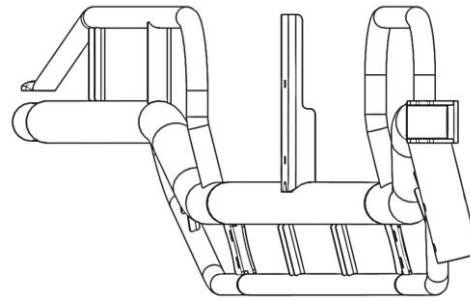

Passenger-Side Side Channels

- Apply sealant to both top and bottom swage joints.
- Insert rear side-channel swaged joints into middle side-channel tubes until holes in splice plates align.
- Insert front side-channel swaged joints into middle side-channel tubes until holes in splice plates align.
- Using 5/16" x 3/4" carriage bolts, 5/16" washers, and 5/16" lock nuts, securely fasten channels together.
- Remove excess sealant.
- Repeat process for opposite side.

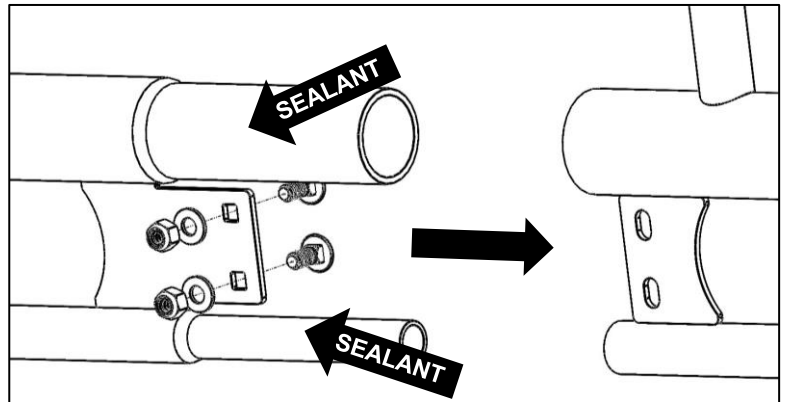

Step 6 – Attach Wind Deflector

- Position wind deflector on front U-tube.
- Insert wind deflector straps into slots on rear of wind deflector.
- Using #10 x 3/4" screws and #10 washers, bolt through top of wind deflector into press-in nuts on wind deflector straps.
- Tighten.

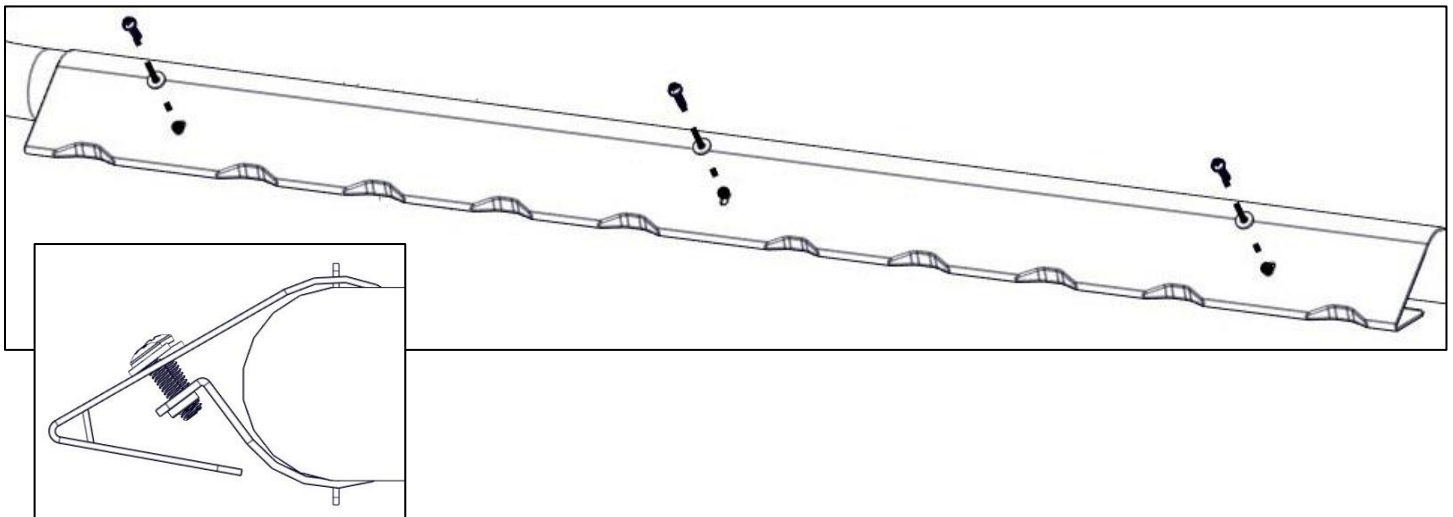
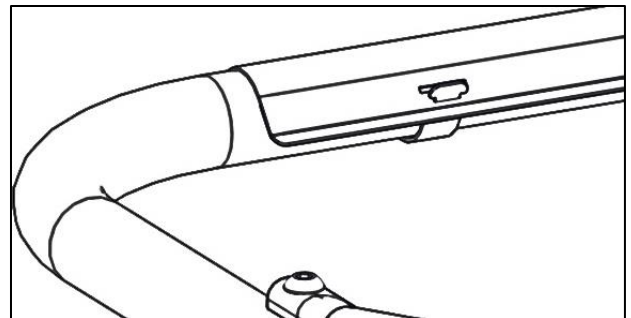

Step 7 – Attach Front Tube

- Apply sealant to front side-channel swaged joint.
- Insert front side-channel swaged joint into front tube until bolt holes in tube and side-channel align.
- Apply sealant around top hole.
- Loosely fasten front tube to side channel using 1/2" x 3" partially threaded button head screw, 1/2" washer, and 1/2" lock nut.
- Remove excess sealant.
- Repeat process on opposite side.

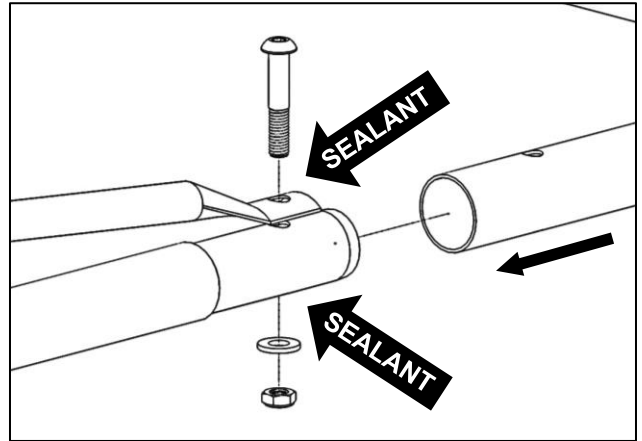

Step 8 – Attach Center Crossbar

- Using two 3/8" x 1" carriage bolts, 3/8" flat washers, and 3/5" thin lock nuts, attach the center crossbar to the crossbar support.
- Repeat on opposite side of rack.
- Loosely tighten on both sides.

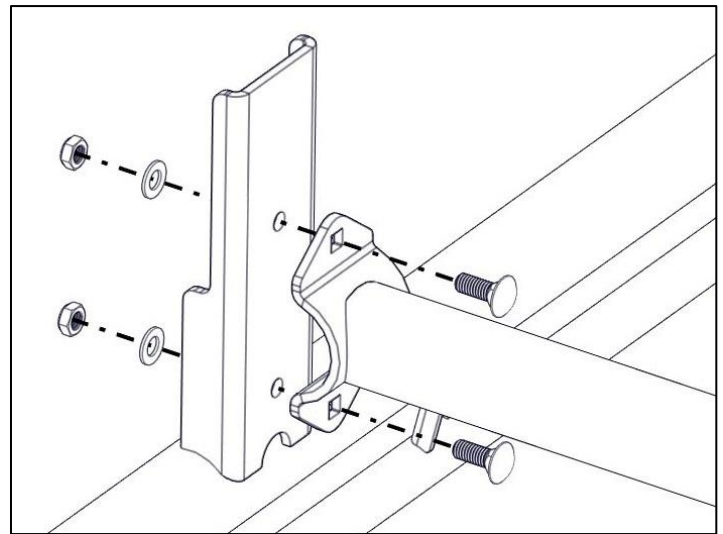

Step 9 – Attach Rear Take-out Bar

NOTE: The rear take-out bar can be installed to open in either direction. One end is bolted and the other side is secured with a removable pin. The bolted side of rear take-out bar can be identified by pressed-in bearings.

- On the side to be bolted, slide end with press-in bearings onto rear side-channel receiver. Be sure the lock-down hole in the end is towards the front of the vehicle.
- Using 3/8" x 2-1/2" hex head, two 3/8" washers, and a 3/8" lock nut, bolt the rear take-out bar to the receiver. On opposite side, insert 3/8" lock pin.

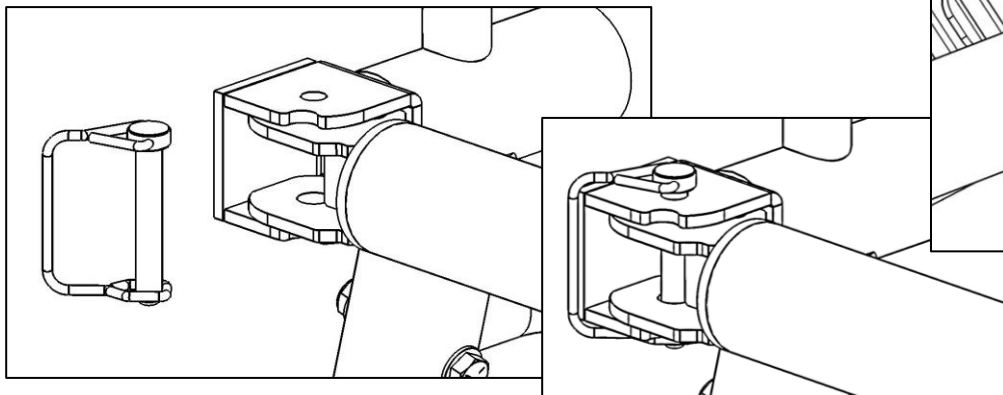
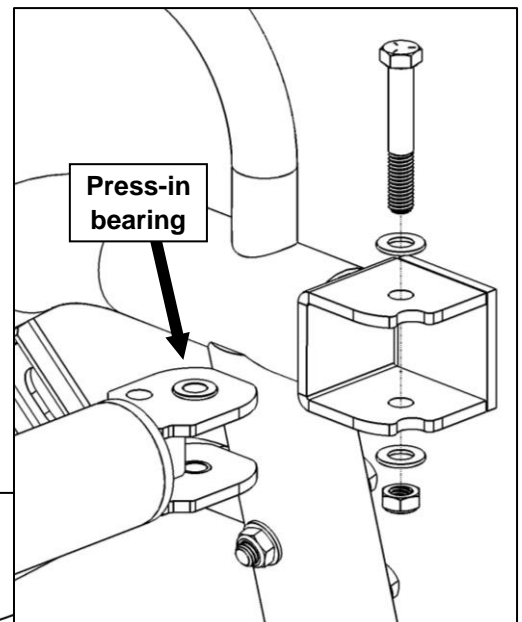

Step 10 – Attach Rear Legs

- Flip rack upside down.
- Apply sealant to swaged joint on one leg and around holes in leg cup.
- Orient leg correctly with side channel, with rope hook away from center of rack, and then insert leg into leg cup until holes in leg and leg cup align.
- Loosely fasten leg to leg cup using, one 3/8" x 2-1/2" hex head bolt, two 3/8" washers, and one 3/8" lock nut. **Be sure to apply sealant around bolt between each washer and leg cup as you assemble.**
- Remove excess sealant.
- Repeat process on opposite side.
- Tighten hex head bolt until legs are solidly fastened (up to 35 ft-lb.)

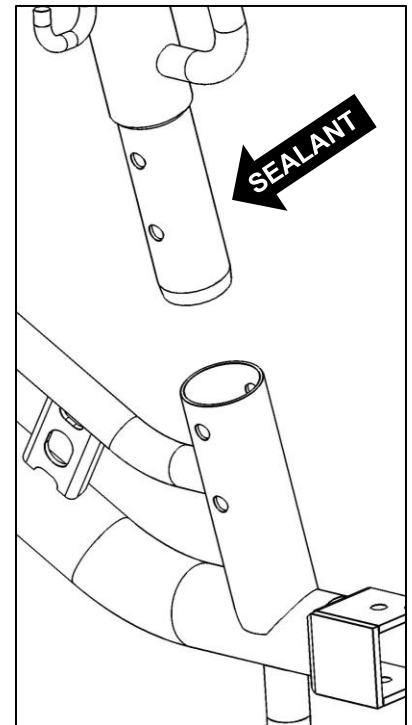
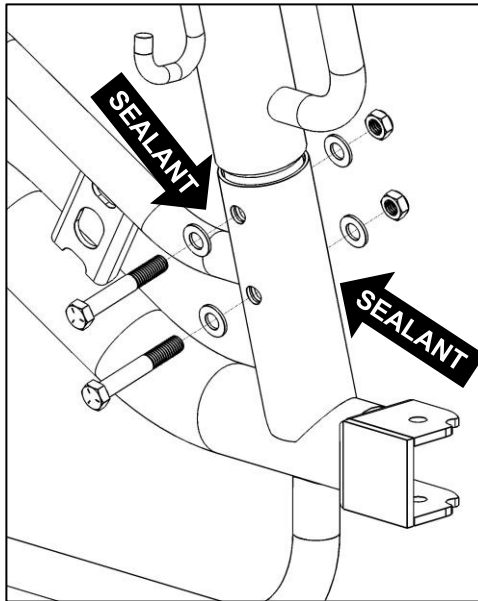

Step 11 – Attach Front Legs

- Place strapping bracket against the 2" diameter tube on the side channel.
- Position the rear side of each strapping bracket **2-3/4" less** than the distance measured earlier from the absolute rear of rack.

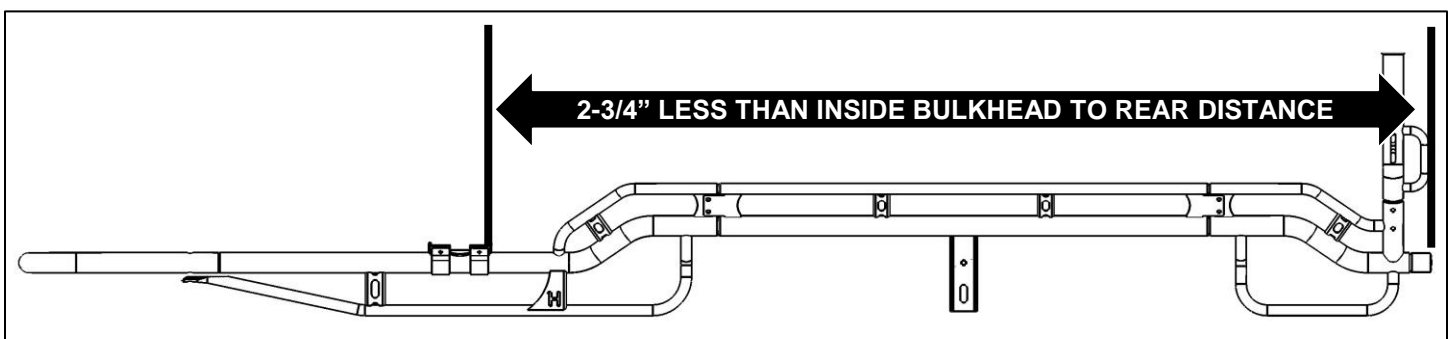

- Hook two of the side channel clamps into the slots on the head of the strapping bracket.
- Using a 5/16" x 1" hex bolt, a 5/16" lock washer, and 5/16" flanged lock nut, LOOSELY fasten each clamp to the head of the leg.

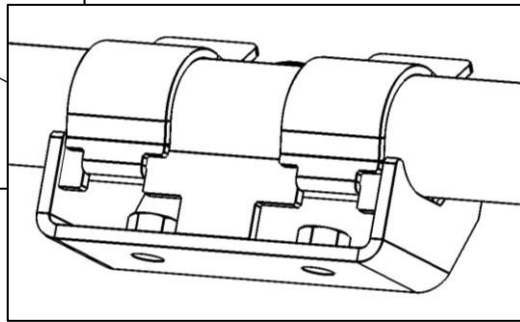
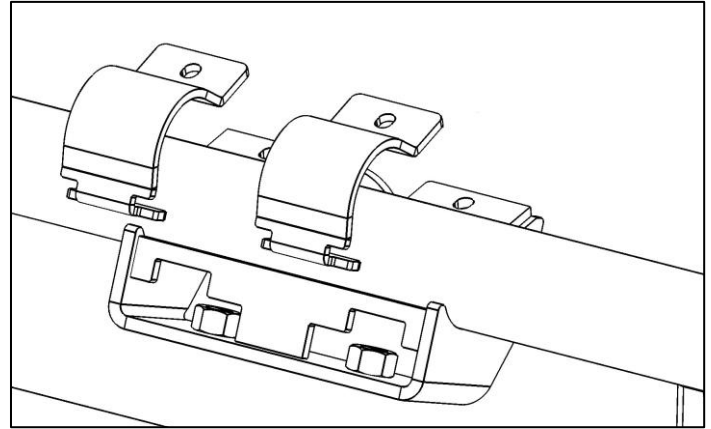
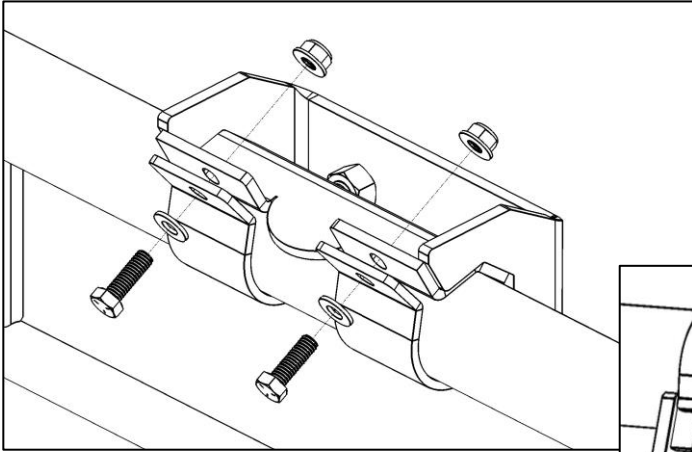

- Using 1/2" x 1-1/4" hex head screws, 1/2" lock washers, 1/2" flat washers, secure the front leg assembly to the crossbar strapping bracket.
- Repeat for opposite side.
- Snug tighten but allow for movement.

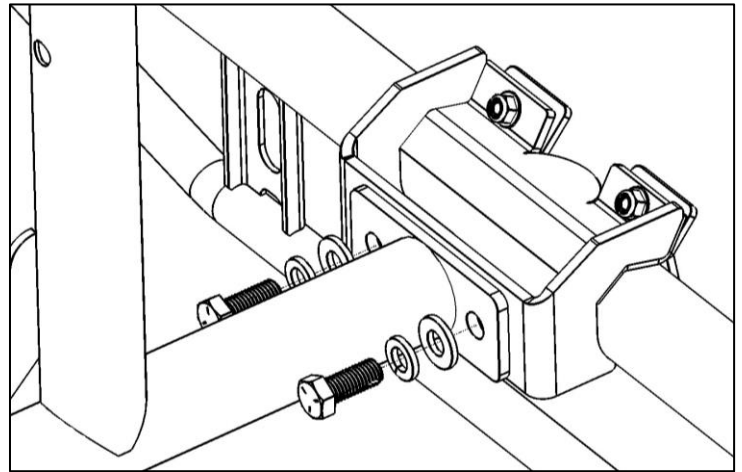

Step 12 – Install Foot to Rack

Depending on the model of service body the rack is installed on, it may be necessary to install the rear feet pointed inwards instead of the typical rear foot installation pointed outwards.

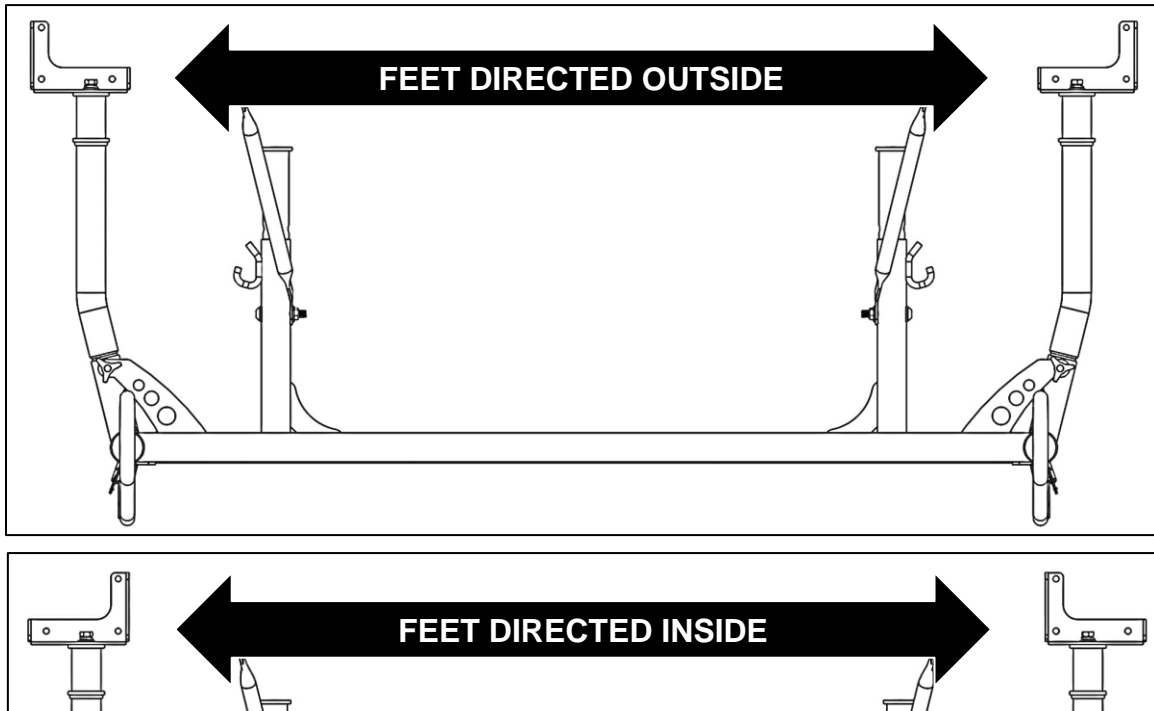

Also depending on the model of service body the rack is installed on, it may be necessary to install the 3" leg extension prior to installing the rear feet. If the service body has flip-open top lid door, then the extension is most likely necessary.

If **NOT** installing the 3" extension:

- Using one 1/2" x 1-1/4" hex head bolt, one 1/2" lock washer, and one 1/2" washer, loosely install the rear foot to the rear leg.
- Snug tighten but allow for movement.
- Repeat on the opposite side.

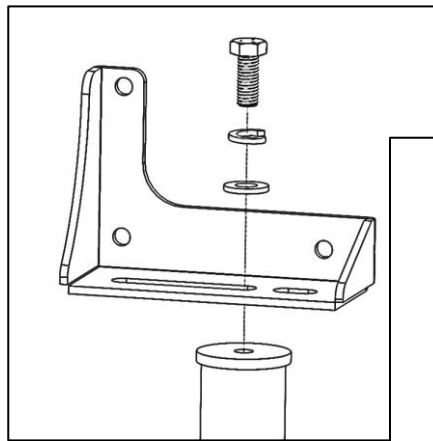

If installing using the 3" leg extensions (or optional 9" leg extensions):

- Using one 1/2" x 4-1/2" hex head bolt, one 1/2" lock washer, and one 1/2" washer, loosely install the rear foot and the 3" extension to the rear leg.
- Snug tighten but allow for movement.
- Repeat on the opposite side.

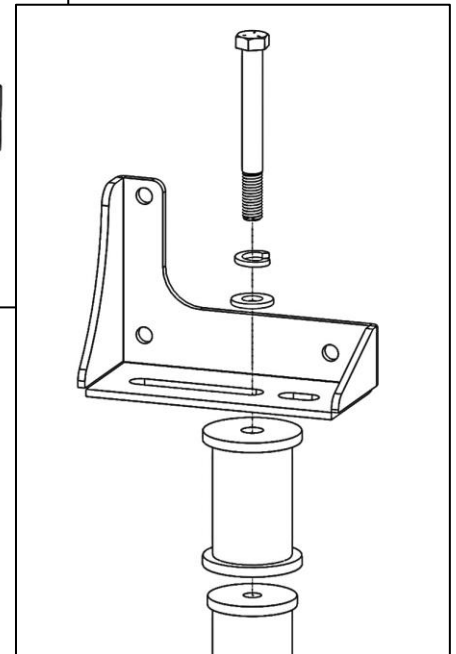

Step 13 – Install Rack onto Service Body

- Lift rack and set legs onto front leg angle mount.
- Loosely fasten front leg angle mount onto legs using two 1/2" x 1-1/4" hex bolts, two 1/2" lock washers, and two 1/2" washers.
- Block, support, or hold rack in place, with side channels level to the service body.
- **Verify clearance above vehicle cab is as recommended on Page 2.** If clearance needs adjustment, remove rack and adjust height of front legs as necessary.

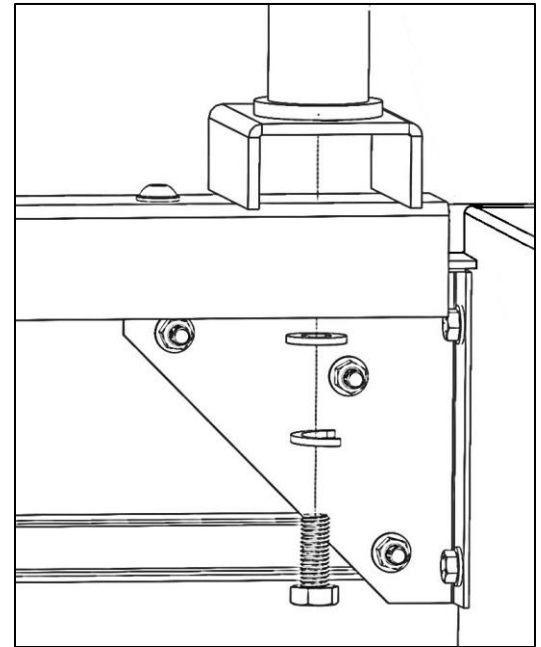

- Position rack with rear feet against rear of service body.
- Position rear feet as close to upper corner and edges of the rear body panel as possible. Be sure clearance is available inside rear panel of service for 3/8" washers and nuts.

NOTE: If feet are reversed, position rear feet as far towards center and as close to vertical interior corner of the rear body panel as possible.

- Mark location of holes in rear feet onto service body.
- Move feet out of the way.
- Using 13/32" drill bit, drill holes in rear of service body where marked.

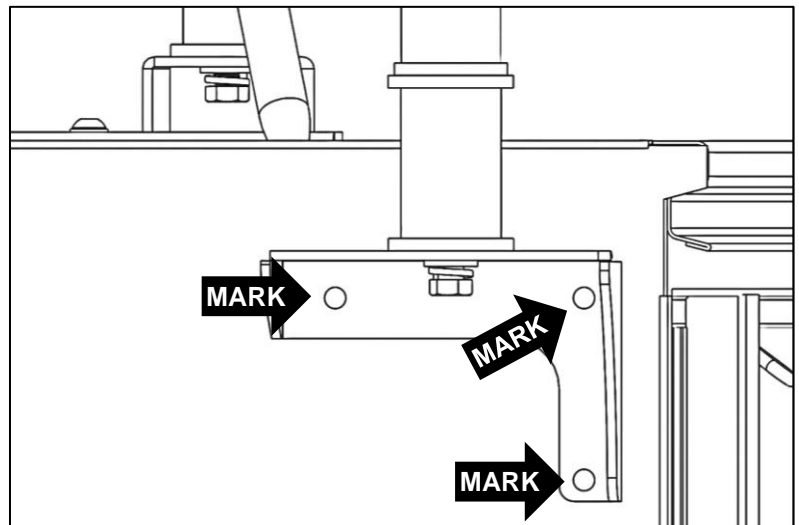

Be sure drilling location is clear of wires, fuel lines, brake lines and other important vehicle functionality items. Use a drill bit stop collar.

- Apply some sealant around each hole drilled into side compartment.
- Using three 3/8" x 1" button head screws, 3/8" washers, and 3/8" lock nuts for each side, securely fasten rear feet to rear of service body.

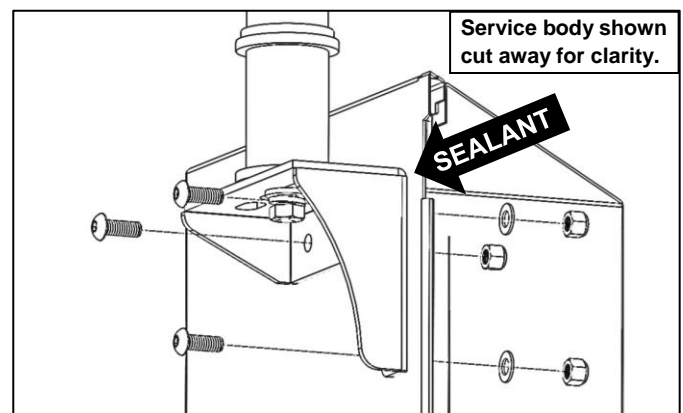

Step 14 – Install Support Arm

- Remove 1/2 lock nut and washer from ONLY one leg on side of rack.
- Position lower end of support arm against inside of service body. If necessary, support arm may need to be moved to opposite side of front leg.
- Position support arm to as close to 45 degrees as possible **while still allowing clearance for 3/8" washer and lock nut inside service body side panel.**
Be sure to allow clearance for flip top door if present.
- Mark location of hole in support arm onto service body side panel.
- Using 13/32" drill bit, drill holes through side panel of service body where marked.



Be sure drilling location is clear of wires, fuel lines, brake lines and other important vehicle functionality items. Use a drill bit stop collar.

- Apply some sealant around the hole.
- Using one 3/8" button head screw, two 3/8" washers, and one 3/8" lock nut, attach support arm to service body side panel.
- Snug tighten but allow for movement.
- Repeat for opposite side.

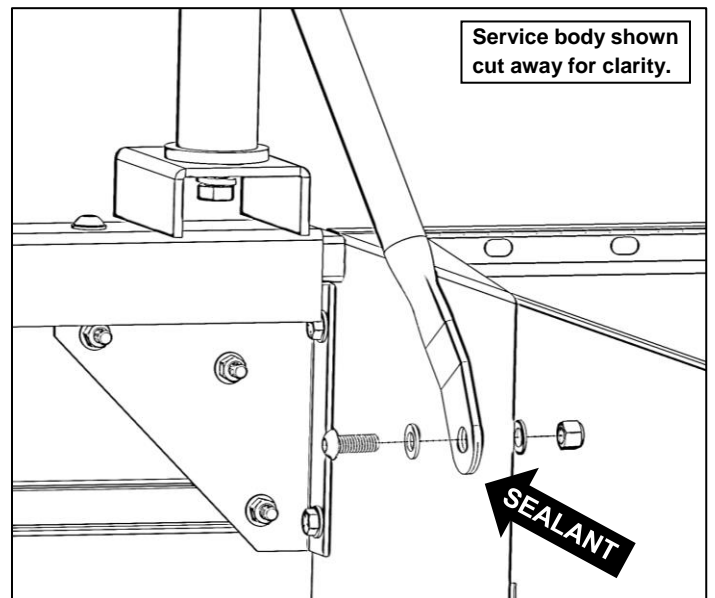
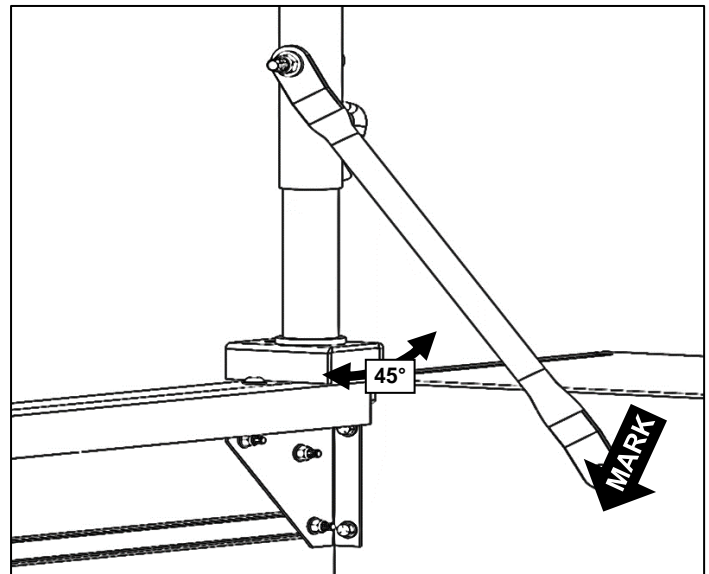

Step 15 – Tighten Hardware

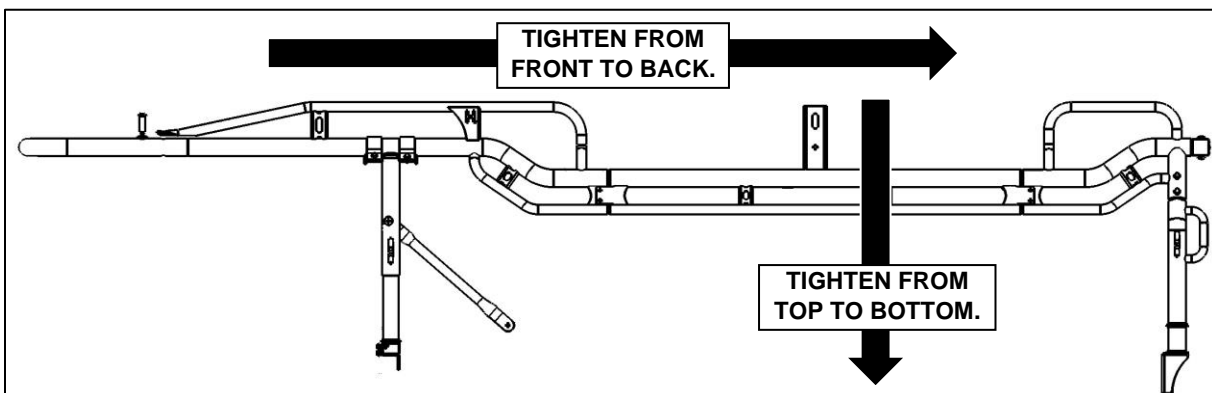

- From front to back, with lock pin installed in rear take-out bar, tighten all side channel and upper front leg screws and bolts.
- Tighten front leg and crossbar hardware.
- Tighten mounting hardware.
- Securely fasten all foot screws and support arm screws.
- Tighten center crossbar.
- Ensure all hardware is tightened.
- Verify rear crossbar lock-pin pulls in and out easily.

Troubleshooting

- Verify rear crossbar lock-pin pulls in and out easily. If necessary, loosen center crossbar hardware, then slide rear crossbar hard left then right about 10 times to get lock-pins to seat properly.

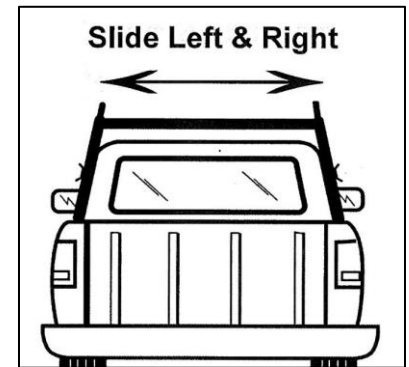

Rear Take-out Bar Position Lock

The rear take-out bar is able to be locked in an open position.

- Remove the pin from the rear take-out bar.
- Open the bar fully.
- Align the hole and notch in take-out bar receiver.
- Insert the pin in the hole and lock the pin in the lock position.

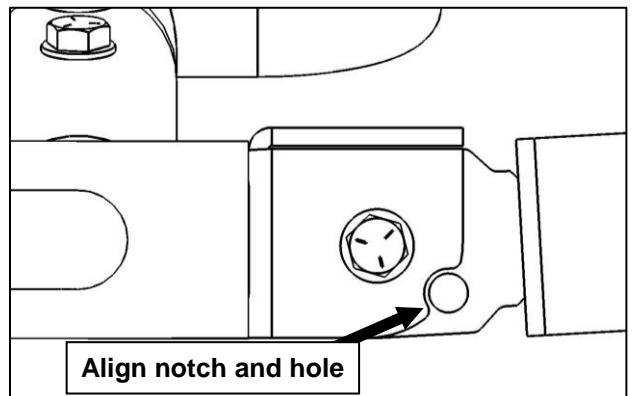

DO NOT DRIVE VEHICLE WITH REAR TAKE-OUT BAR IN OPEN POSITION!

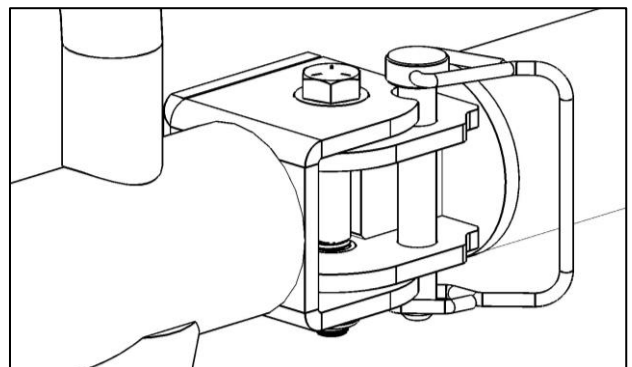

Adjust Wind Deflector

The best angle for the wind deflector will depend on the vehicle the rack is installed on. Small angle adjustments can make a big difference. The image shown is approximately the best angle to start with.

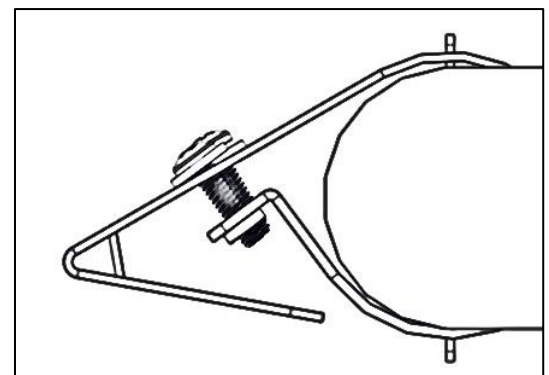

Install Extra Crossbar

- Using 3/8" x 1" carriage bolts, 3/8" washers, and 3/8" thin lock nuts, bolt each end of extra crossbar to bottom tube of side channels.
- Tighten.
- Using 3/8" set screw, tighten telescoping crossbars.

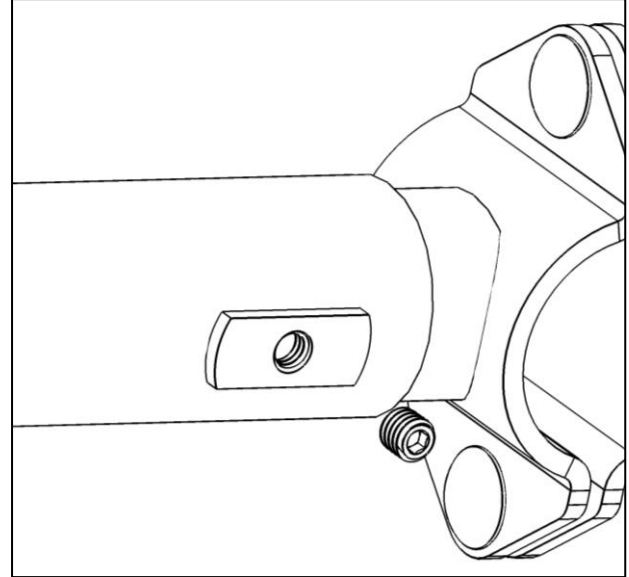
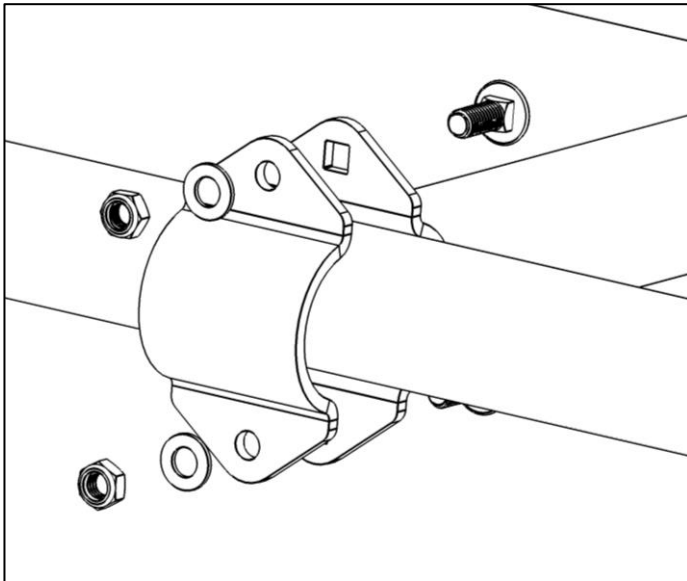

GO BACK AND TIGHTEN ALL HARDWARE. If cordless impact wrench was used to assemble, tighten all hardware using wrenches and sockets.

INSTALLATION AND ASSEMBLY ARE COMPLETE.