



**WE PUT EVERYTHING WITHIN REACH.**

---

# Installation Guide

---

## 406TLF

---

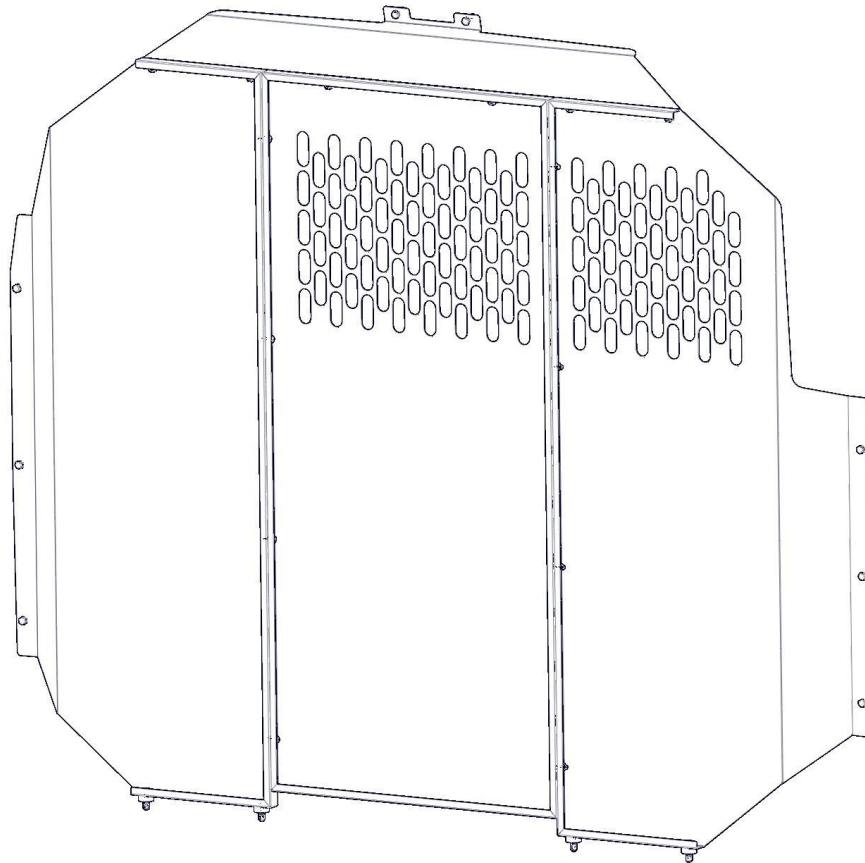

---

Kargo Master  
Rancho Cordova, CA 95742  
800-343-7486  
CustomerService@KargoMaster.com

---

DATE: \_\_\_\_\_

**\*PLEASE READ ALL INSTRUCTIONS AND WARNINGS PRIOR TO ASSEMBLING,  
INSTALLING, AND USING THIS PRODUCT\***

**Warning**



Always check for wires, fuel tanks and lines, brake lines, and other important vehicle functionality items prior to drilling and installing all products.

**Tools Needed**

7/16" Socket and Wrench	3/8" Socket and Wrench
25/64" Drill Bit	

**Table of Contents**

Parts List ..... 2

Hardware List ..... 3

Assembly

Step 1 – Bolt Panels Together ..... 4

Step 2 – Repeat on Drivers Side ..... 5

Step 3 – Top Wing ..... 6

Installation

Step 1 – Prepare to install RivNuts\_ ..... 7

Step 2 – Install RivNuts ..... 8

Step 3 – Bolt Partition ..... 8-9

**Before You Begin**

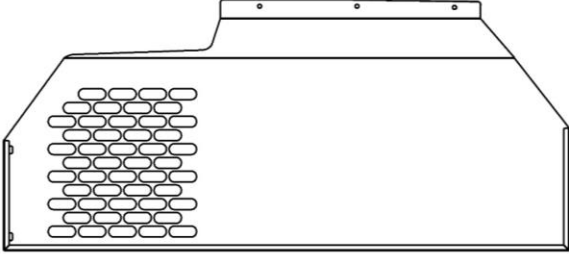
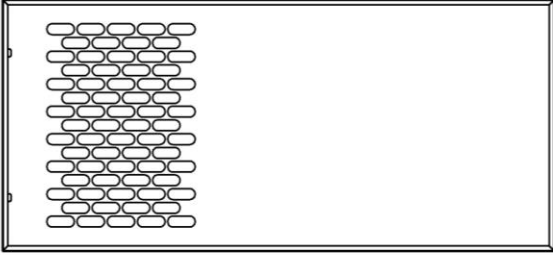
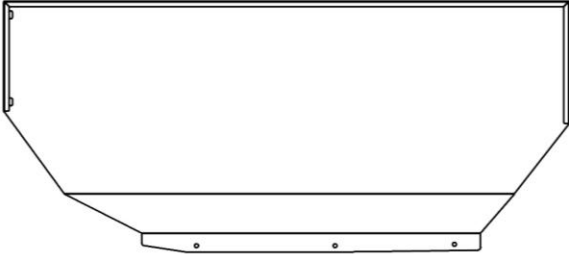
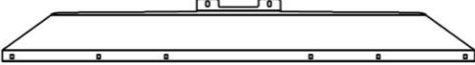

- Read all instructions.
- These instructions are shown using panels with view holes in them. All instructions are the same.

## Parts

ITEM NO.	406TLF-P	PART NUMBER	DESCRIPTION	QTY.
A		406TLF-P1-001	Passenger Side Panel	1
B		406TLF-P1-002	Center Panel	1
C		406TLF-10-003	Driver Side Panel	1
D		406TLF-10-004	Top Wing	1
		18-406TLF	HARDWARE	1
		INSTRUCTIONS		

\*\*Parts A and B are shown with view holes. In some situations these holes will not be there\*\*

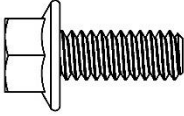
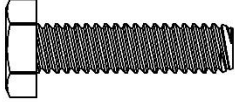
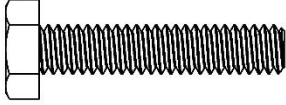
## Hardware

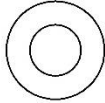
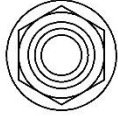
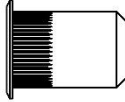
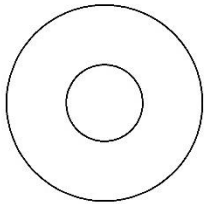
ITEM NO.	TO SCALE	PART NUMBER	DESCRIPTION	QTY.
1		92979A114	.25-20 x .625 Flange HH	14
2		92865A542	.25-20x1.0 HH	8
3		92865A544	.25-20 x 1.25 HH	4
4		.25 Lock Washer	.25 Lock Washer	12
5		.25 flat washer	.25 flat washer	12
6		93298A110	.25-20 Flanged Nyloc Nut	14
7		95105A143	.25-20 ZINC-PLATED STEEL HEAVY-DUTY RIVET NUT	12
8		.375 x 1.0 Nylon Spacer	.375 x 1.0 Nylon Spacer	4

## Assembly

### Step 1 – Bolt Panels Together

- Bolt passenger side panel (A) to middle panel (B) as shown.
- Have the flanges on both panels in same direction.
- Use 1/4" x 5/8" flanged HH bolt (1) and a 1/4" flanged nylock nut (6).
- Repeat 4x total.

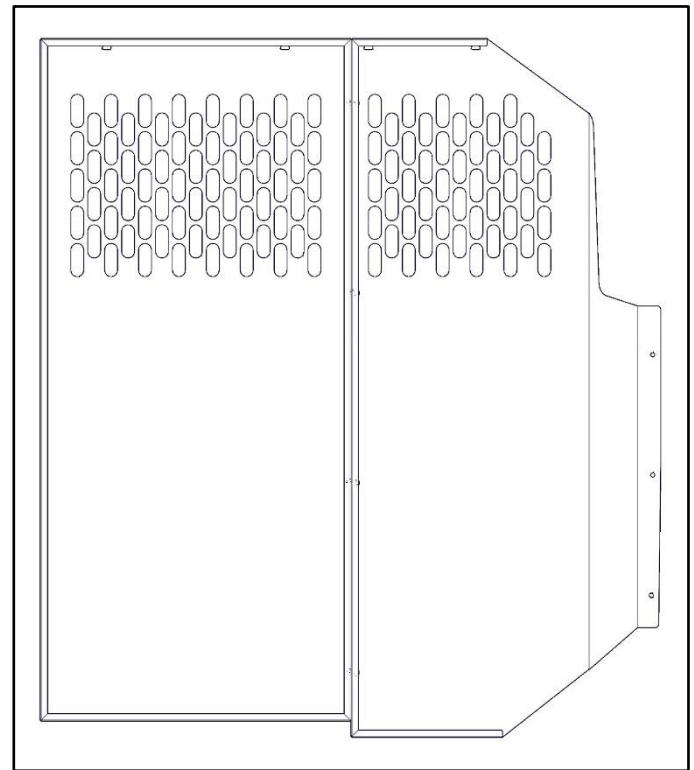
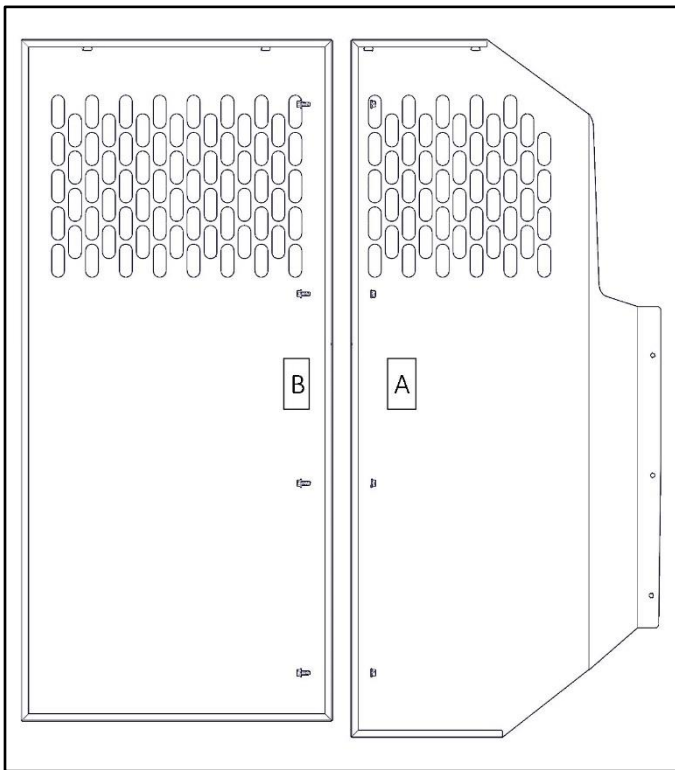
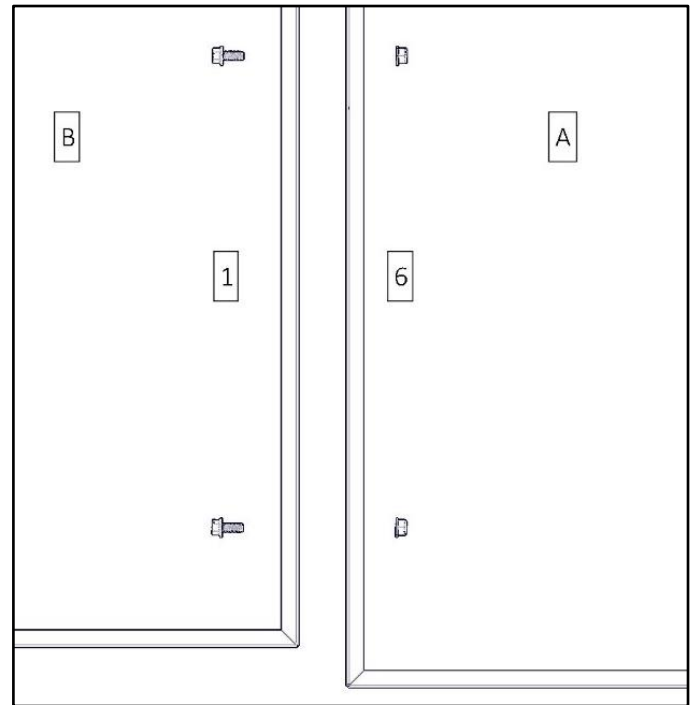

## Step 2 – Repeat on Drivers Side

- Repeat on drivers side using the drivers side panel (C).

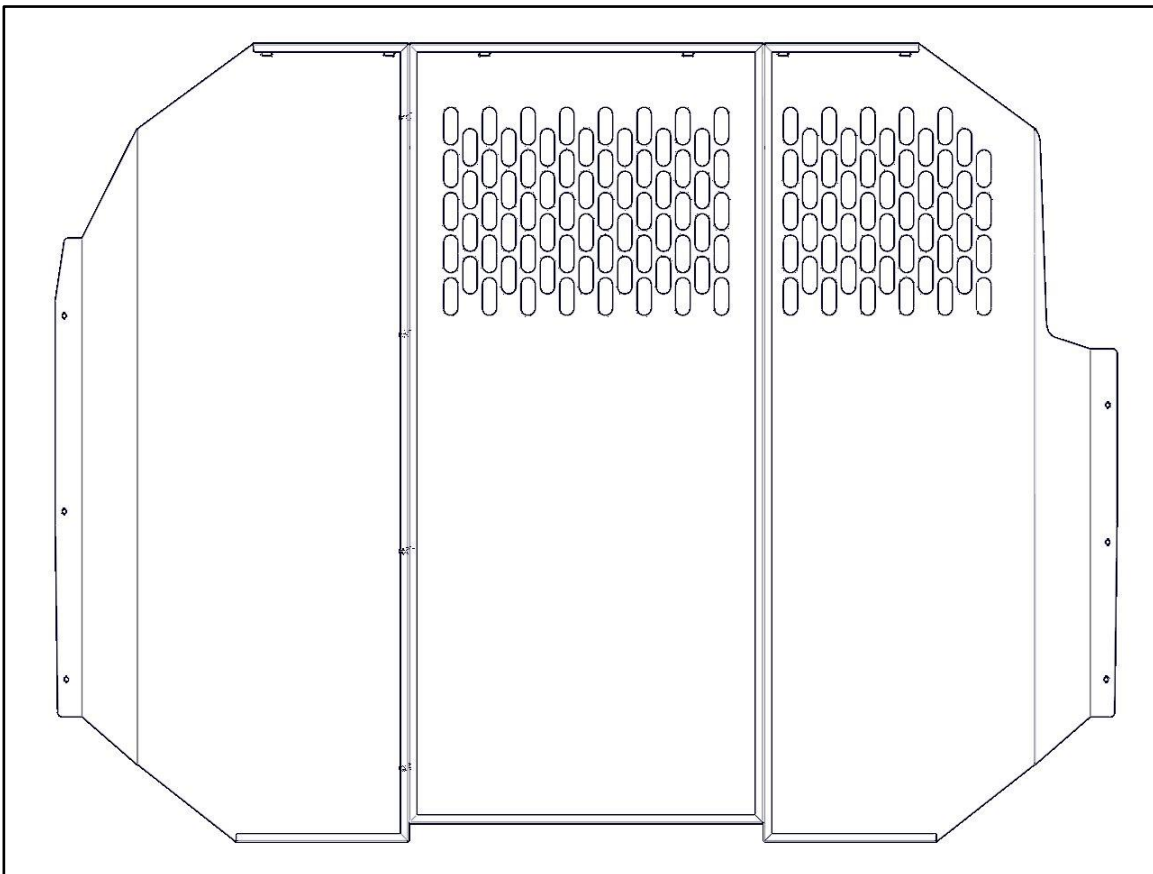
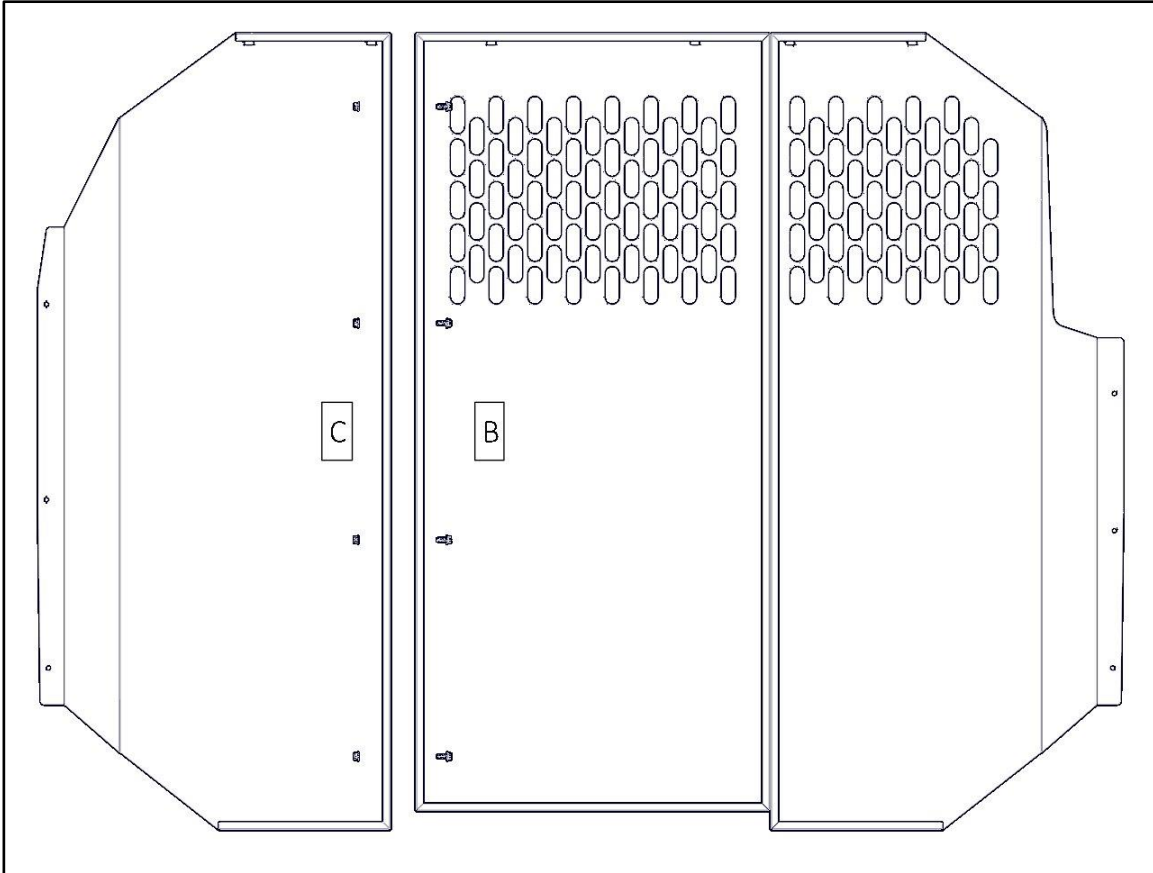

### Step 3 – Top Wing

- Bolt top wing (C) to previously assembled partition as shown.
- Bolt on the flat side of the partition.
- Use 1/4" x 5/8" flanged HH bolt (1) and a 1/4" flanged nylock nut (6).
- Repeat for a total of 6x.

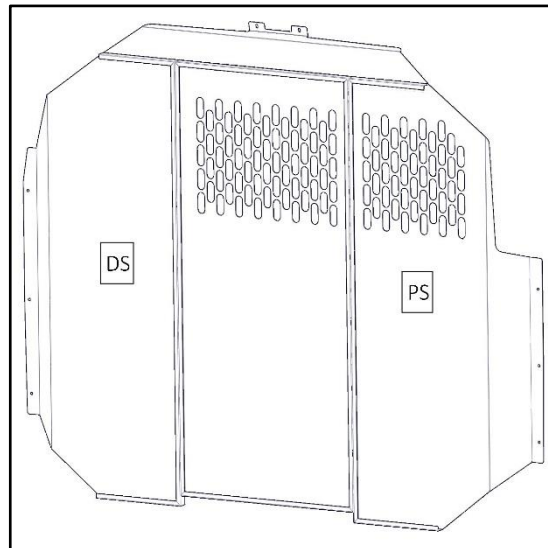
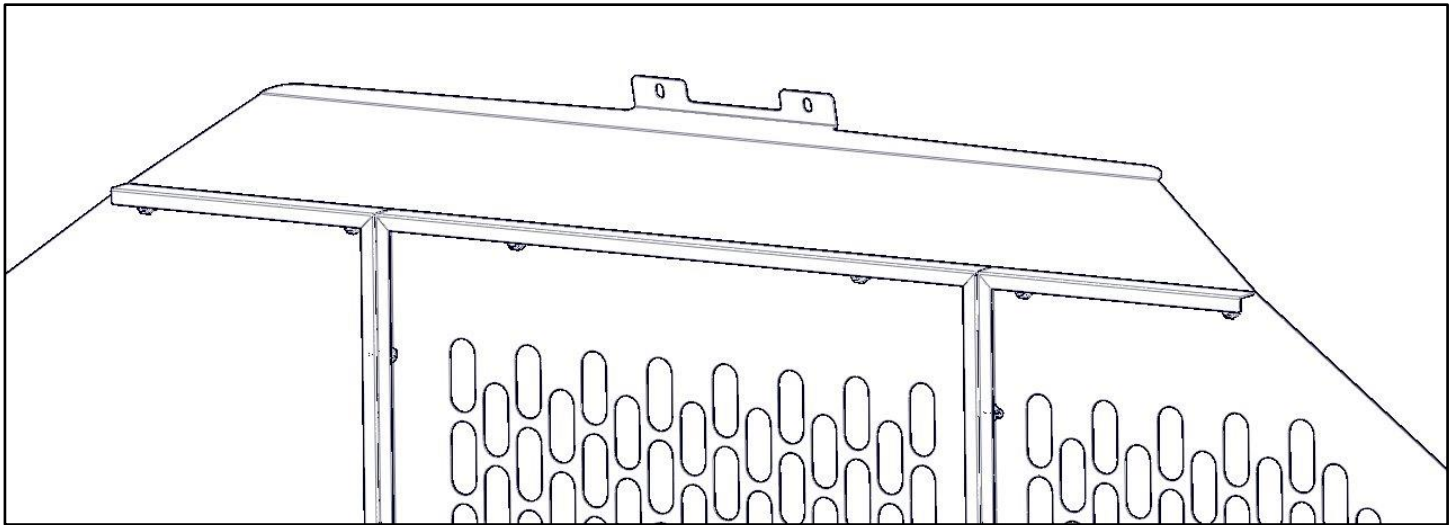
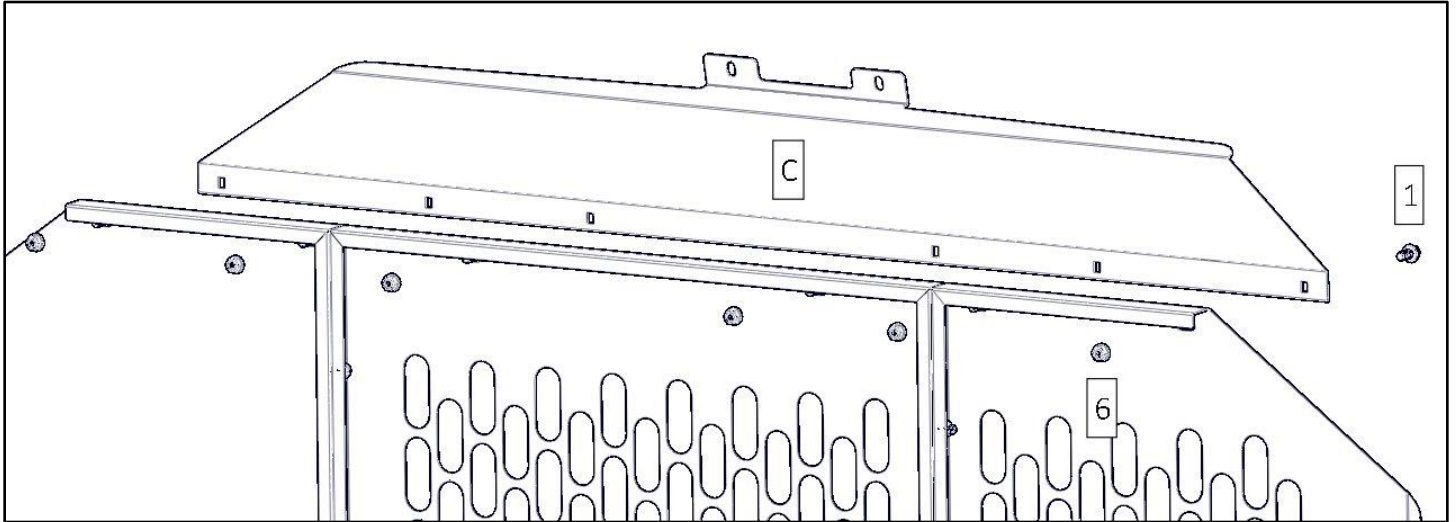



## INSTALLATION

### Step 1 – Prepare to install RivNuts

- Place assembled partition into van with the wings towards the “B” pillars.
- Press partition firmly against “B” pillars and the headliner across the roof of the van.
- Align and square partition.
- Mark the 3 holes on both side panels (A & C).
- Mark the two holes through the top wing (D) onto the headliner.
- Mark the 3 holes onto the floor through both side panels.
- There should be a total of 15 holes marked.

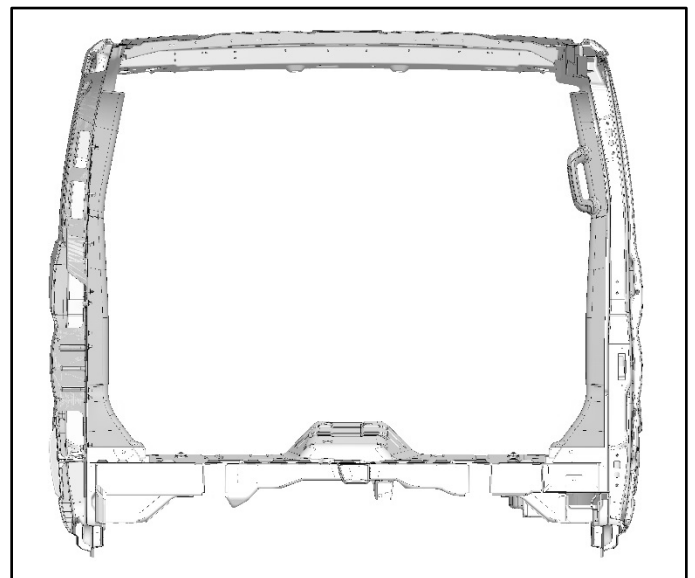
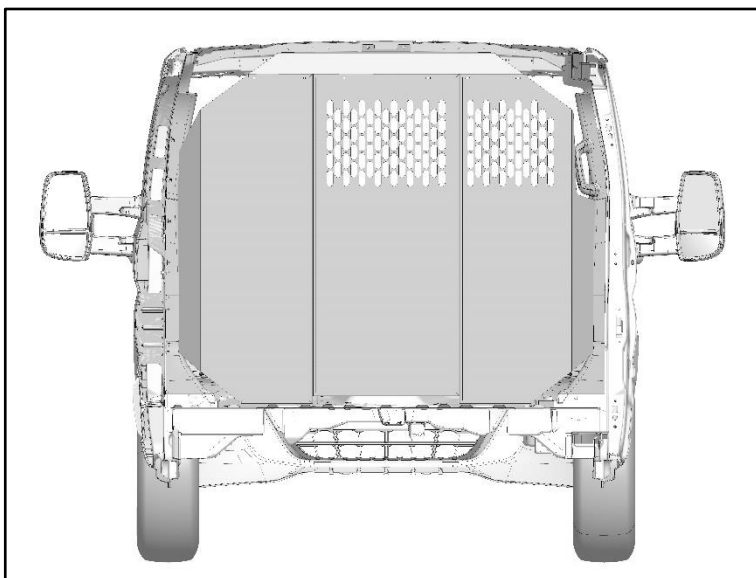
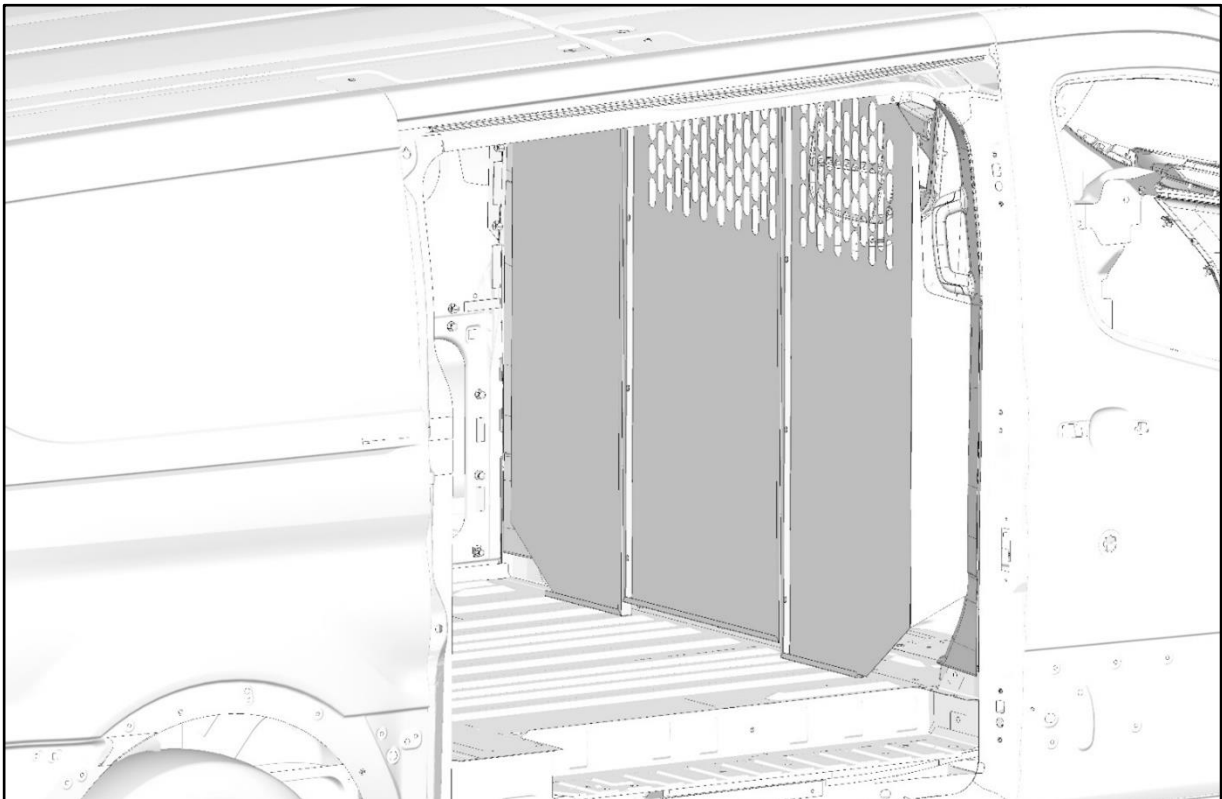



## Step 2 – Install RivNuts

### \*ENSURE SAFETY PRIOR TO DRILLING\*

- Where previously marked, cut the plastic along the “B” pillars to expose the metal behind the plastic. Be sure to keep the marked locations. Drill these marked locations using a 25/64” drill bit.
- Along the floor, choose the two best marked locations on each panel and drill using a 25/64” drill bit.
- Along the support in the roof, cut headliner back to expose metal. Drill the two marked locations using a 25/64” drill bit.
- Install RivNuts where previously drilled.

## Step 3 – Bolt Partition

- Place assembled partition back into van.
- Along the “B” pillars, bolt partition into previously installed RivNuts using a 1/4" x 1" HH (2), a 1/4" split lock washer (4) and a 1/4" flat washer (5).

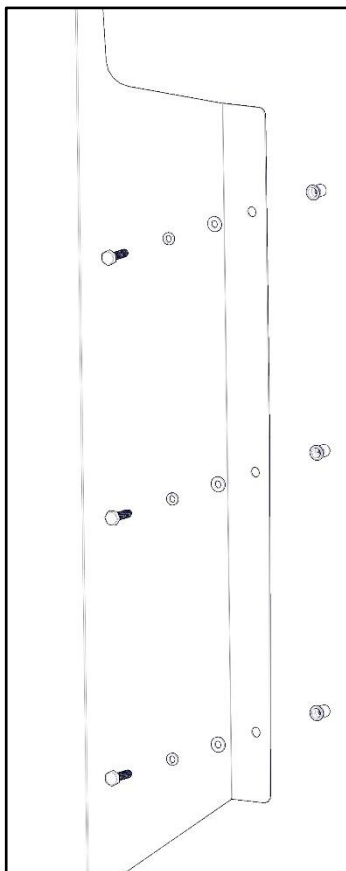

Passenger Side EXP

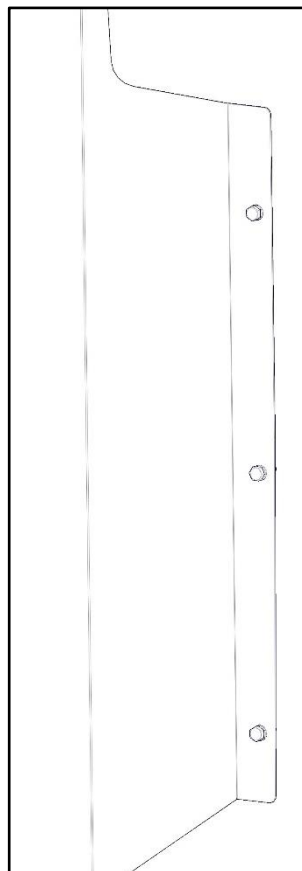

Passenger Side

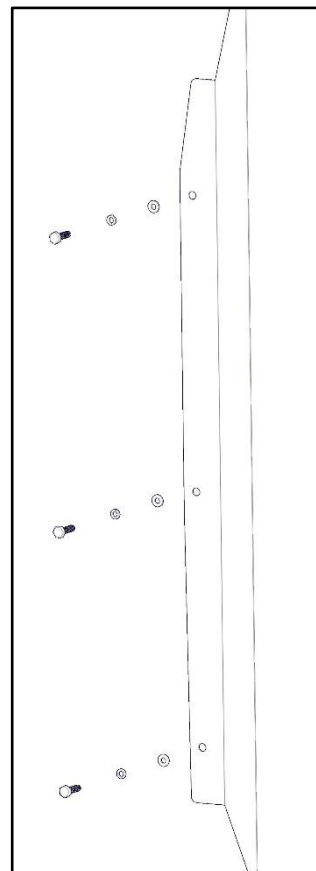

Driver Side EXP

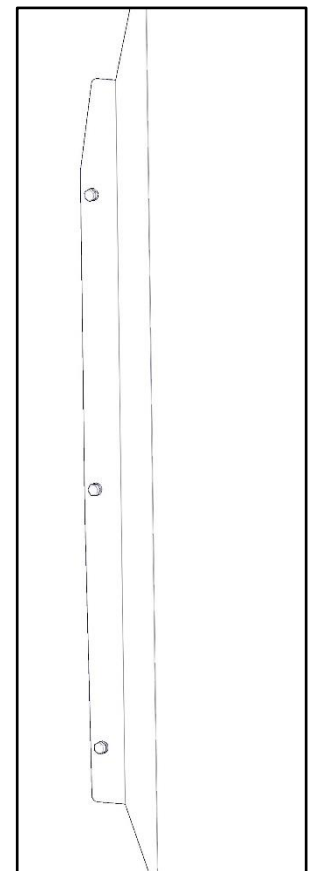

Driver Side

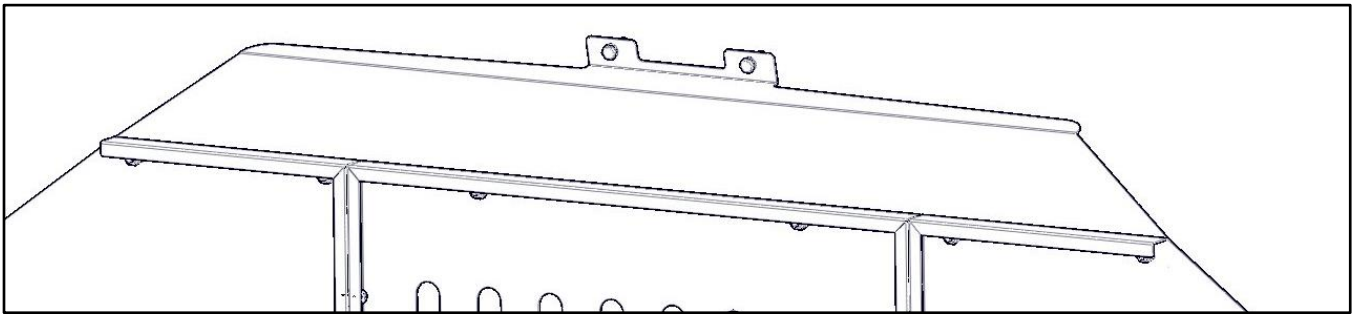
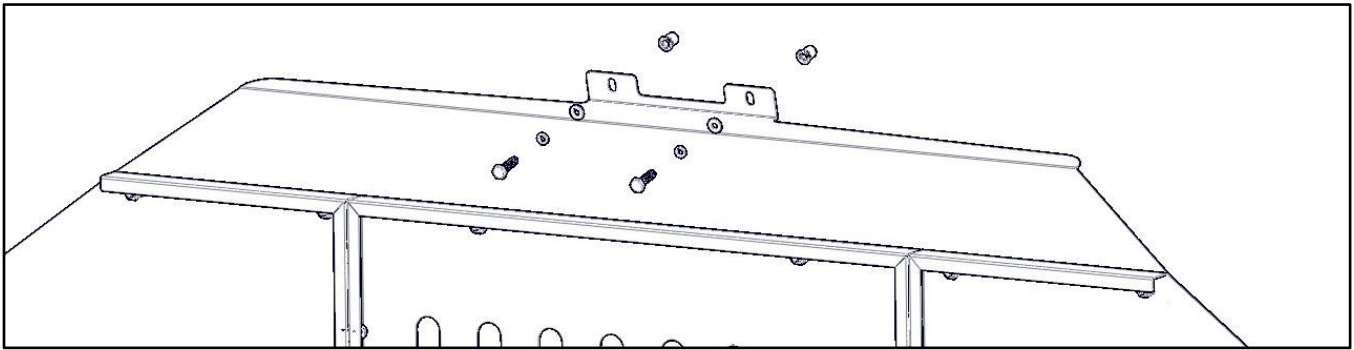

- Along the top wing, bolt partition into previously installed RivNuts using a 1/4" x 1" HH (2), a 1/4" split lock washer (4) and a 1/4" flat washer (5).

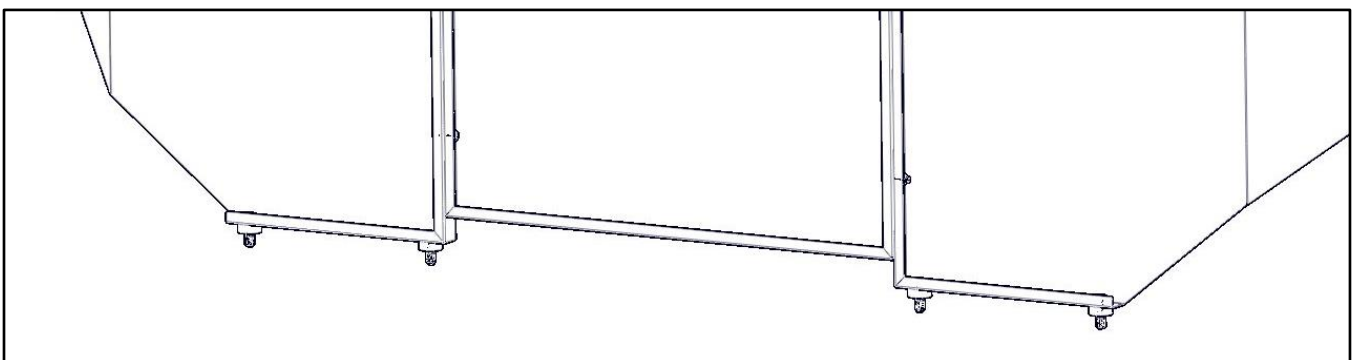
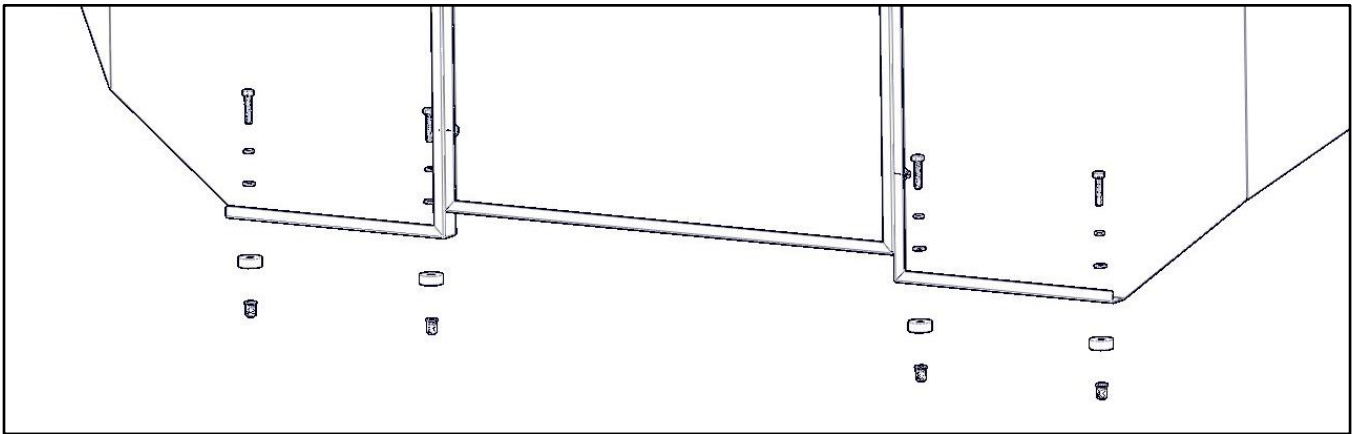

- Along the floor, bolt into RivNuts using 1/4" x 1.25" HH (3), a 1/4" split lock washer (4) and a 1/4" flat washer (5). Place a 3/8" spacer (8) where needed.

**\*\*TIGHTEN ALL BOLTS. YOUR INSTALLATION IS NOW COMPLETE\*\***